



647382 EN (01/12/2018)

260 TJ
280 TJ

OPERATOR'S MANUAL
(ORIGINAL INSTRUCTIONS)

IMPORTANT

Carefully read and understand this instruction manual before using the lifting platform.

*It contains all information relating to operation, handling and lifting platform equipment,
as well as important recommendations to be followed.*

*This document also contains precautions for use, as well as information on the servicing and routine maintenance required
to ensure the lifting platform's continued safety of use and reliability.*

WHENEVER YOU SEE THIS SYMBOL IT MEANS:



WARNING ! BE CAREFUL ! YOUR SAFETY OR THE SAFETY OF THE LIFTING PLATFORM IS AT RISK.

- This manual has been produced on the basis of the equipment list and the technical characteristics given at the time of its design.
- The level of equipment of the lifting platform depends on the options chosen and the country of sale.
- According to the lifting platform options and the date of sale, certain items of equipment/functions described herein may not be available.
- Descriptions and figures are non binding.
- MANITOU reserves the right to change its models and their equipment without being required to update this manual.
- The MANITOU network, consisting exclusively of qualified professionals, is at your disposal to answer all your questions.
- This manual is an integral part of the lifting platform.
- It is to be kept in its storage space at all times for ease of reference.
- Hand this manual to the new owner if the lifting platform is resold.

1st ISSUE	27/02/2012	
UPDATED	14/06/2012	1-20 ; 1-21 2-4 ; 2-6 ; 2-8 ; 2-12 ; 2-13 ; 2-14 ; 2-17 3-6 ; 3-9 4-
	13/02/2015	Update EN280
	20/09/2017	1-20 ; 1-22 <-> 1-24 ; 2-3 ; 2-8 ; 2-11 ; 2-12 ; 2-18 ; 2-21 ; 2-26 ; 2-27 ; 2-29 <-> 2-31 ; 2-35 ; 2-37 ; 2-38 ; 2-40 ; 2-45 <-> 2-47 ; 2-49 ; 2-51 ; 2-55 3-3 ; 3-6 ; 3-7 ; 3-9 ; 3-10 <-> 3-21 ; 3-23 <-> 3-25 ; 3-28 <-> 3-34 ; 3-36 4-1 <-> 4-12
	01/12/2018	1-1 <-> 1-16 2-1 <-> 2-76 3-1 <-> 3-60 4-6 ; 4-11

Manitou BF S.A Limited liability company with a Board of Directors.
 Head office: 430, Rue de l'Aubinière - 44150 Ancenis - FRANCE
 Share capital: 39,548,949 euros
 857 802 508 RCS Nantes.
 Tel: +33 (0)2 40 09 10 11
 www.manitou.com

This manual is for information purposes only. Any reproduction, copy, representation, recording, transfer, distribution, or other, in part or in whole, in any format is prohibited. The plans, designs, views, commentaries and instructions, even the document organization that are found in this document, are the intellectual property of MANITOU BF. Any violation of the aforementioned may lead to civil and criminal prosecution. The logos as well as the visual identity of the company are the property of MANITOU BF and may not be used without express and formal authorization. All rights are reserved.

1 - OPERATING AND SAFETY INSTRUCTIONS

2 - DESCRIPTION

3 - MAINTENANCE

4 - ACCESSORIES

260 TJ



280 TJ



1 - OPERATING AND SAFETY INSTRUCTIONS

1 - OPERATING AND SAFETY INSTRUCTIONS

INSTRUCTIONS TO THE COMPANY MANAGER

1-4

THE SITE	1-4
THE OPERATOR	1-4
PLATFORM	1-4
A – SUITABILITY OF THE PLATFORM FOR THE TASK	1-4
B - ADAPTING THE PLATFORM TO USUAL ENVIRONMENTAL CONDITIONS	1-4
C - MODIFYING THE PLATFORM	1-5
INSTRUCTIONS	1-5
MAINTENANCE	1-5

INSTRUCTIONS FOR THE OPERATOR

1-6

INTRODUCTION	1-6
GENERAL INSTRUCTIONS	1-6
A - INSTRUCTION MANUAL	1-6
B - AUTHORISATION FOR USE IN FRANCE	1-6
C - MAINTENANCE	1-6
D - MODIFYING THE PLATFORM	1-7
E - DIESEL PLATFORM AXLES	1-7
F - SAFETY DEVICES.	1-7
OPERATING INSTRUCTIONS	1-7
A - BEFORE STARTING-UP THE PLATFORM.	1-7
B - DRIVER'S OPERATING INSTRUCTIONS	1-7
C - ENVIRONMENT	1-8
D - VISIBILITY	1-9
E - STARTING-UP THE ENGINE-POWERED PLATFORM.	1-9
E - STARTING UP THE ELECTRIC-POWERED PLATFORM.	1-9
F - OPERATING THE PLATFORM	1-10
G - STOPPING THE PLATFORM	1-10
INSTRUCTIONS FOR WELDING AND BLOW TORCH WORK ON AN EXTERNAL STRUCTURE	1-11
A - WITH AN ELECTRICAL WELDING SET	1-11
B - WITH A BLOW TORCH	1-11

PLATFORM MAINTENANCE INSTRUCTIONS

1-12

GENERAL INSTRUCTIONS	1-12
MAINTENANCE	1-12
LUBRICANT AND FUEL LEVELS	1-12
BATTERY ELECTROLYTE LEVEL (ELECTRIC PLATFORM)	1-12
HYDRAULICS	1-12
ELECTRICITY	1-13
TILT SENSOR	1-13
WELDING ON THE ACCESS PLATFORM	1-13
WASHING THE PLATFORM	1-13

IF THE PLATFORM IS NOT TO BE USED FOR A LONG TIME **1-14**

INTRODUCTION	1-14
PREPARING THE PLATFORM	1-14
PROTECTING THE ENGINE (DIESEL PLATFORM)	1-14
BATTERY CHARGING (ELECTRIC PLATFORM)	1-14
PROTECTING THE PLATFORM	1-14
BRINGING THE PLATFORM BACK INTO SERVICE	1-14

DISPOSING OF THE PLATFORM **1-15**

RECYCLING OF MATERIALS	1-15
METALS	1-15
PLASTICS	1-15
RUBBER	1-15
GLASS	1-15
ENVIRONMENTAL PROTECTION	1-15
WORN OR DAMAGED PARTS	1-15
USED OIL	1-15
USED BATTERIES.	1-15

INSTRUCTIONS TO THE COMPANY MANAGER

THE SITE

Proper management of the personnel lifting platform's area of travel will reduce the risk of accidents:

- Ground not unnecessarily uneven or obstructed.
- No excessive slopes.
- Pedestrian traffic controlled, etc.

THE OPERATOR

- Only qualified, authorised personnel can use the platform. This authorisation is given in writing by the appropriate person in the establishment where the platform is to be used and must be carried permanently by the operator.

⚠ IMPORTANT ⚠

On the basis of experience, there are a number of possible situations in which operating the platform is contra-indicated.

Such foreseeable abnormal uses, the main ones being listed below, are strictly forbidden:

- *The foreseeable abnormal behaviour resulting from ordinary negligence, but which does not result from any wish to put the machinery to any improper use.*
 - *The reflex reactions of a person in the event of a malfunction, incident, fault, etc. during operation of the platform.*
 - *Behaviour resulting from application of the "principle of least effort" when performing a task.*
 - *For certain machines, the foreseeable behaviour of such persons as: apprentices, teenagers, handicapped persons, trainees tempted to drive a platform, operators tempted to operate a truck to win a bet, in competition or for their own personal experience.*
- The person in charge of the equipment must take these criteria into account when assessing the suitability of a person to drive.*

⚠ IMPORTANT ⚠

OBTAIN INFORMATION ON:

- *How to behave when there is a fire.*
- *The location of the nearest first aid kit and fire extinguisher.*
- *The emergency telephone numbers for calling (the doctors, ambulance, hospital and fire brigade).*

PLATFORM

A – SUITABILITY OF THE PLATFORM FOR THE TASK

- MANITOU has ensured that this platform is suitable for use under the standard operating conditions defined in this operator's manual, with an **OVERLOAD test coefficient of 1.25** and an **OPERATIONAL test coefficient of 1.1**, as stipulated in harmonised standard **EN 280** for **MPLP** (Mobile Personnel Lifting Platforms). Before putting the platform into operation, the company manager must check that the platform is suitable for the work to be carried out and conduct certain tests (in accordance with current legislation).

B - ADAPTING THE PLATFORM TO USUAL ENVIRONMENTAL CONDITIONS

- In addition to standard equipment mounted on your platform, many options are available, such as: rotating beacon light, working light, etc. Contact your dealer.
- Take into account climatic and atmospheric conditions of the site of utilisation.
 - Protection against frost (↩ 3 - MAINTENANCE: LUBRICANTS AND FUEL).
 - Adaptation of lubricants (ask your dealer for information).
 - Engine filtration (↩ 3 - MAINTENANCE: FILTER CARTRIDGES AND BELTS).

⚠ IMPORTANT ⚠

For operation under average climatic conditions, i.e.: between -15°C and +35°C, lubricants are topped up in the factory.

For operation under more severe climatic conditions, before starting up, it is necessary to drain all the circuits, then ensure correct levels of lubricants using lubricants properly suited to the relevant ambient temperatures. The same applies to coolant.

- Preventing fire risks associated with use in dusty and flammable conditions.
- A platform operating in an area without fire extinguishing equipment must be equipped with an individual extinguisher. Solutions are available, consult your dealer.

⚠ IMPORTANT ⚠

Diesel platforms are designed for outdoor use under normal atmospheric conditions and indoor use in suitably aerated and ventilated premises.

Electric platforms are designed for outdoor use under normal atmospheric conditions and for indoor use.

It is prohibited to use the platform in areas where there is a risk of fire or which are potentially explosive (e.g. refineries, fuel or gas depots, stores of inflammable products, etc.). For use in these areas, specific equipment is available (ask your dealer for information).

C - MODIFYING THE PLATFORM

⚠ IMPORTANT ⚠

It is strictly prohibited to replace platform components with components not approved by Manitou (batteries, wheels, basket, etc.).

⚠ IMPORTANT ⚠

It is strictly forbidden to change the structure and settings of the various components of your platform (hydraulic pressure, calibrating limiters, engine speed, sensors, addition of extra equipment, addition of counterweight, unapproved attachments, alarm systems, etc.) yourself.

In this event, the manufacturer cannot be held responsible.

⚠ IMPORTANT ⚠

Risk of the access platform becoming unstable:

- *Depending on the model, your platform may be supplied with standard wheels or all-terrain wheels. It is PROHIBITED to change from one type of wheel to the other.*
- *ELECTRIC PLATFORM: it is PROHIBITED to replace the batteries with lighter batteries.*

INSTRUCTIONS

- The operator's manual must always be in good condition and kept in the place provided on the platform and in the language used by the operator.
- You must replace the instructions manual, as well as any plates or stickers, if they are no longer legible or are missing or damaged.

MAINTENANCE

⚠ IMPORTANT ⚠

Refer to chapter: PLATFORM MAINTENANCE INSTRUCTIONS.

- Maintenance or repairs other than those detailed in chapter 3 - MAINTENANCE must be carried out by qualified personnel (consult your dealer) and under the necessary safety conditions to maintain the health of the operator and any third party.

⚠ IMPORTANT ⚠

Your platform must be periodically inspected to ensure its continued compliance.

The inspection frequency is defined by the legislation applying in the country in which the platform is used.

- Example for France: The manager in charge of the establishment using an access platform must open and maintain a maintenance log for each machine (order of 2 March 2004).

INSTRUCTIONS FOR THE OPERATOR

INTRODUCTION

⚠ IMPORTANT ⚠

The risk of accident while using, servicing or repairing your platform can be reduced if you follow the safety instructions and preventive measures detailed in these instructions.

Failure to respect the safety and operating instructions, or the instructions for repairing or servicing your platform may lead to serious, even fatal accidents.

- Only the operations and manoeuvres described in this operator's manual must be performed. The manufacturer cannot predict all possible risky situations. Consequently, the safety instructions given in the operator's manual and on the platform itself are not exhaustive.
- As an operator, you must at all times give reasonable consideration to the possible risks to yourself, to others or to the platform itself when you use it.

GENERAL INSTRUCTIONS

A - INSTRUCTION MANUAL

- Carefully read and understand the operator's manual.
- The operator's manual must always be in good condition and kept in the place provided on the platform and in the language used by the operator.
- You must replace the instructions manual, as well as any plates or stickers, if they are no longer legible or are missing or damaged.
- Any operations or manoeuvres not described in the operator's manual are categorically forbidden.
- Follow the safety advice and the instructions on the platform.
- A second operator must be present on the ground as a safety measure when using the platform.
- Familiarise yourself with the platform on the terrain where it will be used.
- The machine must also be used in accordance with good engineering practice.
- Do not use the platform if there is a wind speed of over 45 km/h. The platform's arms must not be subjected to a side force of more than 400 N (40 kg).
- Platforms intended exclusively for indoor use must not be used outside the buildings.

B - AUTHORISATION FOR USE IN FRANCE

(or see current legislation in other countries).

- Only qualified, authorised personnel can use the platform. This authorisation is given in writing by the appropriate person in the establishment where the platform is to be used and must be carried permanently by the operator.
- The operator is not empowered to authorise the driving of the platform by another person.

C - MAINTENANCE

- The operator must carry out the daily maintenance (↩ 3 - MAINTENANCE) before using the platform in his place of work.
- The operator must immediately advise his superior if his platform is not in good working order or does not comply with the safety notice.
- The operator is prohibited from carrying out any repairs or adjustments himself, unless he has been trained for this purpose. He must keep the platform properly cleaned if this is among his responsibilities.
- The operator is responsible for deciding and adjusting the frequency of cleaning needed to prevent the risk of fire ensuing from the build-up of flammable material. The operator should pay special attention to all the areas of the platform where these risk materials are likely to accumulate.
- The operator must ensure that the wheels are appropriate for the type of ground (see the ground contact area of the wheels (↩ 2 - DESCRIPTION: SPECIFICATIONS). Optional solutions are available, consult your dealer.

⚠ IMPORTANT ⚠

Do not use the platform if the wheels are damaged or excessively worn, because this could put your own safety or that of others at risk, or cause damage to the platform itself.

⚠ IMPORTANT ⚠

In the case of electric platforms, the operator must ensure that:

- Safety goggles are always worn when charging the batteries.
 - The batteries are not charged in an explosive environment.
- There is no smoking and no naked flame directed towards the batteries when they are being handled (removal/installation) and when monitoring filling levels.
Do not leave the battery charger connected during a lightning storm.*

D - MODIFYING THE PLATFORM

☞ INSTRUCTIONS TO SITE MANAGER: C - MODIFYING THE PLATFORM.

E - DIESEL PLATFORM AXLES

NON-OSCILLATING AXLE (ACCORDING TO MODEL)

⚠ IMPORTANT ⚠

The chassis is rigid, so the platform can be load bearing on only three wheels.

OSCILLATING AXLE (ACCORDING TO MODEL)

⚠ IMPORTANT ⚠

An oscillating axle enables the platform to have a ground reach on four wheels when in transport position.

When moving in the working position over uneven terrain, the oscillating axle is locked (the frame is stiff) so the platform may be bearing on only three wheels.

F - SAFETY DEVICES

- This machine is fitted with special safety devices that are able to limit its operation as circumstances require (☞ 2 - DESCRIPTION):
 - Overload in the basket.
 - Tilting of the platform beyond the authorised limits.
 - Blocking of the oscillating axle (according to model).
 - Slack or broken telescope cable (according to model).

OPERATING INSTRUCTIONS

A - BEFORE STARTING-UP THE PLATFORM

- Perform the daily maintenance operations (☞ 3 - MAINTENANCE).

B - DRIVER'S OPERATING INSTRUCTIONS

- Whatever their experience, operators are advised to familiarise themselves with the position and operation of the control panels before putting the platform into operation.
- The platform's arms must be fully lowered (down position for scissor platforms) before getting into or out of the basket; always get in and out facing the inside of the basket.
- If the platform is equipped with steps, the basket must be positioned vertically with these before getting in or out.
- Always use both hands and one foot or both feet and one hand to get in and out.
- Ensure that the guard rail and/or the access gate (according to model) is fully in the locked position before operating the platform from the basket.
- MANITOU recommends a safety harness in the operator's size be provided when the platform is in use (for the harness attachment in the basket, ☞ 2 - DESCRIPTION).
- Safety helmets must be worn.
- Wear suitable clothing for driving the platform; do not wear baggy clothes.
- Never operate the platform when hands or feet are wet or soiled with greasy substances.
- Make sure you have the appropriate protective equipment for the job to be done.
- Prolonged exposure to high noise levels may cause hearing problems. It is recommended to wear ear muffs to protect against excessive noise.
- Remain alert at all times when using the platform. Do not listen to the radio or music using headphones or earphones.
- The operator must always be in the normal operator's position. It is prohibited to have arms or legs, or generally any part of the body, protruding from the basket.
- The control units must never in any event be used for any other than their intended purposes (e.g. getting in or out of the basket, portmanteau, etc.).
- The platform must not be fitted with unauthorised attachments that increase the unit's wind load.
- Do not use a ladder or any improvised constructions in the basket to reach greater heights.
- Do not climb on the basket frame to reach greater heights.

C - ENVIRONMENT

- Comply with site safety regulations.
- The platform can be operated from the ground: ensure that you forbid access.
- If you have to use the platform in a dark area or at night, make sure it is equipped with working lights.
- The platforms may not be used as cranes or elevators for the permanent transport of people or materials, nor as jacks or supports.
- Suspending a load under the basket or on any part of the lifting apparatus is strictly forbidden.
- When operating, ensure that there is no one or anything impeding the platform's progress and operation.
- When raising the platform, ensure that no one or anything impedes the platform's operation and do not perform any inappropriate manoeuvres.
- Do not allow anybody to come near the working area of the platform or pass beneath an elevated load. To ensure this, mark out your working area.
- Driving on a longitudinal slope:
 - Adjust the platform speed with the proportional control handle.
- Take into account the platform's dimensions and its load before trying to negotiate a narrow or low passageway.
- Never move onto a loading bridge without having first checked:
 - That it is suitably positioned and made fast.
 - That the unit to which it is connected (wagon, lorry, etc.) will not shift.
 - That this bridge is prescribed for the size and mass of the platform (≤ 2 - DESCRIPTION).
 - That the slope of the bridge is not greater than the platform's maximum authorised slope (≤ 2 - DESCRIPTION).
- Never move onto a foot bridge, floor or freight lift, without being certain that they are prescribed for the mass and size of the platform to be loaded and without having checked that they are in sound working order.
- Be careful in the area of loading bays, trenches, scaffolding, soft ground, manholes, etc.
- Make sure the ground is stable and firm under the wheels and/or stabilisers before lifting the basket. If necessary, add sufficient wedging under the stabilisers. Do not attempt to carry out operations that exceed the platform's capabilities.
- Ensure that any materials loaded onto the platform (pipes, cables, containers, etc.) cannot fall out. Do not pile these materials to the point where it is necessary to step over them.

⚠ IMPORTANT ⚠

If the basket must remain stationary over a structure for a long period, there is a risk that the basket will descend and rest on this structure because of the oil cooling in the cylinders or a minor leak in the cylinder locking system. To eliminate this risk:

- Regularly check the distance between the basket and the structure and re-adjust if necessary.
- If possible use the platform at an oil temperature as close as possible to ambient temperature.

- In the case of work near aerial lines, ensure that the safety distance is sufficient between the working area of the platform and the aerial line.

⚠ IMPORTANT ⚠

You must consult your local electrical agency.

You could be electrocuted or seriously injured if you operate or park the platform too close to power cables.

⚠ IMPORTANT ⚠

If the platform comes into contact with electric wires, press the Emergency Stop button.

Call for help, warn people on the ground not to touch the basket, and ask them to switch off the power supply to the wires or have it switched off.

⚠ IMPORTANT ⚠

It is forbidden to use the platform close to electricity cables. Maintain the specified safe distances.

RATED VOLTAGE (VOLTS)	SAFETY DISTANCE (METRES)
50 < U < 1000	2.30 M
1000 < U < 30000	2.50 M
30,000 < U < 45,000	2.60 M
45,000 < U < 63,000	2.80 M
63,000 < U < 90,000	3.00 M
90,000 < U < 150,000	3.40 M
150,000 < U < 225,000	4.00 M
225,000 < U < 400,000	5.30 M
400,000 < U < 750,000	7.90 M

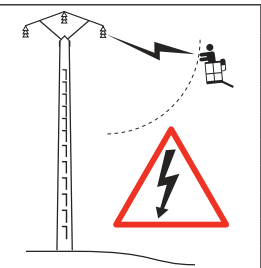

The diagram illustrates a vertical power line with a platform suspended nearby. A lightning bolt symbol indicates a risk of electrocution. A warning sign with a lightning bolt is shown below the platform. A dashed line indicates the safety distance between the platform and the power line.

⚠ IMPORTANT ⚠

Do not use this machine during lightning storms, snow storms, during frosty periods or in hazardous weather conditions. In case of strong wind exceeding 45 km/h, do not make any movement that may endanger the platform's stability.

- To visually recognise this wind speed, refer to the empirical wind evaluation scale below:

BEAUFORT scale (wind speed at a height of 10 m on a flat site)						
Force	Type of wind	Speed (knots)	Speed (km/h)	Speed (m/s)	Effects on Land	Sea conditions
0	Calm	0 - 1	0 - 1	<0.3	Smoke rises vertically.	Sea is like a mirror.
1	Light air	1 - 3	1 - 5	0.3 - 1.5	Smoke indicates direction of wind.	Ripples with appearance of scale, no foam crests.
2	Light breeze	4 - 6	6 - 11	1.6 - 3.3	Wind felt on face, leaves rustle.	Short wavelets, but pronounced.
3	Gentle breeze	7 - 10	12 - 19	3.4 - 5.4	Leaves and small twigs in constant motion.	Very small waves, crests begin to break.
4	Moderate breeze	11 - 16	20 - 28	5.5 - 7.9	Wind raises dust and loose pieces of paper; small branches are moved.	Small waves, becoming longer, numerous whitecaps.
5	Fresh breeze	17 - 21	29 - 38	8 - 10.7	Small trees in leaf begin to sway.	Wavelets form on inland waters; moderate waves, taking longer form.
6	Strong breeze	22 - 27	39 - 49	10.8 - 13.8	Large branches in motion, whistling heard in overhead wires, umbrella use becomes difficult.	Larger waves forming, whitecaps everywhere, some spray.
7	Near gale	28 - 33	50 - 61	13.9 - 17.1	Whole trees in motion, inconvenience felt when walking against the wind.	Sea heaps up; white foam from breaking waves begins to be blown in streaks along the direction of the wind.
8	Gale	34 - 40	62 - 74	17.2 - 20.7	Wind breaks twigs off trees; impedes progress.	Moderately high waves of greater length; edges of crests begin to break into spindrift.
9	Strong gale	41 - 47	75 - 88	20.8 - 24.4	Wind damages roofs (chimneys, slates, etc.).	High waves, crests of waves begin to topple, streaks of foam; reduced visibility.
10	Storm	48 - 55	89 - 102	24.5 - 28.4	Seldom experienced inland; trees uprooted; considerable structural damage occurs.	Very high waves; white streaks of foam; reduced visibility.
11	Violent storm	56 - 63	103 - 117	28.5 - 32.6	Very rare, widespread damage.	Exceptionally high waves able to hide medium sized ships from view, reduced visibility.
12	Hurricane	64 +	118 +	32.7 +	Devastating damage.	Sea completely white; air filled with foam and spray, very reduced visibility.

D - VISIBILITY

- Ensure good visibility on your route at all times. To increase your visibility, you can move forwards with the jib arm slightly raised (beware of the risk of falls in the basket from knocking into a low doorway, overhead electric wires, travelling cranes, highway bridges, rail tracks or any obstacle in the area in front of the platform). In reverse, look directly behind you. At all events, avoid reversing long distances.
- If visibility of your road is inadequate, ask someone to help, standing outside the area in which the platform will be moving, and make sure you always have a good view of this person.

E - STARTING-UP THE ENGINE-POWERED PLATFORM

SAFETY INSTRUCTIONS

- If using an emergency battery for start-up, use a battery with the same characteristics and respect battery polarity when connecting it. Connect the positive terminal first, and then the negative terminal.

⚠ IMPORTANT ⚠

Failure to respect polarity between batteries can cause serious damage to the electrical circuit.

The electrolyte in the battery may produce an explosive gas.

Avoid flames and generation of sparks close to the batteries. Never disconnect a battery while it is being charged.

INSTRUCTIONS: 2 - DESCRIPTION.

E - STARTING UP THE ELECTRIC-POWERED PLATFORM

SAFETY INSTRUCTIONS

- Do not use the platform if the battery is discharged to the point that movements are slowed down. In certain cases, the platform may stop (2 - DESCRIPTION for the charge level not to be exceeded).

INSTRUCTIONS: 2 - DESCRIPTION.

F - OPERATING THE PLATFORM

SAFETY INSTRUCTIONS

⚠ IMPORTANT ⚠

Operators should be aware of the risks connected with using the platform, notably:

- Risk of losing control.

- Risk of losing lateral and frontal stability of the platform.

The operator must remain in control of the platform.

- Do not carry out operations which exceed the capacities of your platform.
- Familiarise yourself with the platform on the terrain where it will be used.
- Ensure that the brakes work efficiently when stopping a travelling movement, taking into account the braking distances.
- Drive smoothly and adapt the platform speed to the operating conditions (site configuration, load in the basket).
- In all circumstances make sure you are in control of your speed.
- Take extreme care when manoeuvring the platform with the basket in the high position. Ensure that there is sufficient visibility.
- Take bends slowly.
- Look where you are going and always make sure you have good visibility along the route.
- Drive round obstacles.
- Never drive on the edge of a ditch or steep slope.
- Travel slowly on damp, slippery or uneven terrain or on truck ramps.
- Always remember that the hydraulic steering is very sensitive to movements.
- Never leave the I.C. engine on when the platform is unattended.
- Whatever your travelling speed, you must reduce the speed as much as possible before stopping.
- The platform should be operated in an area free of any obstructions or danger when it is lowered to the ground.
- Pay attention to structures, objects and people when manoeuvring.
- The operator using the platform must be aided on the ground by a person with adequate training.
- Remain within the limits of the platform's diagram (↖ 2 - DESCRIPTION).
- Do not load the basket if the platform needs to travel on a steep slope.

INSTRUCTIONS

- When moving the platform a long distance, always travel in transport position or with the scissors in the low position (↖ 2 - DESCRIPTION).
- DIESEL PLATFORM: Engage the appropriate gear (↖ 2 - DESCRIPTION).

G - STOPPING THE PLATFORM

SAFETY INSTRUCTIONS

- Never leave the ignition key in the platform during the operator's absence.
- Make sure that the platform is not stopped in any position that will interfere with the traffic flow and in particular the platform should not be less than one metre from a railway track.
- In the event of prolonged parking on a site, protect the platform from bad weather, particularly from frost (DIESEL PLATFORM: Check the level of antifreeze), and close and lock all the platform cowlings (if applicable).
- Park the platform on level ground.

INSTRUCTIONS: ↖ 2 - DESCRIPTION.

DIESEL PLATFORM

- Before stopping the platform after a long working period, leave the I.C. engine idling for a few moments, to allow the coolant and oil to lower the temperature of the I.C. engine and transmission.

⚠ IMPORTANT ⚠

Do not forget this precaution, in the event of frequent stops or warm stalling of the engine, or else the temperature of certain parts will rise significantly due to the stopping of the cooling system, with the risk of badly damaging such parts.

INSTRUCTIONS FOR WELDING AND BLOW TORCH WORK ON AN EXTERNAL STRUCTURE

⚠ IMPORTANT ⚠

Ensure that there are no hydraulic or electrolyte leaks on the platform.

⚠ IMPORTANT ⚠

When welding, work in the opposite direction from the control console to avoid sparks damaging it.

Any welding and cutting (blow torch) work from the basket on a building's metallic structures requires the following precautions to be taken:

A - WITH AN ELECTRICAL WELDING SET

- It is essential that the machine has a discharge braid connecting the chassis of the platform to the ground.
- The external structure to be welded must, without fail, be grounded. If the above conditions are observed, the platform can, in this case, be in contact with the structure or the elements to be welded without damaging the electronic components.
- The power supply to the welding equipment must be via a grounded socket, including the extension lead if required.
- In all cases, make sure that there are no electric arcs in the basket or on the platform (contact between the rod or torch and ground plug of the welding equipment). For this the ground plug of the welding equipment must never be placed on the platform's basket; it must only be placed as close as possible to the part to be welded.
- Switch off the welding equipment before disconnecting the ground clamp from the element or elements to be welded.

B - WITH A BLOW TORCH

- Attach the blow torch's bottles to the basket's frame.
- Sparks and clippings must not be directed towards the batteries.
- Do not set the blow torch down on the floor of the basket while it is still operating or point it towards the control panel or its power supply harness.

PLATFORM MAINTENANCE INSTRUCTIONS

GENERAL INSTRUCTIONS

- Read the operator's manual carefully.
- Wear clothes suitable for the maintenance of the lift truck, avoid wearing jewellery and loose clothes. Tie and protect your hair, if necessary.
- DIESEL PLATFORM:
 - Make sure the area is adequately ventilated before starting up the platform.
 - Stop the engine before conducting any work on the platform, switch off the platform and turn the battery cut-off to the OFF position (according to model).
- ELECTRIC PLATFORM: Switch off the platform before carrying out any work on the platform and turn the battery cut-off to the OFF position.
- Carry out all repairs immediately, even if the repairs concerned are minor.
- Repair all leaks immediately, even if the leak concerned is minor.
- Ensure that process materials and of spare parts are disposed in all safely and in an ecological manner.
- Be careful of the risk of burning and splashing (exhaust, radiator, engine, etc.).

MAINTENANCE

- Perform the periodic service (≤ 3 - MAINTENANCE) to keep your platform in good working condition. Failure to perform the periodic service may void the contractual guarantee.

MAINTENANCE LOGBOOK

- The maintenance operations carried out in accordance with the recommendations given in chapter 3 - MAINTENANCE and the other inspection, servicing or repair operations or modifications performed on platform shall be recorded in a maintenance logbook. The entry for each operation shall include details of the date of the works, the names of the individuals or companies having performed them, the type of operation and its frequency, if applicable. The part numbers of any platform items replaced shall also be indicated.

LUBRICANT AND FUEL LEVELS

- Use the recommended lubricants (never use contaminated lubricants).

DIESEL PLATFORM

- Do not fill the fuel tank when the engine is running.
- Only fill up the fuel tank in areas specified for this purpose.
- Do not smoke or approach the platform with a flame, when the fuel tank is open or is being filled.

BATTERY ELECTROLYTE LEVEL (ELECTRIC PLATFORM)

- Check the electrolyte level of the battery or batteries.



Ensure you take all the safety precautions when performing this operation (≤ 3 - MAINTENANCE).

HYDRAULICS

- Any work on the hydraulic circuit is forbidden except for the operations described in chapter 3 - MAINTENANCE.
- Do not attempt to loosen connections, hoses or any hydraulic component with the circuit under pressure.



COUNTERBALANCE VALVE: It is dangerous to change the setting or remove the counterbalance valves or safety valves which may be fitted to your platform cylinders.

These operations must only be performed by approved personnel (consult your dealer).

HYDRAULIC ACCUMULATOR (according to model): dismantling hydraulic accumulators and their pipes that may be fitted on your platform is dangerous.

These operations must only be performed by approved personnel (consult your dealer).

ELECTRICITY

- Do not drop metallic items on the battery (between the positive and negative terminal(s)).
- Disconnect the battery or batteries before working on the electrical circuit.
- The control panels on the ground and in the basket and all other electrical control boxes must only be opened by authorised personnel.

TILT SENSOR

⚠ IMPORTANT ⚠

Some platforms are fitted with a tilt sensor attached to the turn table (⚠ 2 - DESCRIPTION: CONTROL PANEL AND SAFETY DEVICES AT GROUND LEVEL); always carry out an initialisation after dismantling/refitting the tilt sensor. Refer to the platform repair manual.

Some platforms are fitted with a tilt sensor that is integrated in the ground level control panel (⚠ 2 - DESCRIPTION: CONTROL PANEL AND SAFETY DEVICES AT GROUND LEVEL); always carry out a calibration of the tilt sensor after dismantling/refitting or loosening/tightening the ground level control panel, its mounting plates or fixing screws. Refer to the platform repair manual.

WELDING ON THE ACCESS PLATFORM

- Disconnect the battery or batteries before welding on the platform.
- When carrying out electric welding work on the platform, connect the negative cable from the welding equipment directly to the part being welded, so as to avoid high tension current passing through the alternator or the ring gear.
- If the platform is equipped with electronic controls, disconnect them before starting to weld, to avoid the risk of causing irreparable damage to electronic components.

⚠ IMPORTANT ⚠

Welding operations for the purposes of maintenance or repairs must only be carried out by persons authorised by MANITOU.

WASHING THE PLATFORM

- Clean the platform or at least the area concerned before any intervention.
- Remember to close and lock (if applicable) all the platform's cowlings.
- When cleaning with a high pressure cleaner, avoid air from entering the engine, the piston rod wiper seals, the hinges, the structural components and the electrical connections, etc.
- If necessary, protect components likely to be damaged, and in particular the electrical components (variable speed drive, charger) and electrical connections and the injection pump from penetration by water, steam or cleaning products.
- Dry the electrical components.
- Clean the platform of any fuel, oil or grease trace.
- Grease the axles, pins, ring gear, etc.

IF THE PLATFORM IS NOT TO BE USED FOR A LONG TIME

INTRODUCTION

The following recommendations are intended to prevent the platform from being damaged when it is withdrawn from service for an extended period.

⚠ IMPORTANT ⚠

Procedures to follow if the platform is not to be used for a long time and for starting it up again afterwards must be performed by your dealership. This period of long-term stoppage must not exceed 12 months.

PREPARING THE PLATFORM

- Clean the platform thoroughly.
- Check and repair any leaks of fuel, oil, water, etc.
- Replace or repair any worn or damaged parts.
- Touch up the paintwork if necessary.
- Make sure the cylinder rods are in the retracted position (if applicable).
- Shut down the platform.
- Release the pressure in the hydraulic circuits.

PROTECTING THE ENGINE (DIESEL PLATFORM)

- Fill the tank with fuel (↩ 3 - MAINTENANCE).
- Replace the engine oil and oil filter (↩ 3 - MAINTENANCE).
- Drain and replace the coolant (↩ 3 - MAINTENANCE).
- Disconnect the battery and store it in a safe place away from the cold, after charging it to a maximum.
- Block the outlet with waterproof adhesive tape.
- Remove the belts and store them in a safe place.
- Disconnect the engine cut-off solenoid on the injection pump and carefully insulate the connection.

BATTERY CHARGING (ELECTRIC PLATFORM)

- In order to preserve battery life and capacity, check them periodically and keep the charge level constant (↩ 2 - DESCRIPTION).
- Do not leave the battery charger connected during a lightning storm.

PROTECTING THE PLATFORM

- Protect cylinder rods which are not be retracted from corrosion.
- Wrap the wheels.

NOTE: If the platform is to be stored outdoors, cover it with a waterproof tarpaulin.

BRINGING THE PLATFORM BACK INTO SERVICE

DIESEL PLATFORM

- Remove the protection from the cylinder rods and wheels.
- Refit and reconnect the battery.
- Remove the waterproof adhesive tape from the exhaust outlet.
- Empty and replace the fuel and replace the fuel filter (↩ 3 - MAINTENANCE).
- Refit the belts and adjust their tension (↩ 3 - MAINTENANCE).
- Reconnect the engine cut-off solenoid.

⚠ IMPORTANT ⚠

Make sure the area is adequately ventilated before starting up the platform.

- Start up the platform, following the safety instructions and regulations.
- Perform the daily maintenance operations (↩ 3 - MAINTENANCE).

DIESEL AND ELECTRIC PLATFORM

- Lubricate the platform completely (↩ 3 - MAINTENANCE).
- Carry out all the lifting system's hydraulic movements right up to the limit switches for each cylinder.

DISPOSING OF THE PLATFORM

⚠ IMPORTANT ⚠

Consult your dealer before disposing of your platform.

RECYCLING OF MATERIALS

METALS

- Metals are 100 % recoverable and recyclable.

PLASTICS

- Plastic parts are identified with a marking in accordance with current regulations.
- A limited range of materials is used to simplify the recycling process.
- The majority of plastic components are made of “thermoplastic” plastics, which are easily recycled by melting, granulating or grinding.

RUBBER

- Tyres and seals can be ground for use in cement manufacture or to obtain reusable granules.

GLASS

- Glass items can be removed and collected for processing by glaziers.

ENVIRONMENTAL PROTECTION

By entrusting the maintenance of your platform to the MANITOU network, the risk of pollution is limited and the contribution to environmental protection is made.

WORN OR DAMAGED PARTS

- Do not dump them in the countryside.
- MANITOU and its network have signed-up to a scheme of environmental protection through recycling.

USED OIL

- The MANITOU network organises the collection and processing of used oil.
- By handing over your waste oil to MANITOU, the risk of pollution is limited.

USED BATTERIES

- Do not throw away batteries, as they contain metals that are harmful for the environment.
- Return them to the MANITOU network or any other approved collection point.

NOTE: MANITOU aims to manufacture platforms that provide the best performance and limit polluting emissions.

2 - DESCRIPTION

2 - DESCRIPTION

"CE" DECLARATION OF CONFORMITY 260 TJ	2-4
"CE" DECLARATION OF CONFORMITY 280 TJ — No. 950123	2-5
"CE" DECLARATION OF CONFORMITY 280 TJ — No. 950124	2-6
STICKERS	2-8
IDENTIFICATION OF THE PLATFORM	2-20
CHARACTERISTICS	2-22
DIMENSIONS AND DIAGRAM 260 TJ	2-26
DIMENSIONS AND DIAGRAM 280 TJ	2-28
SAFETY COMPONENTS	2-30
CONTROL PANEL AND SAFETY DEVICES AT GROUND LEVEL	2-31
CONTROL PANEL AND SAFETY DEVICES IN THE BASKET	2-32
REMOTE CONTROL UNIT	2-33
SCREEN DISPLAY - DESCRIPTION OF PAGES	2-53
DEFINITION OF SUB-MENUS	2-56
USING THE PLATFORM	2-60
TRANSPORTING THE PLATFORM	2-66
RESCUE PROCEDURE	2-70
OPTIONS	2-74

DECLARATION "CE" DE CONFORMITE (originale) "EC" DECLARATION OF CONFORMITY (original) (1)

- (2) Constructeur, **manufacturer:** Manitou BF
(3) Adresse, **Address:** 430, RUE DE L'AUBINIÈRE - B.P 10249
44158 - ANCENIS - CEDEX - FRANCE
(4) Titulaire du dossier technique, **Holder of the technical file:** Manitou BF
(3) Adresse, **Address:** 430, RUE DE L'AUBINIÈRE - B.P 10249
44158 - ANCENIS - CEDEX - FRANCE
(5) Le constructeur déclare que la machine décrite ci-après, **The manufacturer declares that the machine described below: 260 TJ**
 (6) - Est conforme aux directives suivantes et à leurs transpositions en droit national (si applicables), **Complies with the following directives and their transpositions into national law (if applicable):**

2006/42/CE

- (7) - Pour les machines annexe IV, **For annex IV machines:**
(8) - Numéro d'attestation, **Certificate number:** 0062 5131 xxx xx xx xxxx
(9) - Organisme notifié, **Notified body:** BUREAU VERITAS INT. - 61-71 BD DU CHATEAU
92200 NEUILLY-SUR-SEINE

2000/14/CE + 2005/88/CE

- (10) - Procédure appliquée, **Applied procedure:**
(9) - Organisme notifié, **Notified body:** SNCH - 11 ROUTE DU LUXEMBOURG
5201 SANDWEILER

- (11) - Niveau de puissance acoustique, **Sound power level:**

- (12) Mesuré, **Measured:** dB (A)
(13) Garanti, **Guaranteed:** dB (A)

2004/108/CE jusqu'au 19/04/2016 et 2014/30/UE à partir du 20/04/2016

- (14) - Normes harmonisées utilisées, **Harmonised standards used:**
EN12895
 (15) - Normes ou dispositions techniques utilisées, **Standards or technical provisions used:**

(16) - Fait à, **Done at:**

(17) - Date, **Date:**

(18) - Nom du signataire, **Name of signatory:**

(19) - Fonction, **Function:**

(20) - Société, **Company:**

(21) - Signature, **Signature:**

DECLARATION "CE" DE CONFORMITE (originale)
"EC" DECLARATION OF CONFORMITY (original) (1)

- (2) Constructeur, **manufacturer:** Manitou BF
(3) Adresse, **Address:** 430, RUE DE L'AUBINIÈRE - B.P 10249
44158 - ANCENIS - CEDEX - FRANCE
(4) Titulaire du dossier technique, **Holder of the technical file:** Manitou BF
(3) Adresse, **Address:** 430, RUE DE L'AUBINIÈRE - B.P 10249
44158 - ANCENIS - CEDEX - FRANCE
(5) Le constructeur déclare que la machine décrite ci-après, **The manufacturer declares that the machine described below: 280 TJ**

- (6) - Est conforme aux directives suivantes et à leurs transpositions en droit national (si applicables), **Complies with the following directives and their transpositions into national law (if applicable):**

2006/42/CE

- (7) - Pour les machines annexe IV, **For annex IV machines:**
(8) - Numéro d'attestation, **Certificate number:** 0526 5131 xxx xx xx xxxx
(9) - Organisme notifié, **Notified body:** CETIM - 52 AVENUE FELIX LOUAT
BP 80067 - 60304 SENLIS CEDEX

2000/14/CE + 2005/88/CE

- (10) - Procédure appliquée, **Applied procedure:**
(9) - Organisme notifié, **Notified body:** SNCH - 11 ROUTE DU LUXEMBOURG
5201 SANDWEILER

- (11) - Niveau de puissance acoustique, **Sound power level:**

- (12) Mesuré, **Measured:** dB (A)
(13) Garanti, **Guaranteed:** dB (A)

2004/108/CE jusqu'au 19/04/2016 et 2014/30/UE à partir du 20/04/2016

- (14) - Normes harmonisées utilisées, **Harmonised standards used:**
EN12895
 (15) - Normes ou dispositions techniques utilisées, **Standards or technical provisions used:**

(16) - Fait à, **Done at:**

(17) - Date, **Date:**

(18) - Nom du signataire, **Name of signatory:**

(19) - Fonction, **Function:**

(20) - Société, **Company:**

(21) - Signature, **Signature:**

DECLARATION "CE" DE CONFORMITE (originale)
"EC" DECLARATION OF CONFORMITY (original) (1)

- (2) Constructeur, **manufacturer:** Manitou BF
(3) Adresse, **Address:** 430, RUE DE L'AUBINIÈRE - B.P 10249
44158 - ANCENIS - CEDEX - FRANCE
(4) Titulaire du dossier technique, **Holder of the technical file:** Manitou BF
(3) Adresse, **Address:** 430, RUE DE L'AUBINIÈRE - B.P 10249
44158 - ANCENIS - CEDEX - FRANCE
(5) Le constructeur déclare que la machine décrite ci-après, **The manufacturer declares that the machine described below: 280 TJ**

- (6) - Est conforme aux directives suivantes et à leurs transpositions en droit national (si applicables), **Complies with the following directives and their transpositions into national law (if applicable):**

2006/42/CE

- (7) - Pour les machines annexe IV, **For annex IV machines:**

(8) - Numéro d'attestation, **Certificate number:** 0062 5131 xxx xx xx xxxx

(9) - Organisme notifié, **Notified body:** BUREAU VERITAS INT. - 61-71 BD DU CHATEAU
92200 NEUILLY-SUR-SEINE

2000/14/CE + 2005/88/CE

- (10) - Procédure appliquée, **Applied procedure:**

(9) - Organisme notifié, **Notified body:** SNCH - 11 ROUTE DU LUXEMBOURG
5201 SANDWEILER

- (11) - Niveau de puissance acoustique, **Sound power level:**

(12) Mesuré, **Measured:** dB (A)

(13) Garanti, **Guaranteed:** dB (A)

2004/108/CE jusqu'au 19/04/2016 et 2014/30/UE à partir du 20/04/2016

- (14) - Normes harmonisées utilisées, **Harmonised standards used:**
EN12895

- (15) - Normes ou dispositions techniques utilisées, **Standards or technical provisions used:**

(16) - Fait à, **Done at:**

(17) - Date, **Date:**

(18) - Nom du signataire, **Name of signatory:**

(19) - Fonction, **Function:**

(20) - Société, **Company:**

(21) - Signature, **Signature:**

STICKERS

⚠ IMPORTANT ⚠

*Clean all stickers so that they are legible.
Any stickers which are illegible or damaged must be replaced.
Check that the stickers are present after replacing any spare parts.*

1 - WHITE ARROW	Part No. 833553	2-10
2 - BLACK ARROW	Part No. 833554	2-10
3 - BASKET SAFETY INSTRUCTIONS 260 TJ	Part No. 52514665	2-10
4 - BASKET SAFETY INSTRUCTIONS 280 TJ	Part No. 318457	2-10
5 - GROUND SAFETY INSTRUCTIONS	Part No. 685608	2-11
6 - WHEEL LOAD 260 TJ	Part No. 52523351	2-11
7 - WHEEL LOAD 280 TJ	Part No. 833552	2-11
8 - DANGER OF CRUSHING HANDS	Part No. 676988	2-11
9 - DANGER KEEP AWAY	Part No. 679450	2-11
10 - DANGER OF CRUSHING	Part No. 679452	2-12
11 - DANGER ROTATING PART	Part No. 683108	2-12
12 - DANGER HOT COMPONENT	Part No. 683112	2-12
13 - WASHING INSTRUCTION	Part No. 313672	2-12
14 - HARNESS ATTACHMENT POINT (first version)	Part No. 684503	2-12
15 - HARNESS ATTACHMENT POINT (second version)	Part No. 834438	2-13
16 - LOCATION OF EMERGENCY STOP BUTTONS	Part No. 834644	2-13
17 - JIB ANGLE	Part No. 833523	2-13
18 - JIB ZERO/ X-Y /TURNABLE ORIENTATION	Part No. 833675	2-13
19 - BACKUP PUMP	Part No. 833549	2-14
20 - EMERGENCY CONTROL PROCEDURE (DISTRIBUTOR)	Part No. 833548	2-14
21 - EMERGENCY CONTROL PROCEDURE (VALVE)	Part No. 833547	2-14
22 - PLATFORM EXTENSION/RETRACTION 260 TJ	Part No. 52515335	2-14
23 - PLATFORM EXTENSION/RETRACTION 280 TJ	Part No. 833703	2-14
24 - ANCHORAGE POINT	Part No. 833041	2-15
25 - HYDRAULIC OIL	Part No. 597652	2-15
26 - DIESEL	Part No. 683437	2-15
27 - ANTIFREEZE (first version)	Part No. 597649	2-15
28 - ANTIFREEZE (second version)	Part No. 52501046	2-15
29 - BATTERY LOCATION	Part No. 52509705	2-16
30 - POWER FUSES (first version)	Part No. 833705	2-16
31 - POWER FUSES (second version)	Part No. 52563677	2-16
32 - PLATFORM KEY LOCATION (depending on version)	Part No. 598897	2-16
33 - REMOTE LUBRICATION	Part No. 834206	2-16
34 - CABLE ADJUSTMENT	Part No. 833559	2-17
35 - FAULT CODES	Part No. 833687	2-17
36 - BRAKE UNIT COILS	Part No. 833702	2-17
37 - TURNABLE UNIT COILS	Part No. 833700	2-17
38 - BASKET/JIB BLOCK COILS AND TILT SENSORS	Part No. 834211	2-17
39 - BASKET/JIB BLOCK COILS AND TILT SENSORS	Part No. 52568744	2-18
40 - TURNABLE ROTATION SENSORS	Part No. 833688	2-18
41 - MAIN JIB ANGLE SENSORS	Part No. 833696	2-18
42 - OVERLOAD SENSORS 260 TJ	Part No. 52523374	2-18
43 - OVERLOAD SENSORS 280 TJ	Part No. 833694	2-18
44 - ABACUS SENSORS 260 TJ	Part No. 52523378	2-19
45 - ABACUS SENSORS 280 TJ	Part No. 833697	2-19
46 - RESET BUTTON (OPTION)	Part No. 52513971	2-19

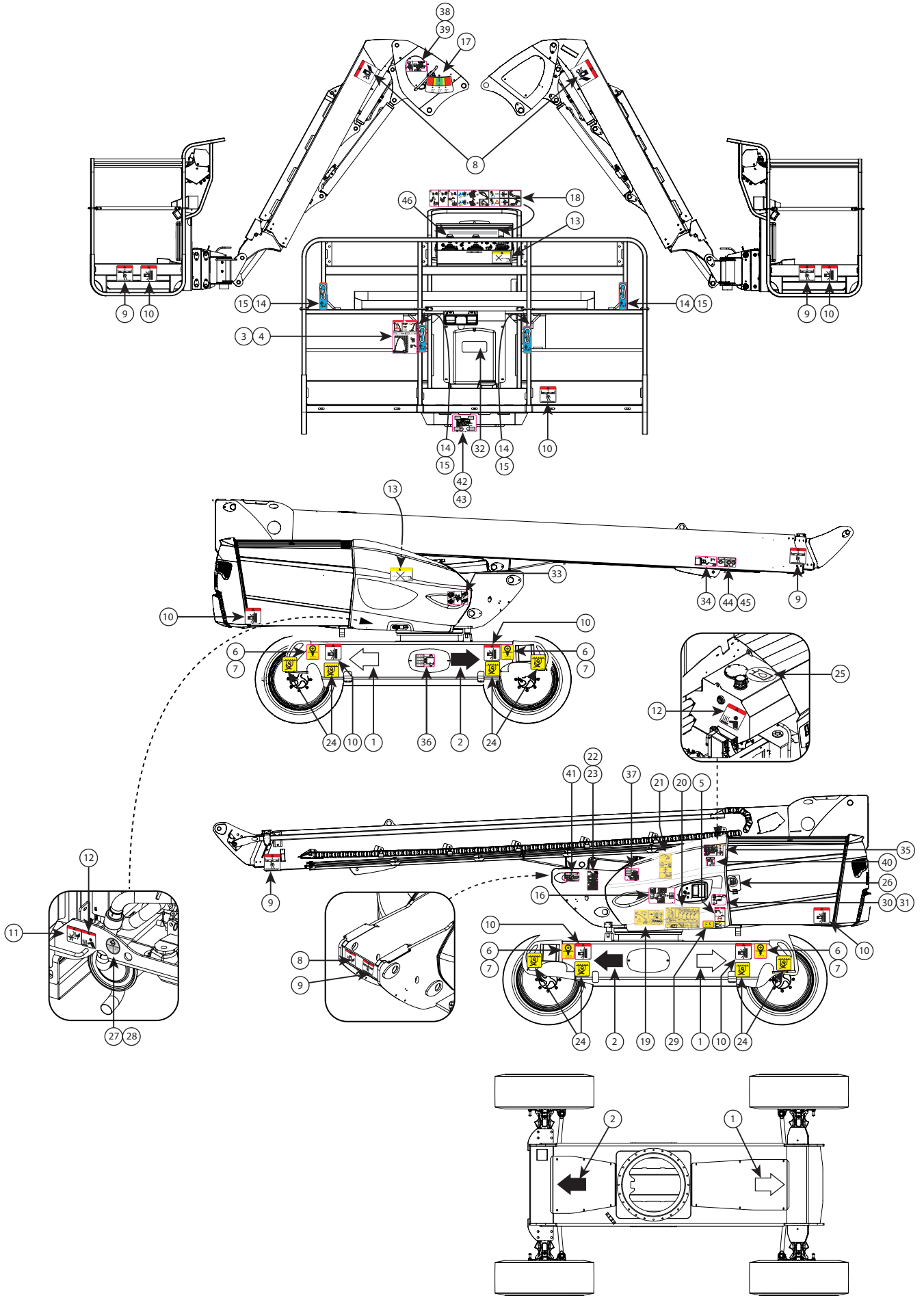

1 - WHITE ARROW

Part No. 833553

Indicates forward driving direction,  PLATFORM OPERATION: TRANSPORT/WORKING POSITION.

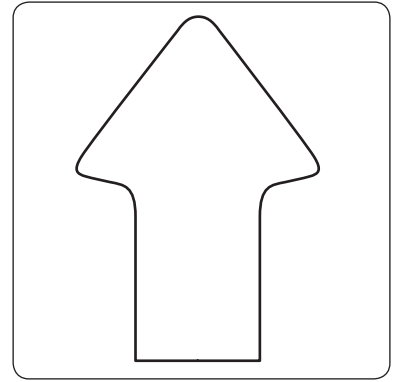

2 - BLACK ARROW

Part No. 833554

Indicates reverse driving direction,  PLATFORM OPERATION: TRANSPORT/WORKING POSITION.

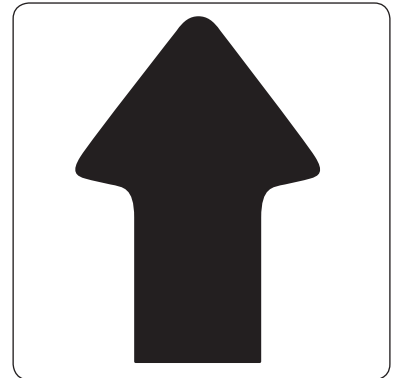

3 - BASKET SAFETY INSTRUCTIONS 260 TJ

Part No. 52514665

4 - BASKET SAFETY INSTRUCTIONS 280 TJ

Part No. 318457

Indicates:

- ①: Maximum load capacity for the basket.
- ②: The safety and operating instructions must be read before starting the platform.
- ③: Operating the platform outside and inside.
- ④: Maximum wind speed when operating outside.
- ⑤: Maximum manual force.
- ⑥: Maximum tilt in the working position.
- ⑦: The risk of electric shock.

NOTE: Each platform has its own specific capacity. Please refer to this sticker for your platform.

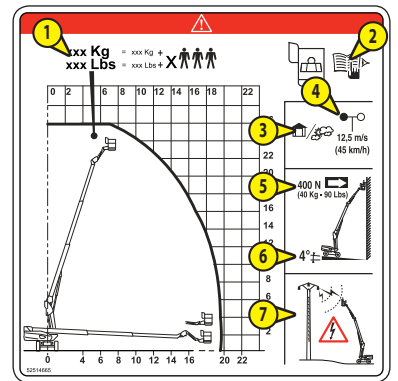

5 - GROUND SAFETY INSTRUCTIONS

Part No. 685608

Indicates:

- ①: The safety and operating instructions must be read before starting the platform.
- ②: The platform must not be towed in the event of breakdown.
- ③: It is strictly forbidden to direct a pressure washer nozzle over the control panels and electrical components.

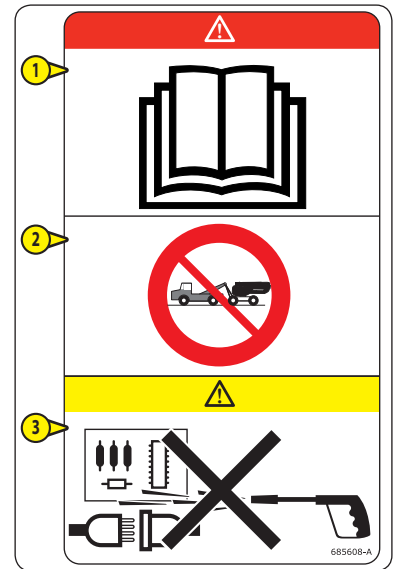

6 - WHEEL LOAD 260 TJ

Part No. 52523351

7 - WHEEL LOAD 280 TJ

Part No. 833552

Indicates the maximum ground load per wheel.

NOTE: Each access platform has its own specific wheel load. Please refer to this sticker to find out the value.

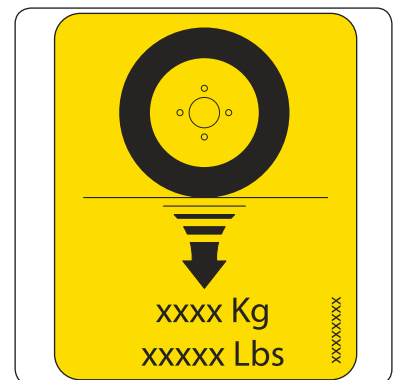

8 - DANGER OF CRUSHING HANDS

Part No. 676988

Indicates that it is strictly forbidden to place your hands or any other part of the body in the lifting mechanism components (arms, jib, basket, etc.).



9 - DANGER KEEP AWAY

Part No. 679450

Indicates that it is strictly forbidden to stand under the lifting mechanism (arm, jib, basket, etc.) or within the access platform's operating area.



10 - DANGER OF CRUSHING

Part No. 679452

Indicates that it is strictly prohibited to stand in this area when the platform is moving. The components on which the stickers are present could crush you.



11 - DANGER ROTATING PART

Part No. 683108

Indicates that there is a high risk of severing fingers with the radiator fan.



12 - DANGER HOT COMPONENT

Part No. 683112

Indicates that there is a high risk of burns in the vicinity (silent engine, internal combustion engine, etc.).



13 - WASHING INSTRUCTION

Part No. 313672

Indicates that it is strictly forbidden to direct a high pressure cleaner nozzle over the control panels and electrical components or on the engine air intake.

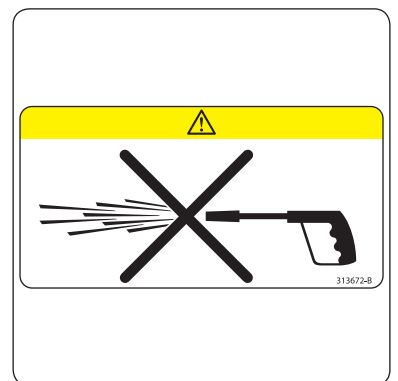

14 - HARNESS ATTACHMENT POINT (first version)

Part No. 684503

Apart from for 260 TJ and up to machine no. 950123 for 280 TJ.

Indicates the location of safety harness attachment points, ◀ SAFETY COMPONENTS: HARNESS ATTACHMENT POINTS.

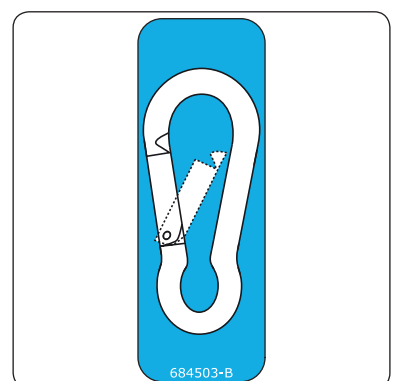

647382 (01/12/2018)
260/280 TJ

15 - HARNESS ATTACHMENT POINT (second version)

Part No. 834438

For 260 TJ and from machine no. 950124 for 280 TJ.

Indicates the location of safety harness attachment points,  SAFETY COMPONENTS: HARNESS ATTACHMENT POINTS.



16 - LOCATION OF EMERGENCY STOP BUTTONS

Part No. 834644

Indicates the location of platform's emergency stop buttons.

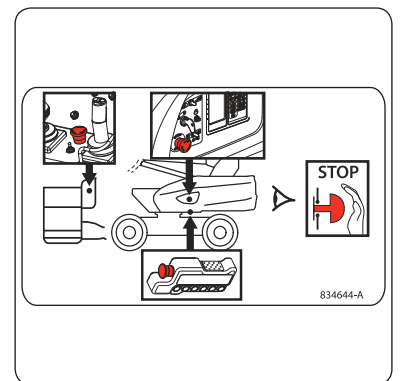

17 - JIB ANGLE

Part No. 833523

Indicates tilt angle of the basket/jib.

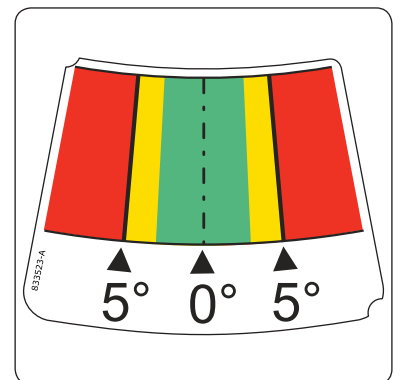

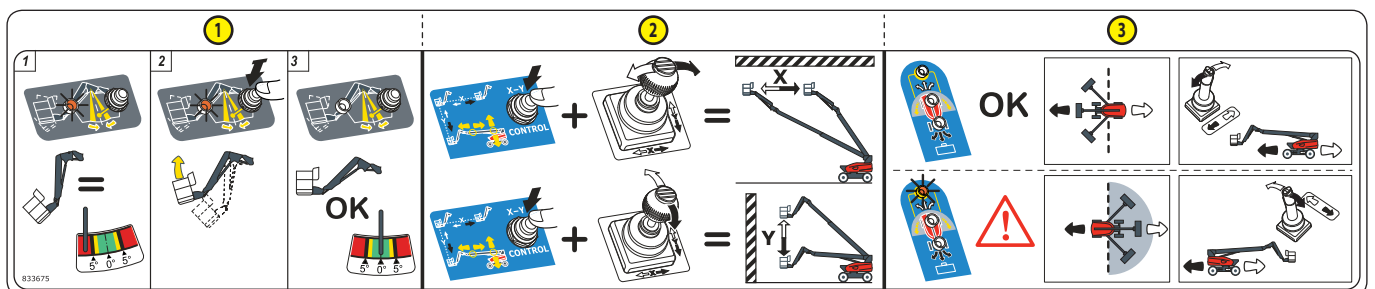

18 - JIB ZERO/ X-Y /TURNTABLE ORIENTATION

Part No. 833675



Indicates the procedure to be followed for:

- 1**: The control indicates the basket/jib assembly zero position,  CONTROL PANEL AND SAFETY DEVICES IN THE BASKET: JIB ZERO WARNING LIGHT AND ZERO POSITION CONTROL BUTTON.
- 2**: The control for functions X and Y,  CONTROL PANEL AND SAFETY DEVICES IN THE BASKET: X-Y FUNCTION BUTTON.
- 3**: Find out the direction of travel when the turntable orientation is less than 90° and when the turntable orientation is greater than 90°,  CONTROL PANEL AND SAFETY DEVICES IN THE BASKET: TURNTABLE ORIENTATION GREATER THAN 90° INDICATOR LIGHT.

19 - BACKUP PUMP

Part No. 833549

Indicates the procedure to be followed for using the backup pump,  RESCUE PROCEDURE.



20 - EMERGENCY CONTROL PROCEDURE (DISTRIBUTOR)

Part No. 833548

Indicates the procedure to be followed for using the emergency controls for proportional distributor,  RESCUE PROCEDURE.



21 - EMERGENCY CONTROL PROCEDURE (VALVE)

Part No. 833547

Indicates the procedure to be followed for using the backup valve,  RESCUE PROCEDURE.

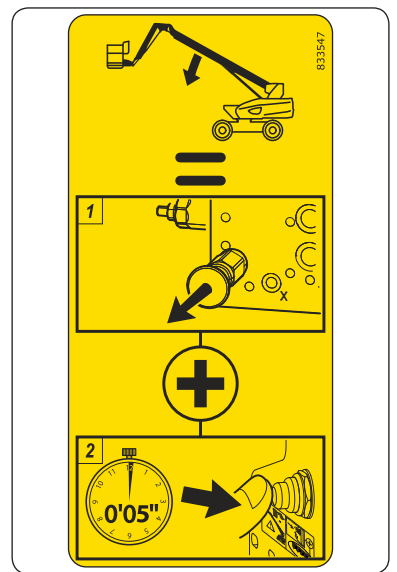

22 - PLATFORM EXTENSION/RETRACTION 260 TJ

Part No. 52515335

23 - PLATFORM EXTENSION/RETRACTION 280 TJ

Part No. 833703

Indicates the procedure to be followed to extend/retract the platform,  OPERATING THE PLATFORM: TRANSPORTING THE PLATFORM.

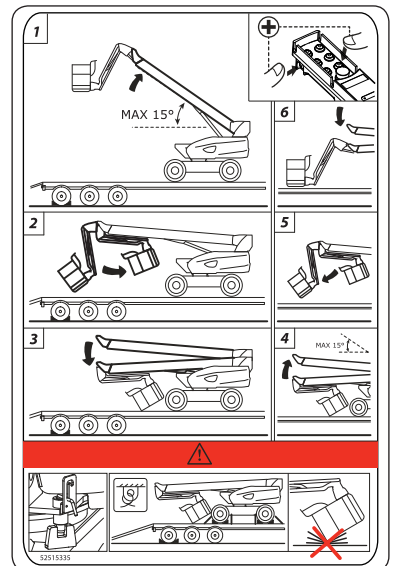

24 - ANCHORAGE POINT

Part No. 833041

Indicates the location of the platform's anchoring points, **OPERATING THE PLATFORM: TRANSPORTING THE PLATFORM.**

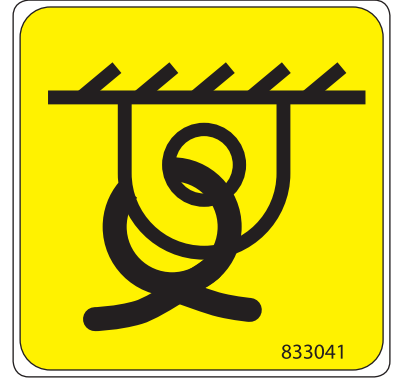

25 - HYDRAULIC OIL

Part No. 597652

This indicates that the tank is intended to contain only hydraulic oil.

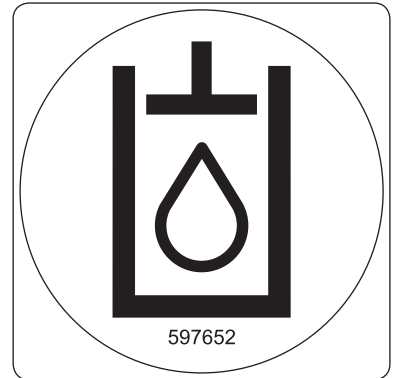

26 - DIESEL

Part No. 683437

This indicates that the tank is intended to contain only vehicle diesel fuel.



27 - ANTIFREEZE (first version)

Part No. 597649

This indicates that there is antifreeze in the IC engine.

- Tick -30 °C (-22 °F) or -40 °C (-40 °F) box if the antifreeze protection has different characteristics from the original product.

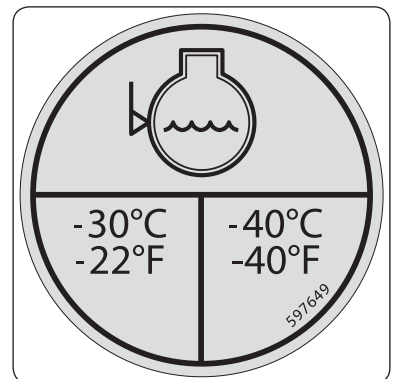

28 - ANTIFREEZE (second version)

Part No. 52501046

This indicates that there is antifreeze in the IC engine.

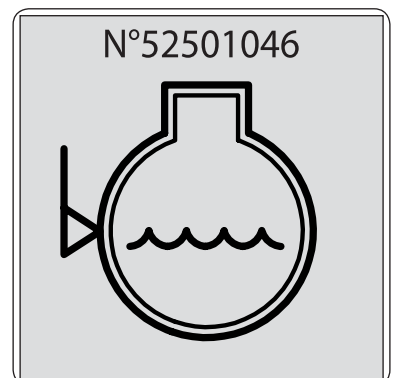

29 - BATTERY LOCATION

Part No. 52509705

Indicates location of battery.

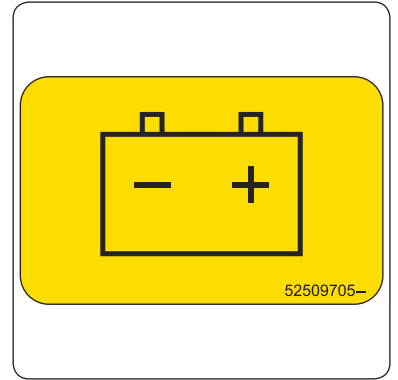

30 - POWER FUSES (first version)

Part No. 833705

Indicates the location, amperage and allocation of power fuses.

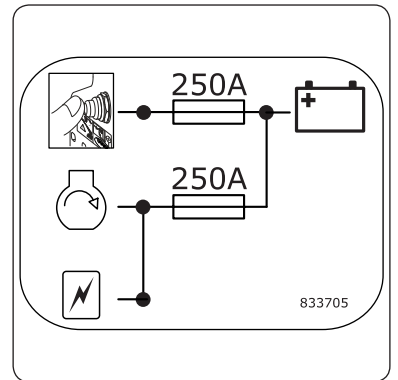

31 - POWER FUSES (second version)

Part No. 52563677

Indicates the location, amperage and allocation of power fuses.

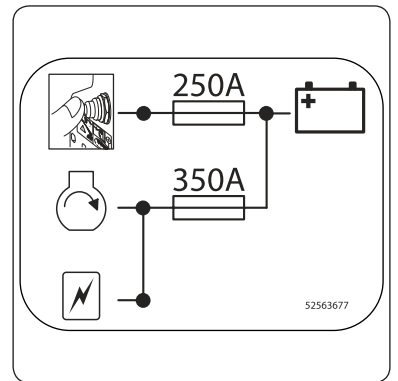

32 - PLATFORM KEY LOCATION (depending on version)

Part No. 598897

Indicates the location of the platform's spare keys.

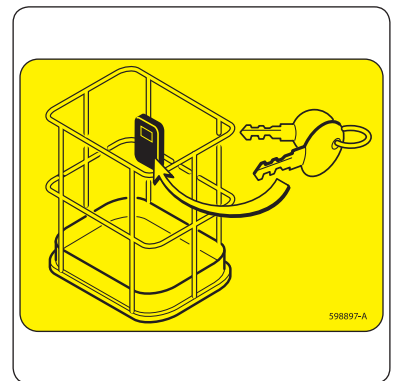

33 - REMOTE LUBRICATION

Part No. 834206

Indicates location and intended use of the remote lubricators for lubricating the turntable ring gear and the structure.

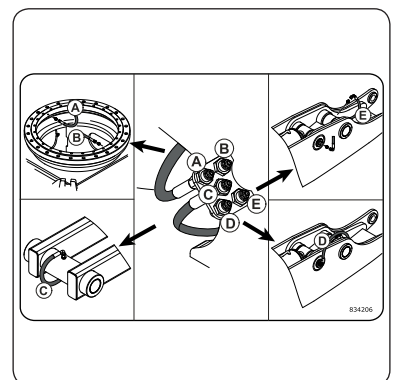

34 - CABLE ADJUSTMENT

Part No. 833559

Indicates the procedure to be followed to adjust the telescope cable tension.

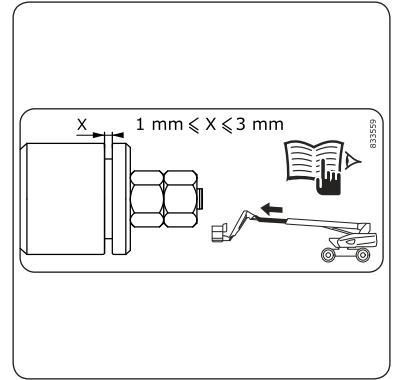

35 - FAULT CODES

Part No. 833687

Indicates the fault codes and location of the electrical components:

- Sensors (AS, DS, IS, TS).
- Electrovalves (EV).
- Solenoid coils (EW).

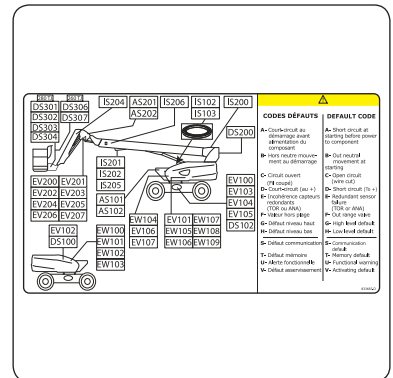

36 - BRAKE UNIT COILS

Part No. 833702

Indicates the location and fault codes of the brake unit coils.

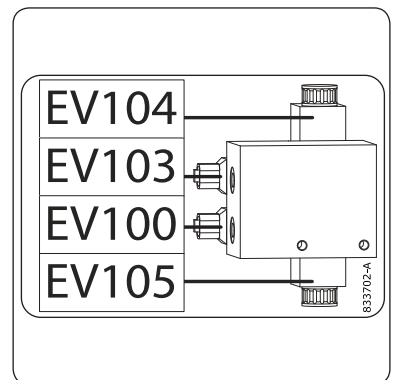

37 - TURNTABLE UNIT COILS

Part No. 833700

Indicates the location and fault codes of the turntable unit coils.

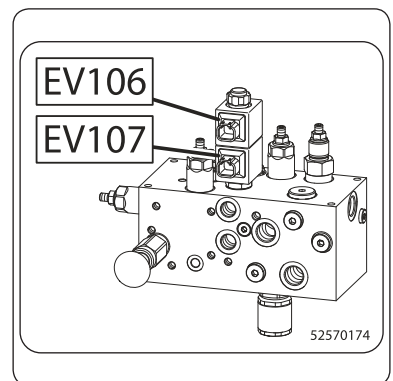

38 - BASKET/JIB BLOCK COILS AND TILT SENSORS

Part No. 834211

260 TJ: First version.

Indicates the location and fault codes of the /basket jib block coils and tilt sensors.

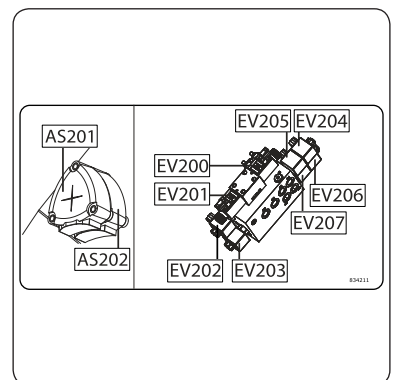

647382 (01/12/2018)
260/280 TJ

39 - BASKET/JIB BLOCK COILS AND TILT SENSORS

Part No. 52568744

260 TJ: Second version.

Indicates the location and fault codes of the /basket jib block coils and tilt sensors.

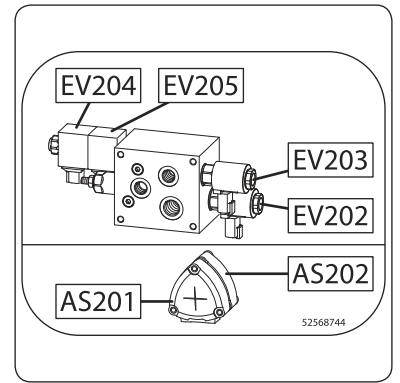

40 - TURNTABLE ROTATION SENSORS

Part No. 833688

Indicates the location and fault codes of the turntable rotation coils.

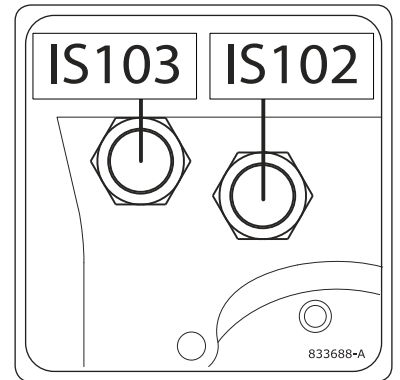

41 - MAIN JIB ANGLE SENSORS

Part No. 833696

Indicates the location and fault code of the main jib angle sensor.

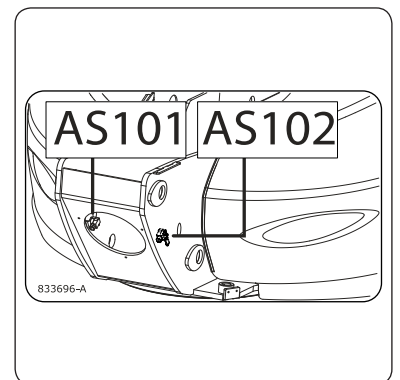

42 - OVERLOAD SENSORS 260 TJ

Part No. 52523374

43 - OVERLOAD SENSORS 280 TJ

Part No. 833694

Indicates the location and fault codes of the overload sensors.

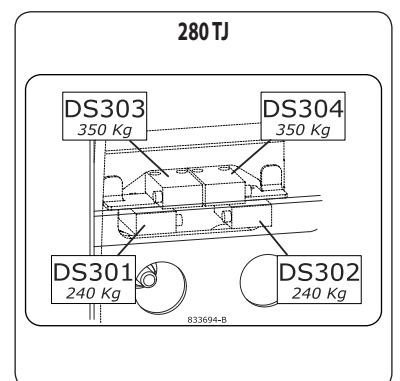
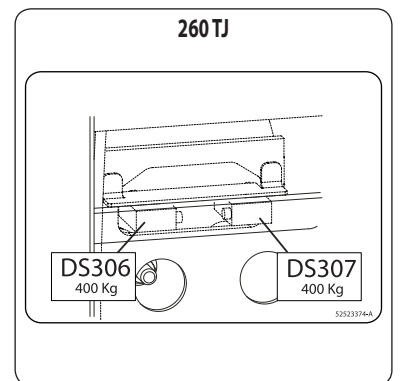

647382 (01/12/2018)
260/280 TJ

Indicates the location and fault codes of the abacus sensors.

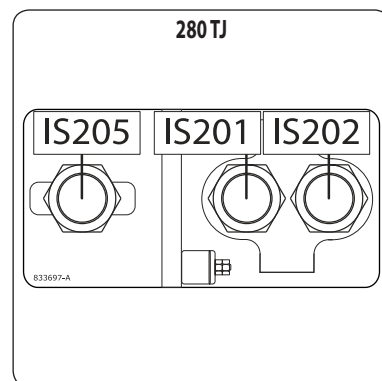
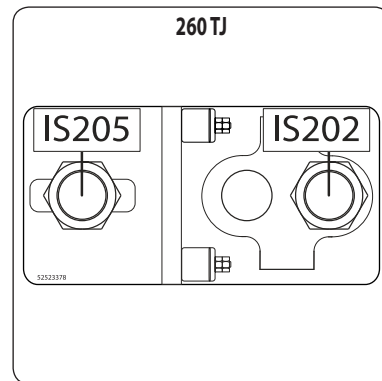

Indicates the location of the reset button of the "SECONDARY PROTECTION SYSTEM option. "SafeManSystem"

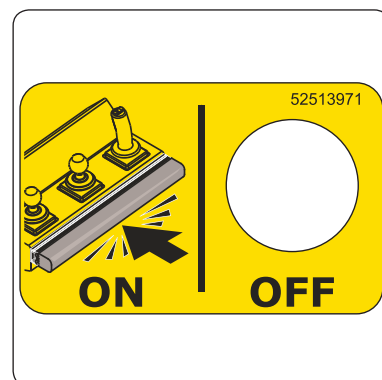

IDENTIFICATION OF THE PLATFORM

As our policy is to promote constant improvement of our products, our range of platforms may undergo certain modifications, without obligation for us to advise our customers.

When you order parts, or when you require any technical information, always specify:

NOTE: In order to have all these numbers on hand when needed, it is recommended that they are noted in the spaces provided, at the time of the delivery of the access platform.

PLATFORM MANUFACTURER'S PLATE

The manufacturer's plate is fixed on the rear of the chassis.

FIRST VERSION:

"Model" Model	
"Serial no." Serial No.	
"Year of manufacture" Year of manufacture	
"Empty weight" Unladen weight	
"Power" Power	
"Voltage" Voltage	
"Inside / Outside" Interior/Exterior	
"Maximum load" Maximum load	
"Maximum no of persons" Maximum number of persons	
"Attachment" Equipment	
"Manual forces" Manual forces	
"Max. tilt" Maximum tilt	
"Max. wind speed" Maximum wind speed	
"Ext. electrical source" External power source	



SECOND VERSION:

"Designation" Designation	
"Year of manufacture" Year of manufacture	
"Model year" Model year	
"Unladen mass" Unladen weight	
"Nominal power" Rated power	
"Voltage" Voltage	
"Inside / Outside" Interior/Exterior	
"Maximum load" Maximum load	
"Maximum number of persons" Maximum number of people	
"Mass of equipment" Equipment weight	
"Manual forces" Manual forces	
"Maximum inclination" Maximum tilt	
"Maximum wind speed" Maximum wind speed	
"Serial Number" Serial number	

All other technical information for your platform is listed in the chapter: CHARACTERISTICS.

ENGINE

"Model" Model	
"Serial No." Serial number	
"Code No." Code number	
"Type" Type	
"Family" Family	
"Approval number" Approval number	

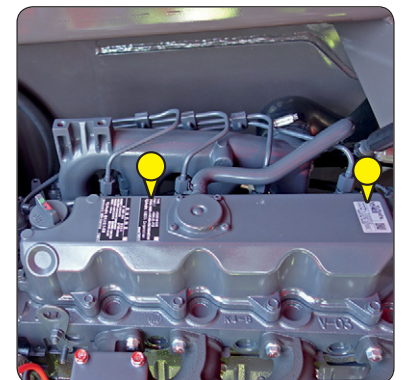

HYDROSTATIC PUMP

"Type" Type	
"MANITOU part number" MANITOU Part No.	
"Serial Number" Serial number	

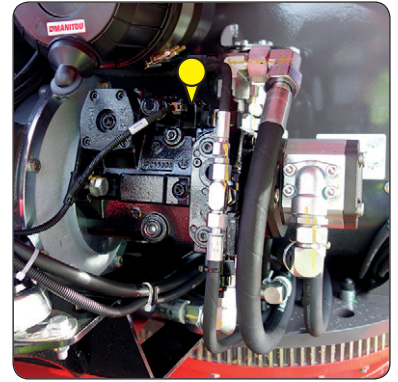

FRONT AXLE

"Type" Type	
"Serial No." Serial number	
"Model" Model	



REAR AXLE

"Type" Type	
"Serial No." Serial number	
"Model" Model	



CHARACTERISTICS

LOAD SPECIFICATIONS		260 TJ	280 TJ	±
Platform				
- Maximum capacity of basket	kg (lbs)	400 (881)	(1)	-
- Maximum wind speed when operating outside	km/h	45		-
- Maximum number of people in the basket (indoor use/ outdoor use)		3/3	(1)	-
- Unladen platform weight	kg (lbs)	16,480 (36,333)	16,650 (36,707)	-
- Authorised maximum tilt	°	4		0,1%
- Traversable slope (+100 kg)	%	34.5		-
- Maximum authorised lateral manual force	N	400		-
Wheels				
- Load on one front wheel (transport position)	kg (lbs)	5,675 (12,512)	5,500 (12,126)	10%
- Load on one rear wheel (transport position)	kg (lbs)	2,550 (5,622)	2,800 (6,173)	10%
- Maximum load on one wheel (working position)	kg (lbs)	9,500 (20,944)	10,500 (23,149)	-
- Bearing surface on ground (hard/soft), wheels SOLIDEAL HAULER-SKS (first version)	cm ²	635/1,471	623/1,160	-
- Punching on ground (hard/soft), wheels SOLIDEAL HAULER- SKS (first version)	daN/cm ²	14.96/6.46	16.85/9.05	-
- Bearing surface on ground (hard/soft), wheels SOLIDEAL SOLIDAIR AWP (second version)	cm ²	446/1,125	472/1,179	-
- Punching on ground (hard/soft), wheels SOLIDEAL SOLIDAIR AWP (second version)	daN/cm ²	21.3/8.44	22.25/8.91	-
(1): DIMENSIONS AND DIAGRAM 280 TJ				
SPEEDS AND MOVEMENTS		260 TJ	280 TJ	±
Driving speed				
- WORKING POSITION speed	km/h	0.8		0.1
- SLOW speed	km/h	1.8		-
- TORTOISE speed	km/h	2.5		0.2
- RAMP speed	km/h	2.5		0.2
- HARE speed	km/h	4.5		0.2
Main jib (telescope extended)				
- Unladen/laden lifting	s	70 / -		5
- Unladen/laden lowering	s	70 / -		5
Main jib (telescope retracted)				
- Unladen/laden lifting	s	45 / -		5
- Unladen/laden lowering	s	42 / -		5
Telescope				
- Unladen/laden extension	s	30 / -		5
- Unladen/laden retraction	s	30 / -		5
Jib 260 TJ				
- Unladen/laden lifting	s	22 / -	-	5
- Unladen/laden lowering	s	18 / -	-	5
Jib (telescope extended) - 280 TJ				
- Unladen/laden lifting	s	-	30 / -	5
- Unladen/laden lowering	s	-	25 / -	5
Jib (telescope retracted) - 280 TJ				
- Unladen/laden lifting	s	-	23 / -	5
- Unladen/laden lowering	s	-	18 / -	5
Jib telescope - 280 TJ				
- Unladen/laden extension	s	-	16 / -	5
- Unladen/laden retraction	s	-	13 / -	5
Turntable				
- 90° rotation (telescope extended/retracted/retracted and main jib raised)	s	50/30/28		5
Basket				
- Rotation 180° (left/right)	s	14/14		5

ENGINE		260 TJ	280 TJ	±
Type		KUBOTA V2403-M		-
Fuel		Diesel		-
Number of cylinders		4		-
Cubic capacity	cm ³	2434		-
Idling speed unladen	rpm	1050		50
Maximum speed unladen	rpm	2550		20
Power at 3,000 rpm	kW	34.1		-
Maximum torque at 1,600 rpm	N.m	162.5		-
Unladen weight	kg (lbs)	184 (406)		5 (11)
Type of cooling		Water		-
Fan		Puller		-
Emissions				
- CO (carbon monoxide)	g/kWh	-		-
- HC + Nox (hydrocarbons + nitrogen dioxide)	g/kWh	-		-
- PT (particles)	g/kWh	-		-
TRANSMISSION				
Hydrostatic pump				
- Type		BOSCH REXROTH A4VG56		-
- Cubic capacity	cm ³	56		-
- Maximum unladen flow rate	L/min	-		-
- Maximum pressure	bar	400		5
Hydrostatic motor				
- Type		BOSCH REXROTH or PARKER		-
- Cubic capacity	cm ³	125		-
Axles				
- Type		DANA SPICER		-
- Reduction ratio		47.06		-
- Pulling force	daN	5850		-
- Front axle differential		45% limited slip		-
- Rear axle differential		Hydraulic locking 100%		-
Number of front/rear steering/directional wheels		2/2		-
Number of front/rear drive wheels		2/2		-
Wheels (first version)				
- Type		SOLIDEAL HAULER-SKS 385/45-28		-
- Dimensions (external Ø x width)	mm	1,086 x 370		-
- Inflation		Foam		-
Wheels (second version)				
- Type		SOLIDEAL SOLIDAIR AWP		-
- Dimensions (external Ø x width)	mm	1,025 x 365		-
- Inflation		Solid tyre		-
BRAKE SYSTEM (parking brake)				
Type of brake		Negative		-
Type of control		Hydraulics		-
Braked wheels front/rear		2/2		-
Release (freewheel mode)		Yes, manual		-
Braking torque	daN.m	3,100 on wheel		-

HYDRAULIC CIRCUIT		260 TJ	280 TJ	±
Auxiliary hydraulic pump				
- Type		BOSCH REXROTH		-
- Cubic capacity	cm ³	28		-
- Maximum unladen flow rate	L/min	70		-
Distributor				
- Type		DANFOSS		-
- Maximum pressure	bar	250		5
Filtration				
- Suction	µm	125		-
- Pressure	µm	10		-
- Operation	µm	10		-
ELECTRIC CIRCUIT		260 TJ	280 TJ	±
Battery				
- Type		EXIDE		-
- Capacity C5	Ah	145		-
- Capacity C20	Ah	-		-
- Rated voltage	V	12		-
Alternator				
- Type		-		-
- Maximum current	A	60		-
- Rated voltage	V	12		-
Starter				
- Type		Electric		-
- Power	kW	1.4		-
- Voltage	V	12		-
BACKUP PUMP		260 TJ	280 TJ	±
- Type		Electric		-
- Cubic capacity	cm ³	2		-
- Power	kW	1.3		-
- Voltage	V	12		-
- Pressure 150 bars	A	-		-
DIMENSIONS		260 TJ	280 TJ	±
Basket				
- External dimensions (length x width)	mm	2,300 x 900		1%
- Floor dimensions (length x width)	mm	2,235 x 840		1%
- Rotation angle right/left	°	90/90		-
Jib displacement angle up/down	°	70.3/63	56.8/62	1%
Turntable rotation angle	°	Continuous rotation		-
Other dimensions: DIMENSIONS AND DIAGRAM 260 TJ and DIMENSIONS AND DIAGRAM 280 TJ				
SOUND AND VIBRATION		260 TJ	280 TJ	±
Acoustic power level LwA (first version / second version)	dB	105/106		-
Vibrations affecting body in the basket				
- Average quadratic values for the body	m/s ²	<0.5		-

EQUIPMENT	260 TJ	280 TJ	±
Orange rotating beacon light	Standard		-
Hour meter	Standard		-
Proportional diesel level display	Standard		-
Fuel/battery low level alarm	Standard		-
Tool box in basket	Standard		-
User interface (diagnostic aid)	Standard		-
Oscillating front axle	Standard		-
Turntable orientation more than 90° indicator light	Standard		-
Remote control unit	Standard		-
Permanent orange rotating beacon light	Option*		-
All movements alarm	Option*		-
Driving/steering alarm	Option*		-
Battery cut-off	Option		-
230 V outlet in basket	Option		-
Generator 110 V/3.5 kW (UK electric power socket)	Option		-
Generator 220 V/3.5 kW	Option		-
Generator 220 V/5 kW	Option		-
Working light	Option		-
Secondary protection system "SafeManSystem"	Option		-
Automatic retraction of telescope (for option "SafeManSystem")	Option*		-
Pipe support	◀ 4 - ACCESSORIES		-
Panel support	◀ 4 - ACCESSORIES		-

*: ◀ DEFINITION OF SUB-MENUS.

DIMENSIONS AND DIAGRAM 260TJ

A	mm	10840	
A1	mm	7880	
B	mm	2800	
C	mm	2,725 (1)	2,710 (2)
C1	mm	2,815 (1)	2,800 (2)
D	mm	2,430 (1)	2,480 (2)
E	mm	430 (1)	415 (2)
F	mm	375 (1)	355 (2)
G	mm	405 (1)	480 (2)

H	mm	2,000 (1)	1,975 (2)
I	mm	4,330 (1)	4,355 (2)
J	mm	4420	
K	mm	5180	
L	mm	9,270 (1)	9,280 (2)
M	mm	6,845 (1)	6,850 (2)
N	mm	4,030 (1)	4,000 (2)
O	mm	5,160 (1)	5,240 (2)
P	°/%	39 / 80 (1)	36 / 73 (2)

(1): Wheels SOLIDEAL HAULER-SKS (first version).

(2): Wheels SOLIDEAL SOLIDAIR AWP (second version).

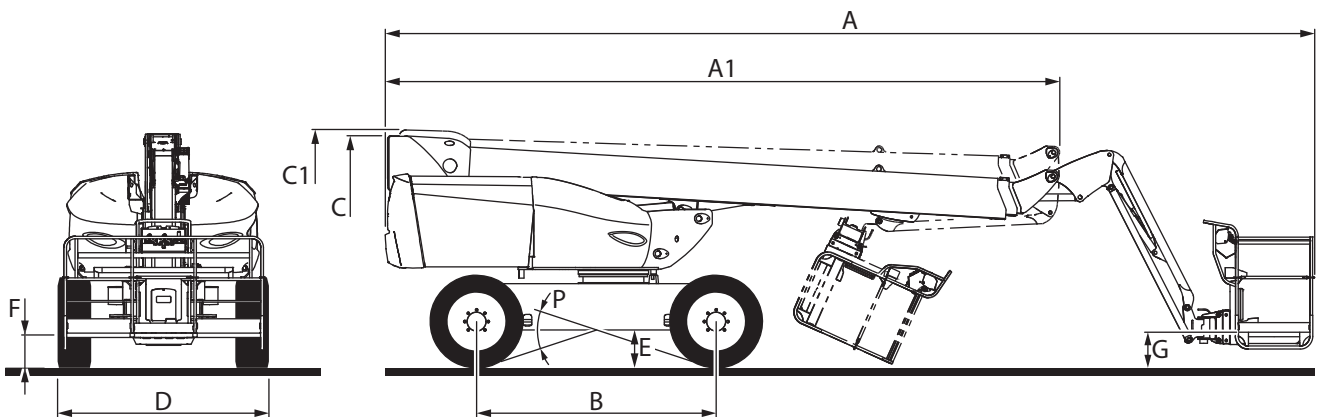
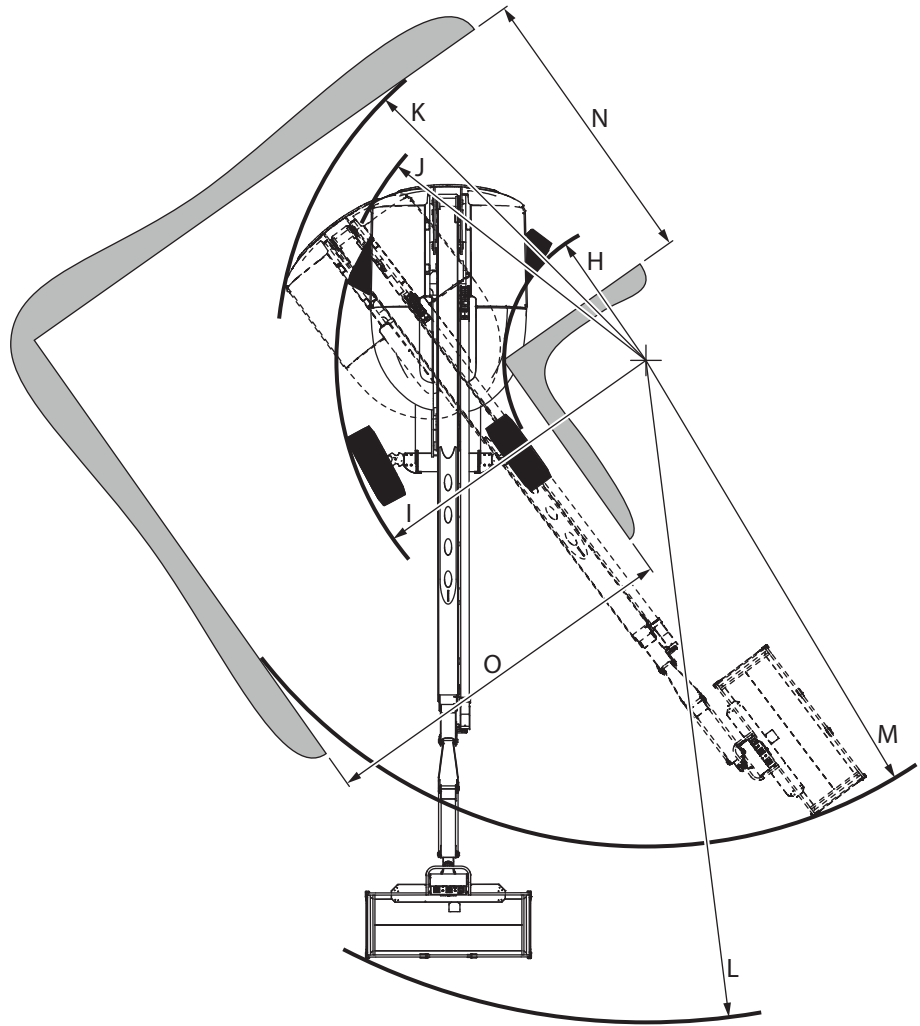

D1	mm	19202	
H1	mm	2,798 (1)	2,785 (2)
D2	mm	8285	
H2	mm	23,909 (1)	23,890 (2)
H3	mm	180 (1)	195 (2)

(1): Wheels SOLIDEAL HAULER-SKS (first version).
(2): Wheels SOLIDEAL SOLIDAIR AWP (second version).

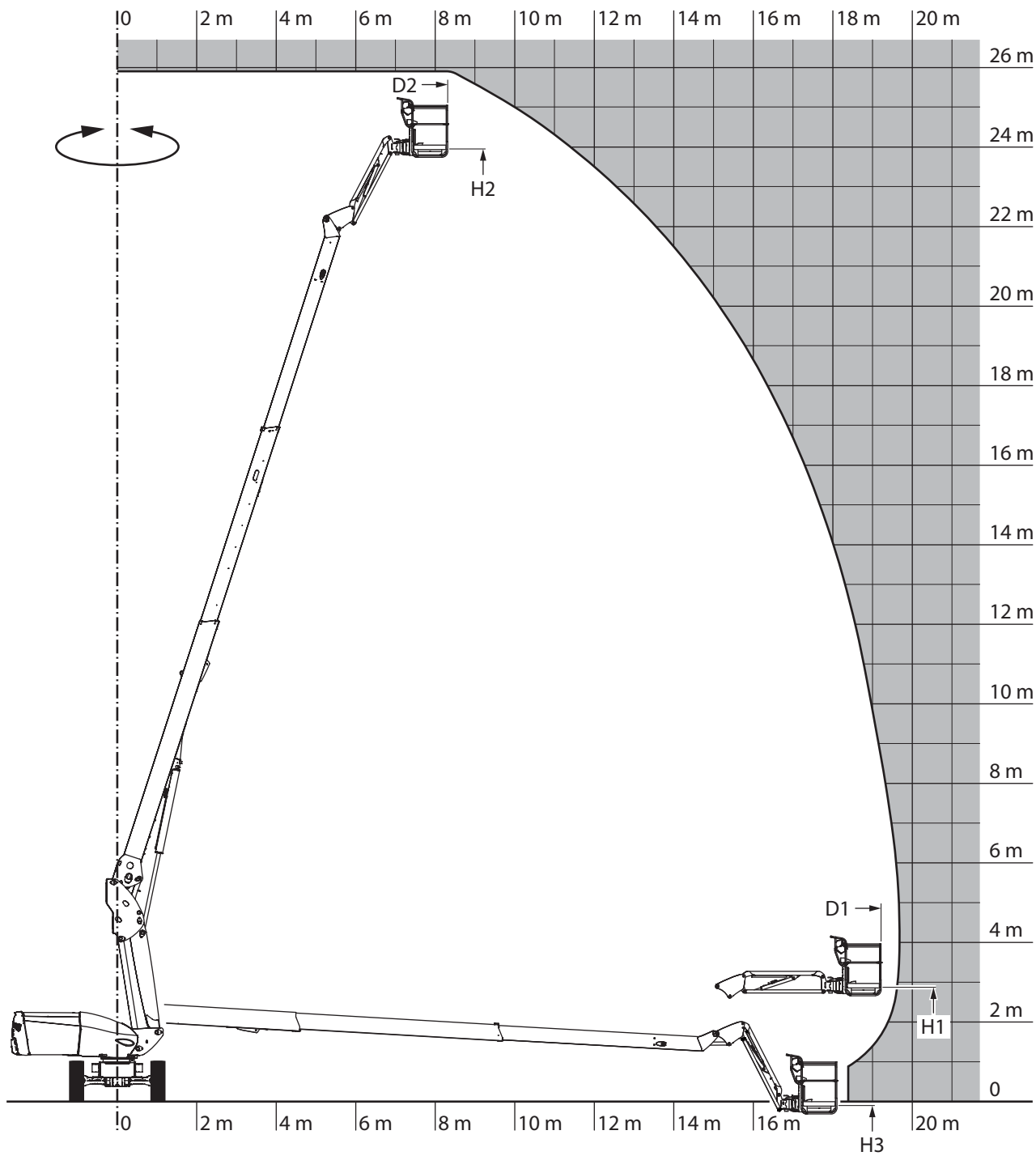

DIMENSIONS AND DIAGRAM 280TJ

A	mm	11355	
A1	mm	8095	
B	mm	2800	
C	mm	2,750 (1)	2,730 (2)
C1	mm	2,725 (1)	2,710 (2)
D	mm	2,430 (1)	2,480 (2)
E	mm	430 (1)	415 (2)
F	mm	375 (1)	355 (2)
G	mm	500 (1)	485 (2)

H	mm	2,000 (1)	1,975 (2)
I	mm	4,330 (1)	4,355 (2)
J	mm	4420	
K	mm	5180	
L	mm	9750	
M	mm	7340	
N	mm	4,030 (1)	4,000 (2)
O	mm	5,710 (1)	5,730 (2)
P	°/%	39 / 80 (1)	36 / 73 (2)

(1): Wheels SOLIDEAL HAULER-SKS (first version).

(2): Wheels SOLIDEAL SOLIDAIR AWP (second version).

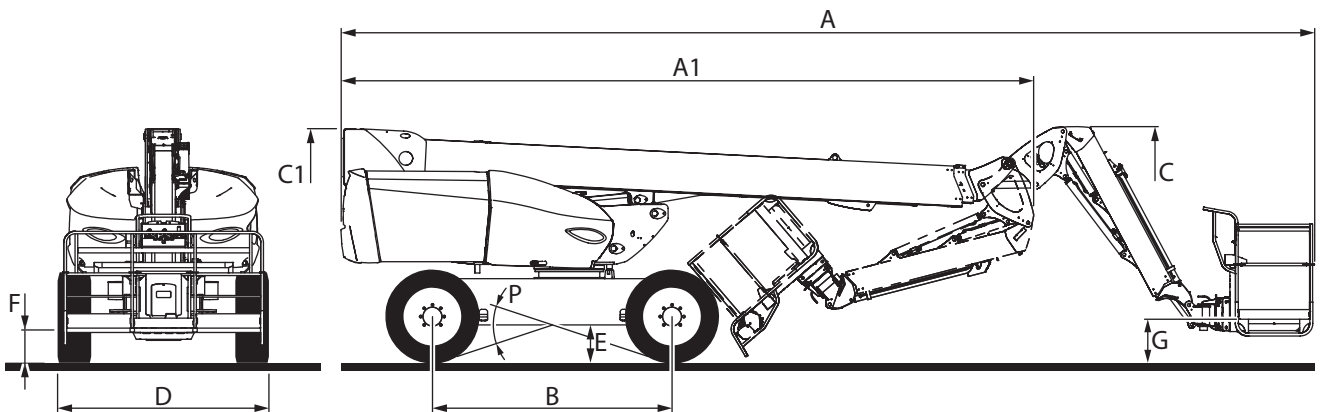
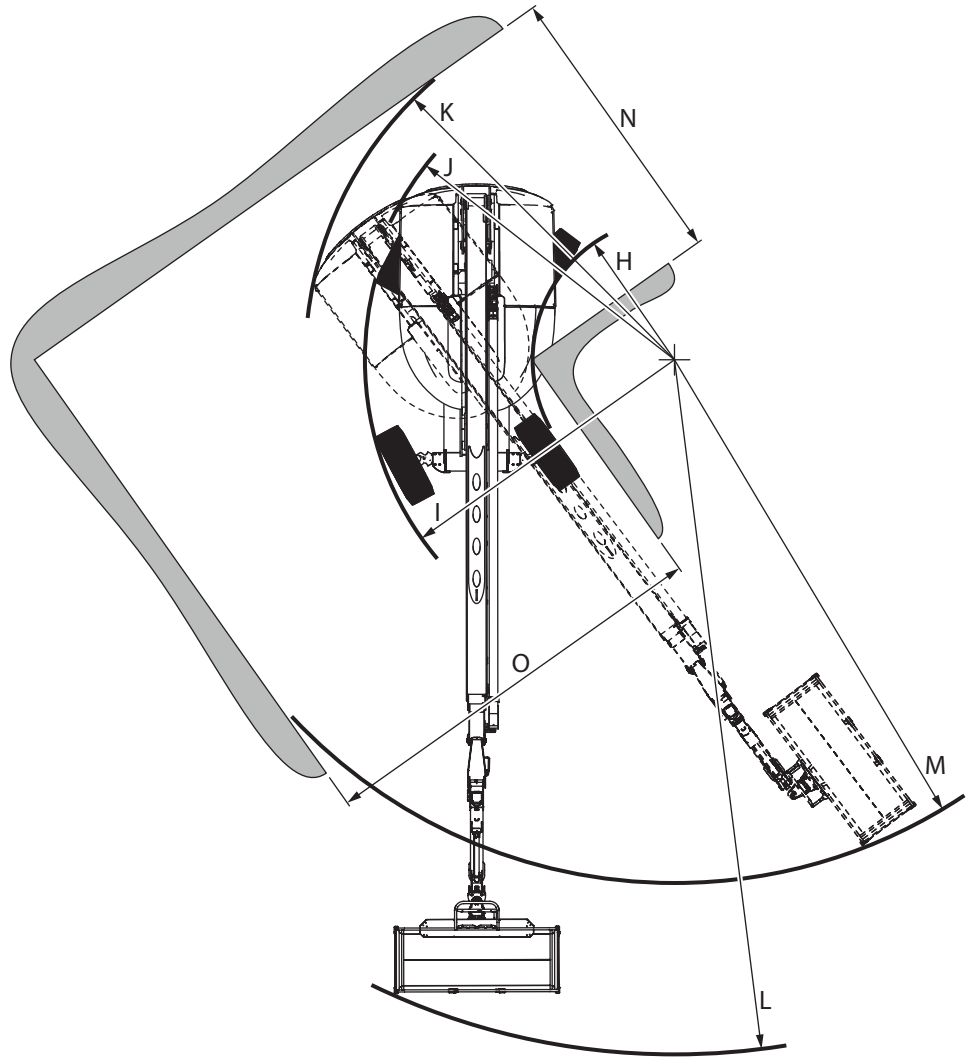

D1	mm	20950	
H1	mm	3,050 (1)	3,035 (2)
D2	mm	9100	
H2	mm	25,750 (1)	25,735 (2)
D3	mm	18950	
H3	mm	1,150 (1)	1,165 (2)

(1): Wheels SOLIDEAL HAULER-SKS (first version).

(2): Wheels SOLIDEAL SOLIDAIR AWP (second version).

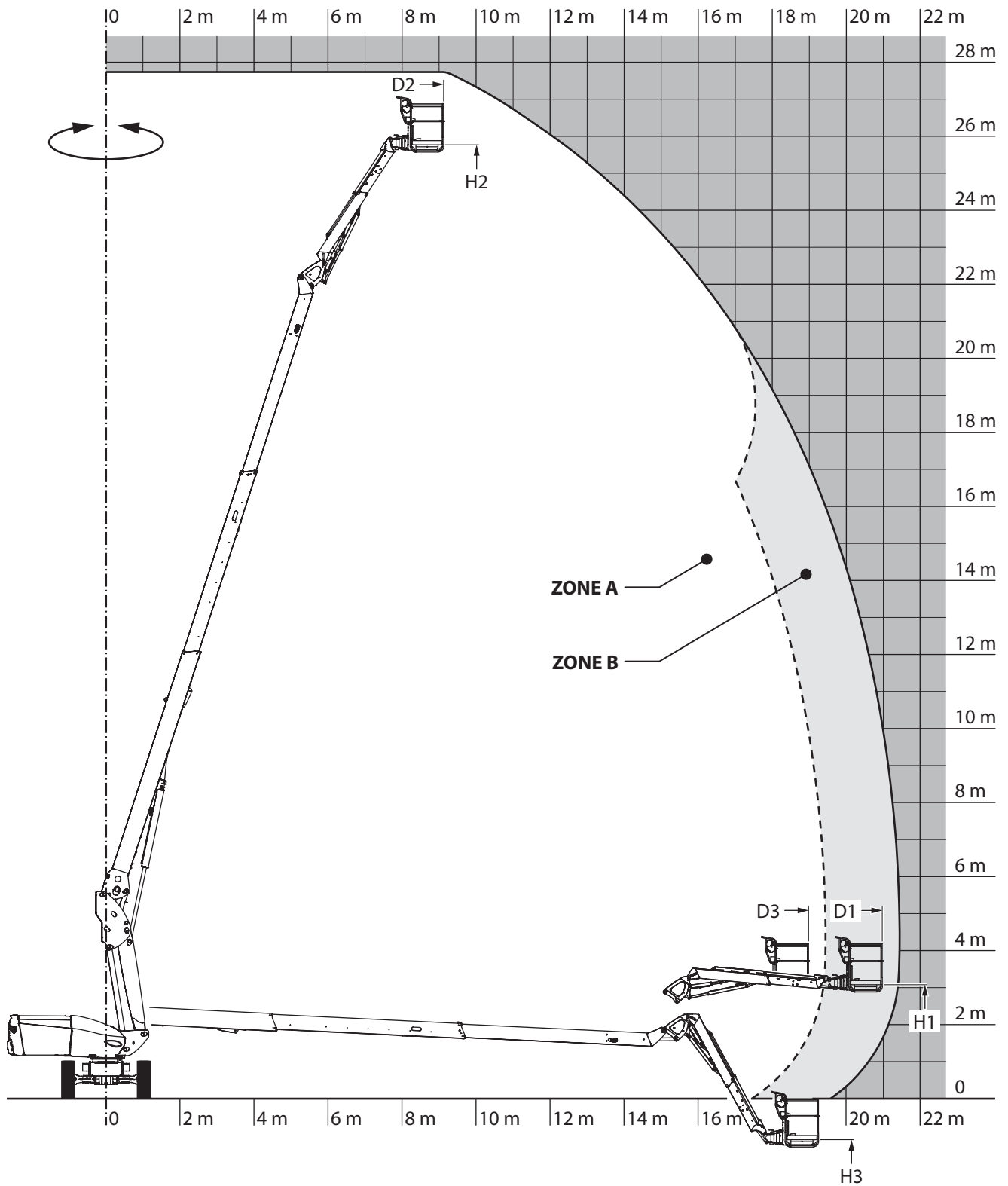

LOAD SPECIFICATIONS		ZONE A	ZONE B	±
Platform				
- Maximum capacity of basket	kg (lbs)	350 (771)	240 (529)	-
- Maximum number of people in the basket (indoor use/ outdoor use)		3/3	2/2	-

647382 (01/12/2018)
260/280 TJ

SAFETY COMPONENTS

GUARDRAIL

⚠ IMPORTANT ⚠

Do not attach the guardrail with a clamp, twine or any device that could prevent it from functioning properly.

- Raise the guardrail and keep it raised to get in and out of the basket.

NOTE: 1 guardrail at the rear of the basket, and 2 other guardrails on each side of the basket.

NOTE: The machine in the illustration is a 260 TJ

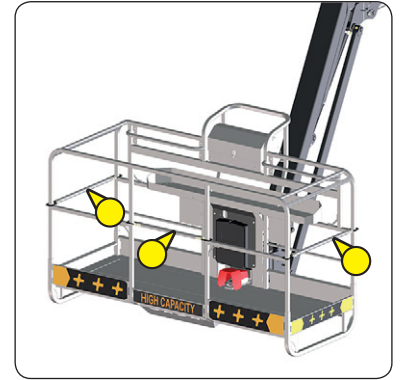

HARNESS ATTACHMENT POINTS

⚠ IMPORTANT ⚠

Only one operator is permitted to use each attachment point.

- Attach security harnesses to attachment points in the basket.

NOTE: 4 attachment points, STICKERS: HARNESS ATTACHMENT POINTS.

NOTE: The machine in the illustration is a 260 TJ

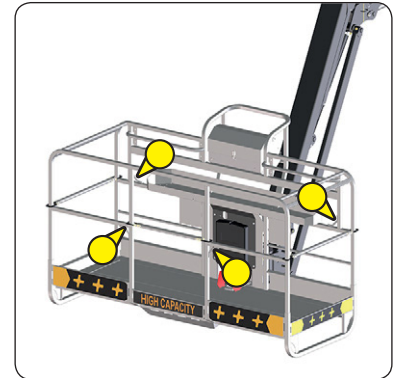

TURNTABLE LOCKING PIN

Position 1A: The turntable is unlocked.

Position 1B: The turntable is locked.

- Lock the turntable rotation when the platform is transported by a truck or other means of transport.
- Unlock the turntable rotation before using the platform.

LOCK THE TURNTABLE

- Align the pin 1 and the chassis A notch.
- Pull the pin and turn it a quarter turn to the left.
- Push it into the chassis notch (position 1B).

UNLOCK THE TURNTABLE

- Pull the pin 1 and turn it a quarter turn to the right.
- Push it into position 1A.

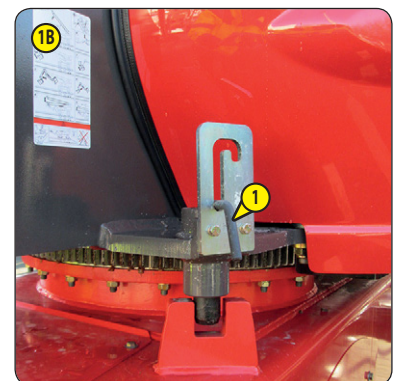
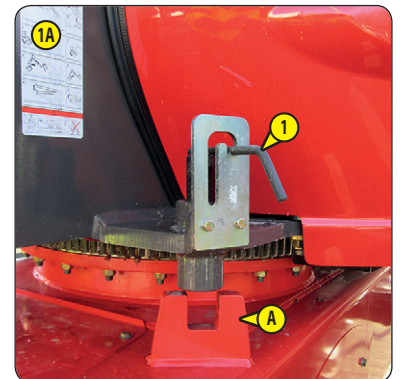

CONTROL PANEL AND SAFETY DEVICES AT GROUND LEVEL

⚠ IMPORTANT ⚠

The left and right are defined in OPERATING THE PLATFORM: TRANSPORT/WORKING POSITION.

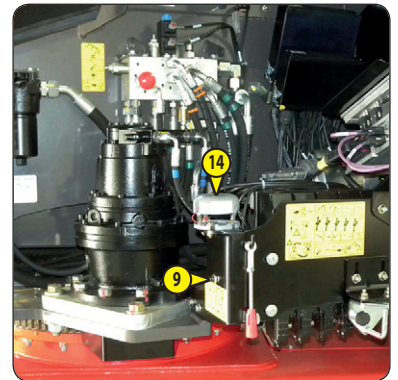
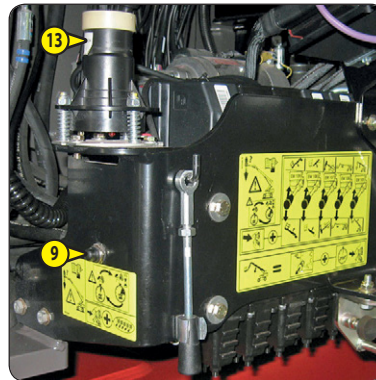
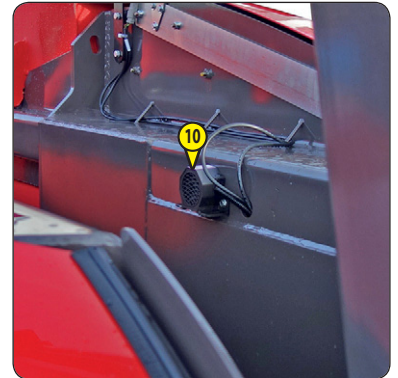
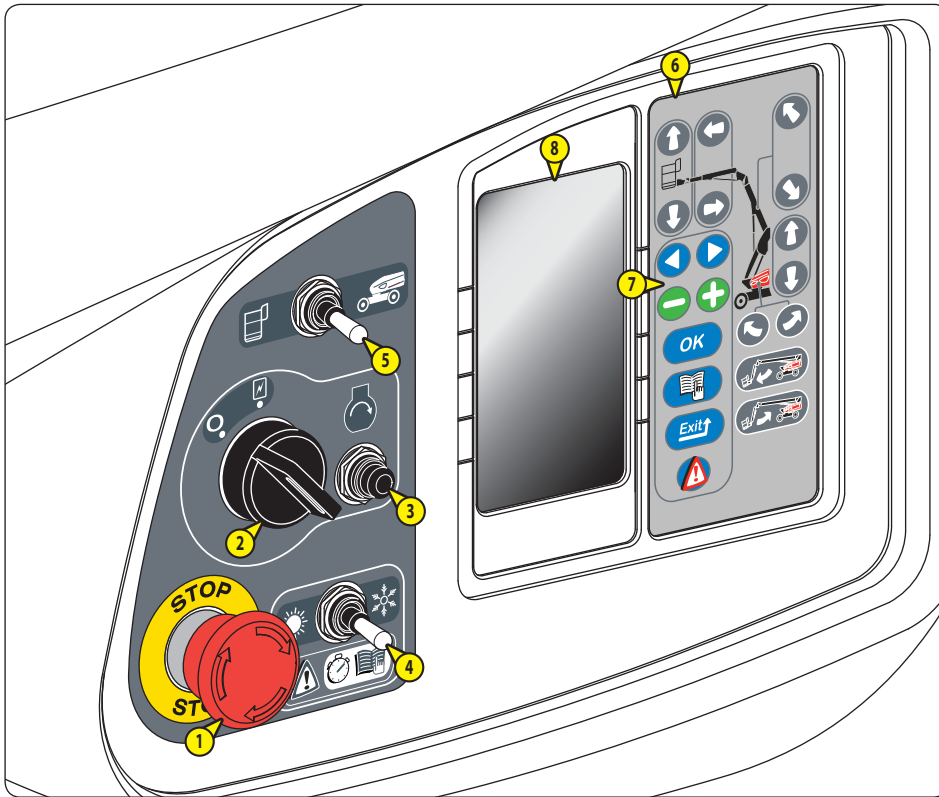

1 - EMERGENCY STOP BUTTON	2-34
2 - IGNITION SWITCH	2-34
3 - ENGINE STARTER BUTTON	2-34
4 - ENGINE STARTING MODE SWITCH	2-34
5 - CONTROL SELECTION SWITCH ON THE GROUND/IN THE BASKET	2-35
6 - CONTROL KEYS	2-35
7 - NAVIGATION SCREEN INTERFACE KEYS	2-35
8 - INTERFACE SCREEN	2-36
9 - BACKUP PUMP BUTTON	2-36
10 - HORN	2-36
11 - ORANGE ROTATING BEACON LIGHT	2-37
12 - BLUE FLASHING LIGHT (OPTION: "SAFEMANSYSTEM")	2-37
13 - LEVELLING SENSOR (first version)	2-37
14 - LEVELLING SENSOR (second version)	2-37

CONTROL PANEL AND SAFETY DEVICES IN THE BASKET

⚠ IMPORTANT ⚠

The front, rear, left and right are defined in OPERATING THE PLATFORM: TRANSPORT/WORKING POSITION.

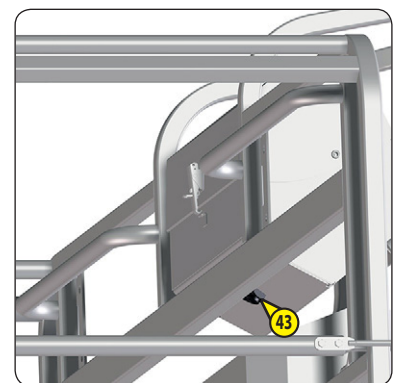
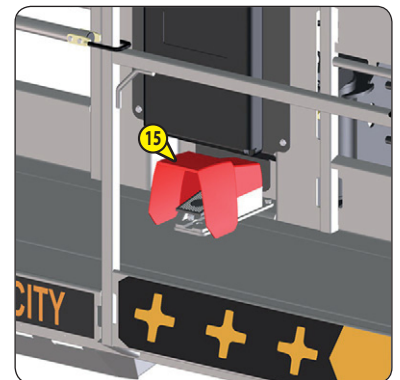
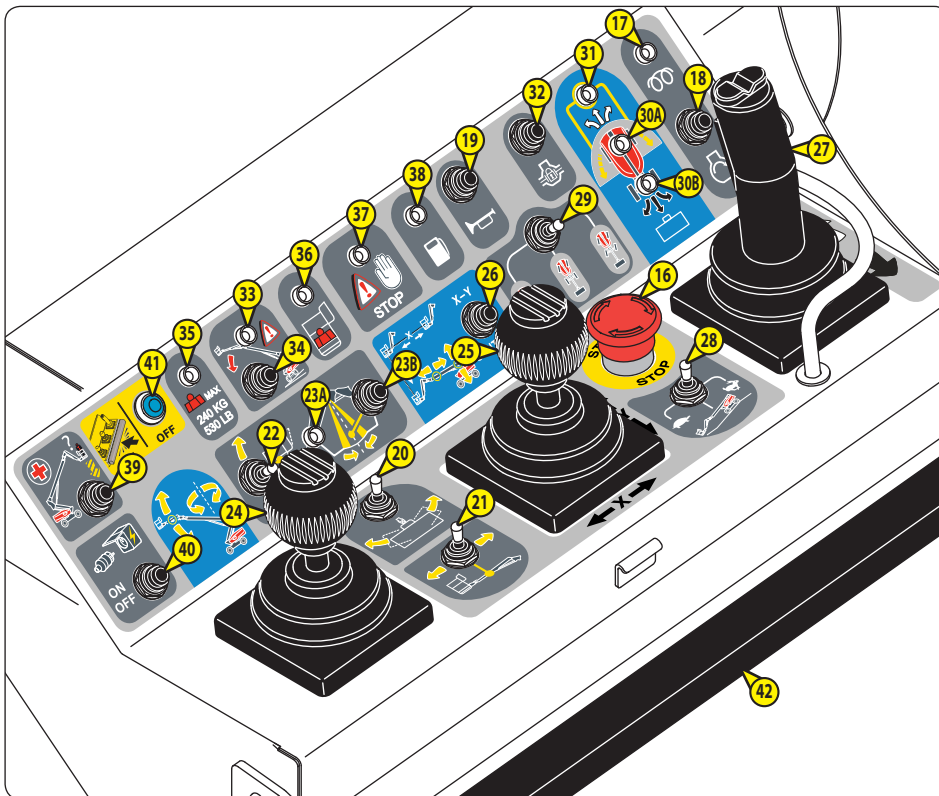

15 - PEDAL SWITCH	2-37
16 - EMERGENCY STOP BUTTON.....	2-38
17 - PREHEAT INDICATOR LAMP	2-38
18 - ENGINE STARTER BUTTON	2-38
19 - HORN BUTTON	2-38
20 - BASKET ROTATION SWITCH	2-39
21 - JIB TELESCOPE SWITCH ONLY FOR 280 TJ	2-39
22 - BASKET TILT SWITCH ONLY FOR 280 TJ	2-39
23 - JIB ZERO POSITION WARNING LIGHT AND BUTTON.....	2-40
24 - JIB AND TURNTABLE CONTROL HANDLE	2-40
25 - MAIN JIB AND TELESCOPE CONTROL HANDLE.....	2-41
26 - X-Y FUNCTION BUTTON	2-41
27 - DRIVING/STEERING CONTROL HANDLE.....	2-42
28 - DRIVING SPEED SELECTION SWITCH.....	2-42
29 - STEERING MODE SELECTION SWITCH.....	2-43
30 - WHEEL ALIGNMENT INDICATOR LIGHTS	2-43
31 - TURNTABLE ORIENTATION MORE THAN 90° INDICATOR LIGHT.....	2-44
32 - DIFFERENTIAL LOCKING BUTTON	2-44
33 - TILTING/OSCILLATION ALARM LIGHT	2-45
34 - USE ON SLOPE BUTTON	2-45
35 - RESTRICTED CAPACITY WARNING LIGHT ONLY FOR 280 TJ	2-46
36 - OVERLOAD ALARM LIGHT	2-46
37 - FAULT ALARM INDICATOR LIGHT	2-47
38 - LOW FUEL LEVEL ALARM LIGHT	2-48
39 - BACKUP PUMP BUTTON	2-48
40 - GENERATOR BUTTON (OPTION: GENERATOR)	2-48
41 - RESET BUTTON (OPTION: "SAFEMANSYSTEM").....	2-49
42 - PRESSURE SENSITIVE BAR (OPTION: "SAFEMANSYSTEM").....	2-49
43 - AUDIBLE ALARM.....	2-49

REMOTE CONTROL UNIT

The remote control unit **A** is located under the turntable's right-hand cover.



FIRST VERSION

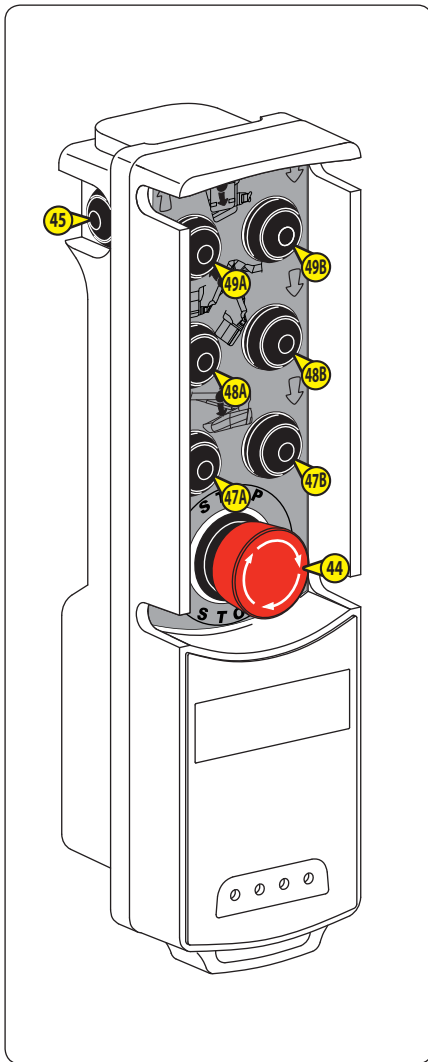

SECOND VERSION

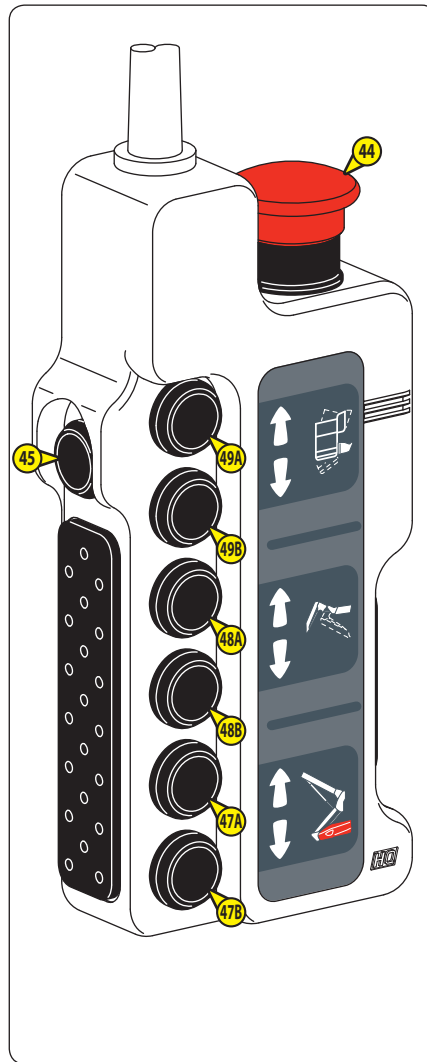

THIRD VERSION

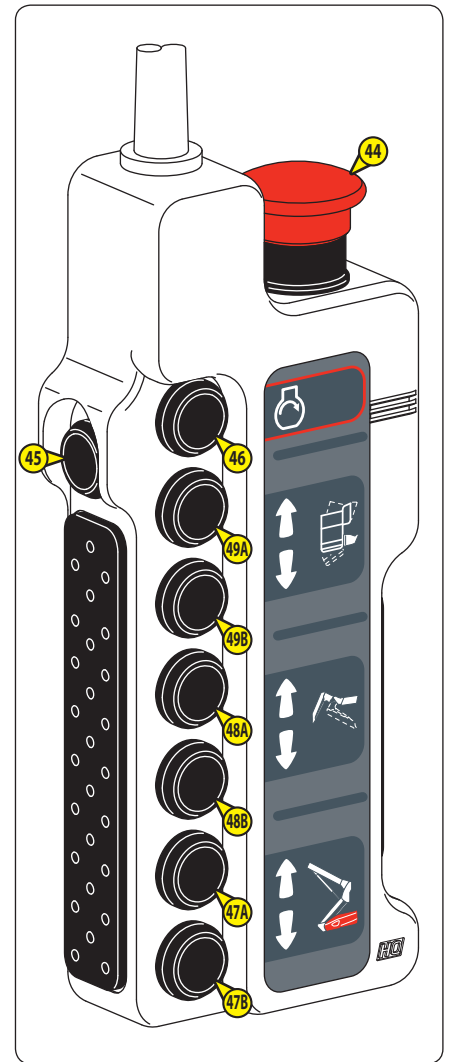

44 - EMERGENCY STOP BUTTON.....	2-50
45 - ACTIVATION BUTTON	2-50
46 - ENGINE STARTER BUTTON DEPENDING ON VERSION	2-51
47 - MAIN JIB CONTROL BUTTONS.....	2-51
48 - BASKET/JIB TILT CONTROL BUTTONS.....	2-51
49 - BASKET TILT BUTTON ONLY FOR 280 TJ	2-52

1 - EMERGENCY STOP BUTTON

⚠ IMPORTANT ⚠

In all cases this control takes priority, even when the movements are executed from the basket control panel or the remote control unit.

Movements may stop suddenly if the emergency stop is activated.

2 positions:

- OFF (locked): Press the button to cut off movement and to stop the engine.
- ON position (unlocked): Turn the button a quarter turn to the right and release it.

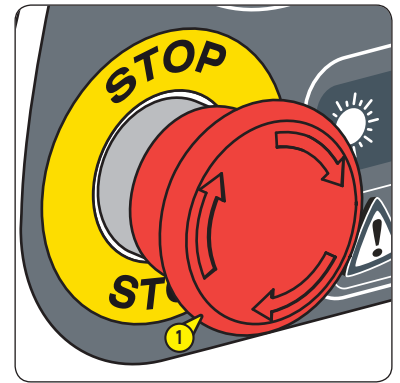

2 - IGNITION SWITCH

2 positions:

 Power down platform and stop engine. The key can be removed.

 Power up platform and start the engine preheat cycle. The key cannot be removed.

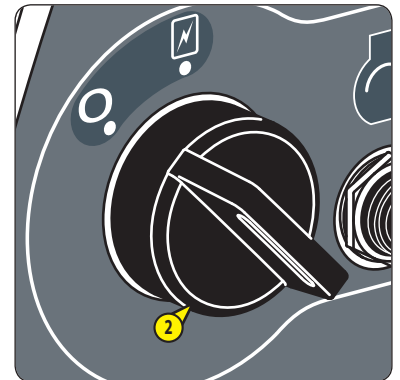

3 - ENGINE STARTER BUTTON

⚠ IMPORTANT ⚠

Do not keep the button pressed for more than 15 seconds.

- Press and hold down the button to start the engine.
- Release button once the engine has started.

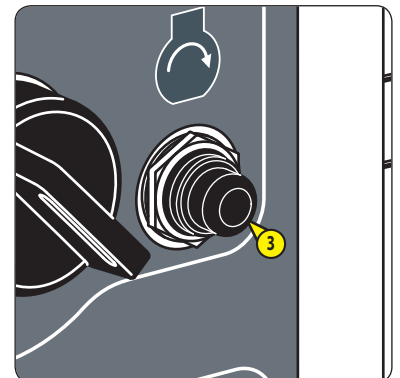

4 - ENGINE STARTING MODE SWITCH

2 positions:

 SUN POSITION: For an outside temperature higher than -10 °C.

 SNOW POSITION: For an outside temperature lower than -10 °C:

- Put the switch on the SNOW POSITION.
- Switch on the engine.
- Wait for 30 to 60 seconds depending on the outside temperature without using the platform controls.
- Put the switch on the SUN POSITION to restore standard idling.

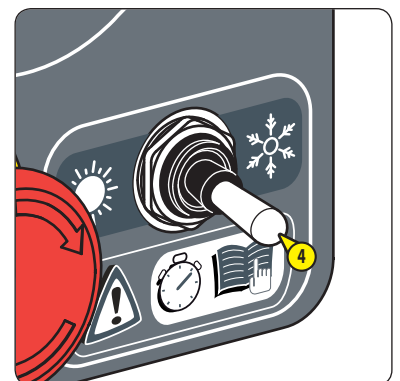

5 - CONTROL SELECTION SWITCH ON THE GROUND/IN THE BASKET

2 positions:



CONTROLS IN THE BASKET when the switch is released:

- The controls in the basket are activated.



GROUND CONTROLS:

- Push and hold the switch to the right to activate the ground level controls.

NOTE: This operating mode is called the "dead man" function.



6 - CONTROL KEYS

- Push and hold the ground level/basket control selection switch to the right
- Press and hold down the appropriate keys to activate platform controls:



- A RAISE THE JIB.**
- B LOWER THE JIB.**
- C EXTEND THE JIB TELESCOPE (ONLY FOR 280 TJ).**
- D RETRACT THE JIB TELESCOPE (ONLY FOR 280 TJ).**
- E EXTEND THE TELESCOPE.**
- F RETRACT THE TELESCOPE.**
- G RAISE THE MAIN JIB.**
- H LOWER THE MAIN JIB.**
- I TURN THE TURNTABLE TO THE LEFT.**
- J TURN THE TURNTABLE TO THE RIGHT.**
- K TILT BASKET/JIB UPWARDS.***
- L TILT BASKET/JIB DOWNWARDS.***

*: These controls are only active when the angle of the main jib is 15° maximum in relation to the completely lowered position.

- Release the keys or the selection switch to stop.

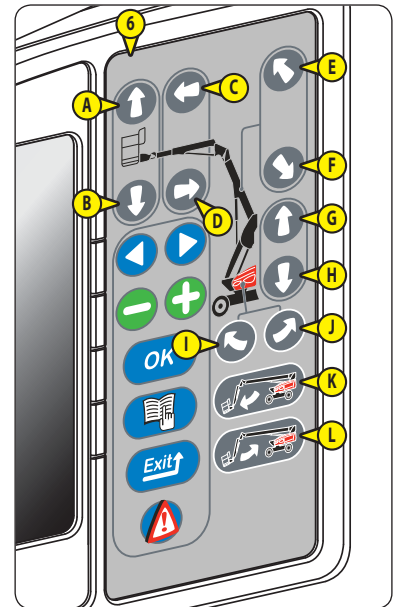

7 - NAVIGATION SCREEN INTERFACE KEYS

- Press the appropriate keys:



ARROWS:

- Navigate through the menu/sub-menu pages.



PLUS/MINUS:

- Navigate through the menu pages or change the parameters.



OK:

- Confirm a selection or a parameter.



MENU:

- Display the MENU PAGE.
- Exit a men/sub-menu and return to WORK PAGE.



EXIT:

- Cancel a parameter change.
- Return to the previous sub-menu level.



FAULT:

- Display the FAULT CODE/ALARM PAGE.

NOTE: SCREEN DISPLAY - DESCRIPTION OF PAGES.



8 - INTERFACE SCREEN

The interface screen displays all the start-up steps and the settings, and gives access to specific sub-menus, such as:

- Platform maintenance.
- Fault log.
- Hour meters (engine operation hours counter, daily usage hour counter, etc.).

NOTE: SCREEN DISPLAY - DESCRIPTION OF PAGES.



9 - BACKUP PUMP BUTTON

 RESCUE PROCEDURE.



10 - HORN

The horn sounds:

- When the horn button is pressed.
- Depending on version: twice when the machine is turned on without starting the engine in the next 10 seconds, SCREEN DISPLAY - DESCRIPTION OF PAGES: ALARM PAGE.

ALL MOVEMENTS ALARM option: This sounds intermittently when the controls are activated and when driving/steering the platform, SUB-MENU DEFINITIONS: USER OPTIONS: HORN MODE.

DRIVING/STEERING ALARM option: This sounds intermittently when driving/steering the platform, SUB-MENU DEFINITIONS: USER OPTIONS: HORN MODE.

Option "SafeManSystem": It sounds intermittently when the system is in alarm mode, OPTIONS.

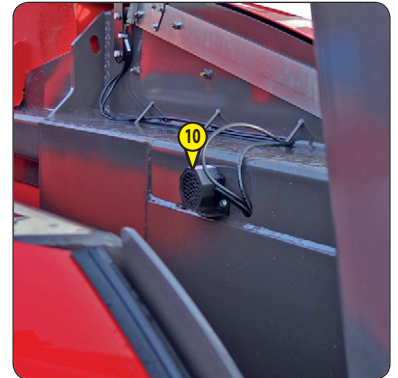

11 - ORANGE ROTATING BEACON LIGHT

PERMANENT ORANGE ROTATING BEACON LIGHT option deactivated: The orange rotating beacon light is lit when the controls are activated and when driving/steering the platform, SUB-MENU DEFINITIONS: USER OPTIONS: PERMANENT ORANGE ROTATING BEACON LIGHT.

PERMANENT ORANGE ROTATING BEACON LIGHT activated: The orange rotating beacon light is lit when the platform is powered up, SUB-MENU DEFINITIONS: USER OPTIONS: PERMANENT ORANGE ROTATING BEACON LIGHT.



12 - BLUE FLASHING LIGHT (OPTION: "SAFEMANSYSTEM")

 OPTIONS.

13 - LEVELLING SENSOR (first version)

Two indicator lights under the levelling sensor indicate its status:

	RED LIGHT	YELLOW LIGHT	AUDIBLE ALARM
Maximum authorised slope not reached	Lit	Unlit	Stop
Maximum authorised slope reached	Lit	Lit	Sounds intermittently

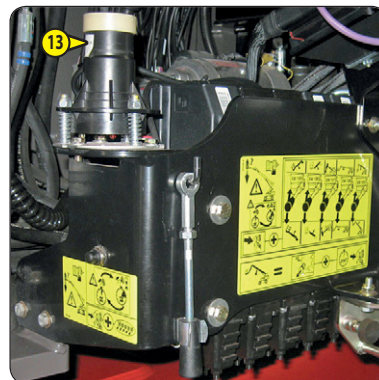

14 - LEVELLING SENSOR (second version)

An indicator light on the levelling sensor indicates its status:

	INDICATOR LIGHT	AUDIBLE ALARM
Maximum authorised slope not reached	Lit	Stop
Maximum authorised slope reached	Unlit	Sounds intermittently



15 - PEDAL SWITCH

⚠ IMPORTANT ⚠

Do not press the pedal switch when starting the engine.

- Press and hold down the foot switch to activate the controls from the basket control panel.

NOTE: This operating mode is called the "dead man" function.

NOTE: No controls can be activated if the foot switch is released.

NOTE: The machine in the illustration is a 260 TJ

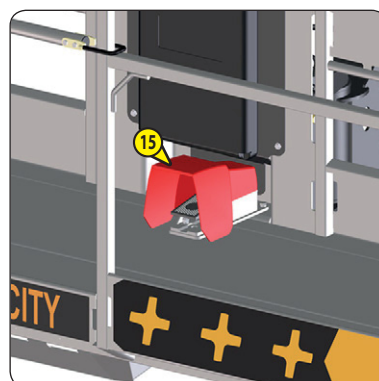

16 - EMERGENCY STOP BUTTON

⚠ IMPORTANT ⚠

Up to machine no. 950123 for 280 TJ: In all cases this control takes priority, even when the movements are executed from the ground control panel or the remote control unit.

For 260 TJ and from machine no. 950124 for 280 TJ: In all cases this control takes priority, except when the movements are executed from the ground control panel or the remote control unit.

Movements may stop suddenly if the emergency stop is activated.

2 positions:

- OFF (locked): Press the button to cut off movement and to stop the engine.
- ON position (unlocked): Turn the button a quarter turn to the right and release it.

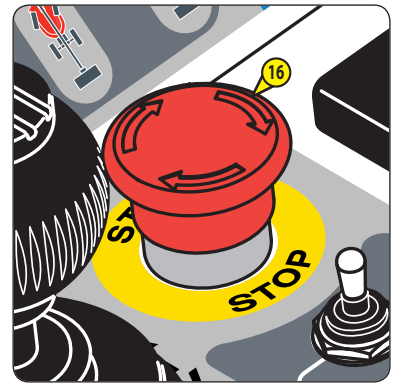

17 - PREHEAT INDICATOR LAMP

The indicator light is lit during the engine preheat cycle.

It switches off when the preheat cycle is completed.

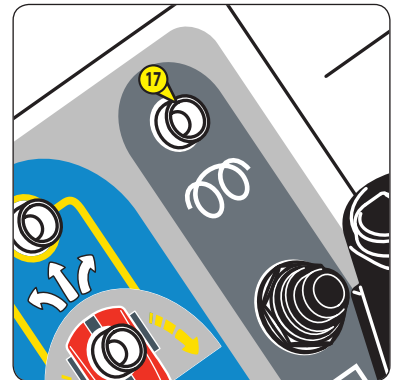

18 - ENGINE STARTER BUTTON

⚠ IMPORTANT ⚠

Do not keep the button pressed for more than 15 seconds.

- Press and hold down the button to start the engine.
- Release button once the engine has started.

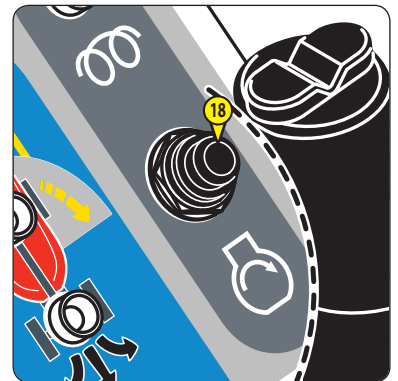

19 - HORN BUTTON

- Press and hold down the button to sound the horn. Release to stop it.



20 - BASKET ROTATION SWITCH

- Press and hold down the foot switch.

TURN BASKET TO THE LEFT

- Push and hold the switch to the left. Release to stop.

TURN BASKET TO THE RIGHT

- Push and hold the switch to the right. Release to stop.

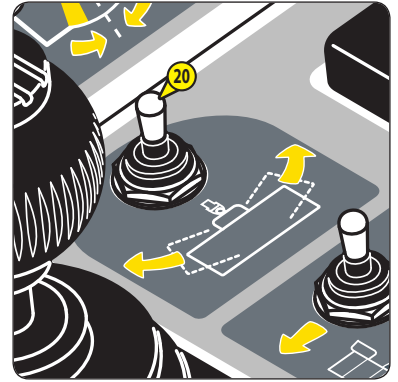

21 - JIB TELESCOPE SWITCH ONLY FOR 280 TJ

- Press and hold down the foot switch.

EXTEND THE JIB TELESCOPE

- Push and hold the switch to the left. Release to stop.

RETRACT THE JIB TELESCOPE

- Push and hold the switch to the right. Release to stop.



22 - BASKET TILT SWITCH ONLY FOR 280 TJ

- Press and hold down the foot switch.

TILT BASKET UPWARDS

- Push and hold the switch upwards. Release to stop.

TILT BASKET DOWN

- Push and hold the switch downwards. Release to stop.

NOTE: These controls are only active when the JIB ZERO POSITION WARNING LIGHT is off.

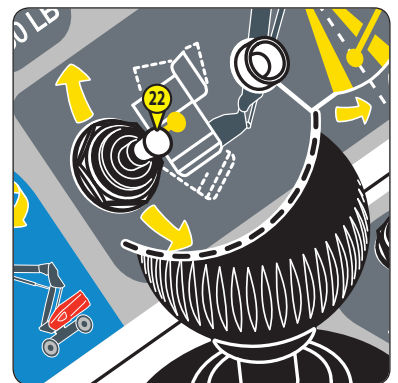

23 - JIB ZERO POSITION WARNING LIGHT AND BUTTON

⚠ IMPORTANT ⚠

⚠ **FAULT WARNING LIGHT** when the warning light **23A** flashes at the same time as the **FAULT WARNING LIGHT**.

The basket/jib tilt is given by the position of the gauge **A** in relation to the sticker **B** ⚠ **STICKER: JIB ANGLE**.

ALARM LIGHT **23A**

It is off when the basket/jib tilt is less than 5° (upwards or downwards).

It is on when the basket/jib tilt is greater than 5° and less than 9° (upwards or downwards).

It is necessary to return the basket/jib tilt to zero:

- Press and hold down the foot switch.
- Press and hold down button **23B**.
- Wait until the warning light goes off and then wait till the audible alarm sounds once.
- Release the button.

NOTE: ⚠ **STICKERS: JIB ZERO/X-Y/TURNTABLE ORIENTATION **C****.

It flashes when the basket/jib tilt is greater than 9° (upwards or downwards):

NOTE: The audible alarm sounds intermittently and all the controls are locked.

- Alert the person on the ground to activate the emergency controls and get out of the basket.
- If necessary, contact the maintenance personnel to unlock the controls.

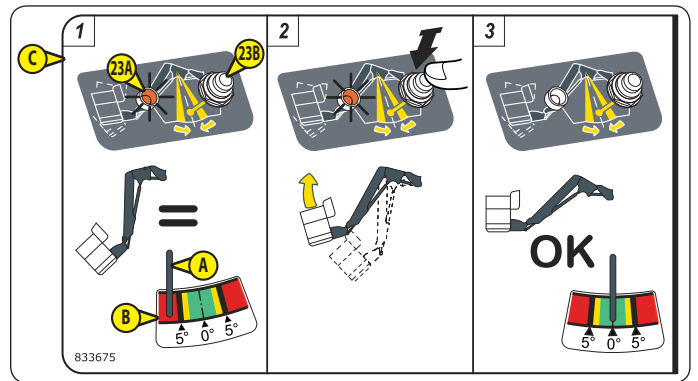
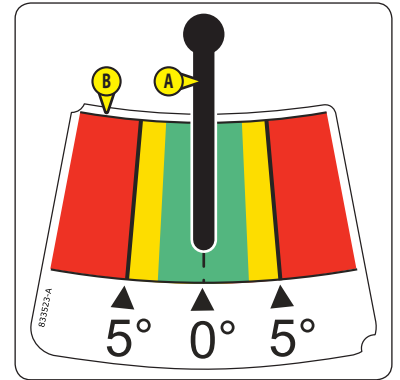

24 - JIB AND TURNTABLE CONTROL HANDLE

- Press and hold down the foot switch.

RAISE THE JIB

- Push and hold the control handle forward. Release to stop.

LOWER THE JIB

- Pull and hold the control handle back. Release to stop.

TURN THE TURNTABLE TO THE LEFT

- Push and hold the control handle to the left. Release to stop.

TURN THE TURNTABLE TO THE RIGHT

- Push and hold the control handle to the right. Release to stop.

NOTE: The proportional control handle must be operated smoothly, without jerking.

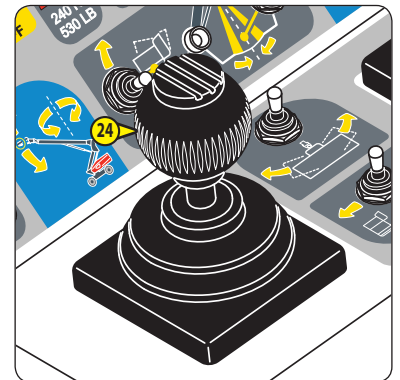

25 - MAIN JIB AND TELESCOPE CONTROL HANDLE

- Press and hold down the foot switch.

RAISE THE MAIN JIB

- Push and hold the control handle forward. Release to stop.

LOWER THE MAIN JIB

- Pull and hold the control handle back. Release to stop.

EXTEND THE TELESCOPE

- Push and hold the control handle to the left. Release to stop.

RETRACT THE TELESCOPE

- Push and hold the control handle to the right. Release to stop.

NOTE: The proportional control handle must be operated smoothly, without jerking.

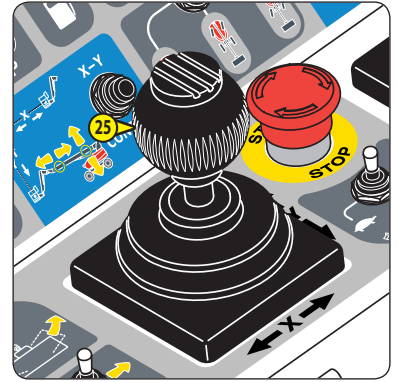

26 - X-Y FUNCTION BUTTON

- Press and hold down the foot switch.
- Press and hold down button .

NOTE: The audible alarm sounds intermittently when the button is pressed.

X FUNCTION

To keep a constant distance between the basket and a ceiling when extending or retracting the telescope.

- Push and hold down the control handle (25) to the left or right. Release to stop.
- Release the button.

NOTE: STICKERS: JIB ZERO/X-Y/TURNTABLE ORIENTATION (A).

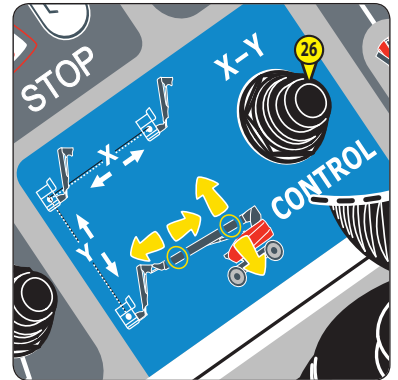

FUNCTION Y

To keep a constant distance between the basket and a wall when raising or lowering the main jib.

- Push and hold down the control handle (25) upwards or downwards. Release to stop.
- Release the button.

NOTE: STICKERS: JIB ZERO/X-Y/TURNTABLE ORIENTATION (A).

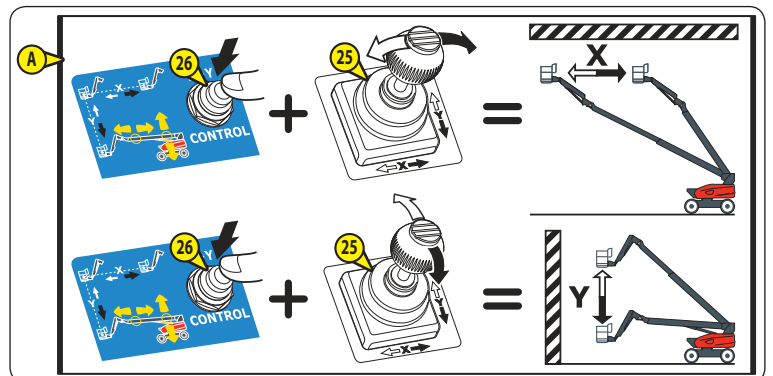

27 - DRIVING/STEERING CONTROL HANDLE

⚠ IMPORTANT ⚠

Always refer to the arrow colours on the chassis and on the control panel in the basket before driving/steering the platform.

- Press and hold down the foot switch. Press and hold down the **A** trigger.

NOTE: The driving/steering controls cannot be activated if the trigger and/or the pedal switch are released.

DRIVE FORWARDS

- Push and hold the control handle forward. Release to brake.

DRIVE BACKWARDS

- Pull and hold the control handle back. Release to brake.

BRAKE

- Release the control handle in the neutral position to action the brakes.

NOTE: The brakes are also actioned when the trigger and/or the pedal switch are released.

STEER TO THE LEFT

- Press and hold down button **B**. Release to stop.

STEER TO THE RIGHT

- Press and hold down button **C**. Release to stop.

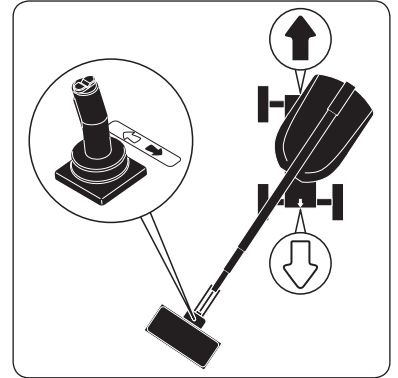
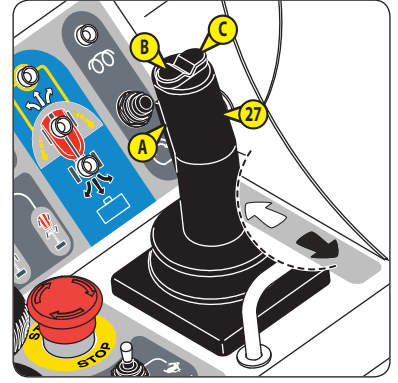

28 - DRIVING SPEED SELECTION SWITCH

⚠ IMPORTANT ⚠

Always brake the platform before selecting the driving speed.

3 positions:



TORTOISE speed for driving the platform at slow speed.



RAMP speed for driving the platform at slow speed with full power.



HARE speed for driving the platform at high speed.

NOTE: Driving speed selection only works in the transport position, ◀ OPERATING THE PLATFORM: TRANSPORT/WORKING POSITION.

NOTE: Depending on conditions, restrictions may apply to the speed activated, ◀ OPERATING THE PLATFORM: TRANSPORT/WORKING POSITION.

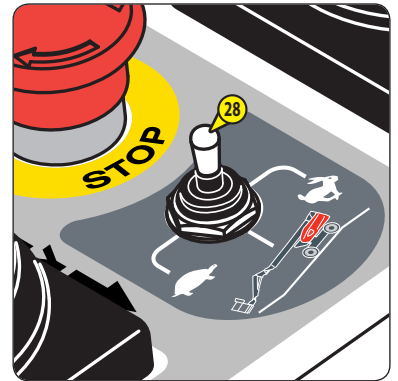

29 - STEERING MODE SELECTION SWITCH

⚠ IMPORTANT ⚠

The front and rear wheels must be correctly aligned with the platform axis before changing the steering mode,

⚠ WHEEL ALIGNMENT INDICATOR LIGHT. If the wheels are not correctly aligned:

- Select the 4-WHEEL DRIVE steering mode and align the rear wheels.
- Select the 2-WHEEL DRIVE steering mode and align the front wheels.

3 positions:



4-WHEEL DRIVE steering mode: Front and rear steering wheels in opposite directions.



2-WHEEL DRIVE steering mode: Front steering wheels.



CRAB steering mode: Front and rear steering wheels in the same direction.

NOTE: Depending on conditions, restrictions may apply to the speed activated,

⚠ OPERATING THE PLATFORM: TRANSPORT/WORKING POSITION.



30 - WHEEL ALIGNMENT INDICATOR LIGHTS

The Indicator light **30A** comes on when the front wheels are correctly aligned with the platform axis.

The indicator light **30B** is on when the rear wheels are correctly aligned with the platform axis.

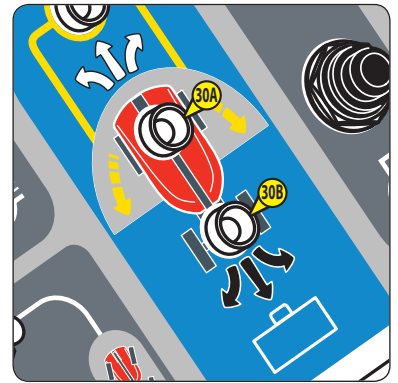

31 - TURNTABLE ORIENTATION MORE THAN 90° INDICATOR LIGHT

⚠ IMPORTANT ⚠

Always refer to the arrow colours on the chassis and on the control panel in the basket before driving/steering the platform.

The indicator light is off when the turntable angle is less than 90° (to left or right) in relation to the neutral position. The direction of travel is that indicated in the illustrations **A1** and **A2**.

The indicator light is on when the turntable angle is greater than 90° (to left or right) in relation to the neutral position (grey area **C**). The direction of travel is that indicated in the illustrations **B1** and **B2**.

NOTE:  STICKERS: JIB ZERO/X-Y/TURNTABLE ORIENTATION **D**.

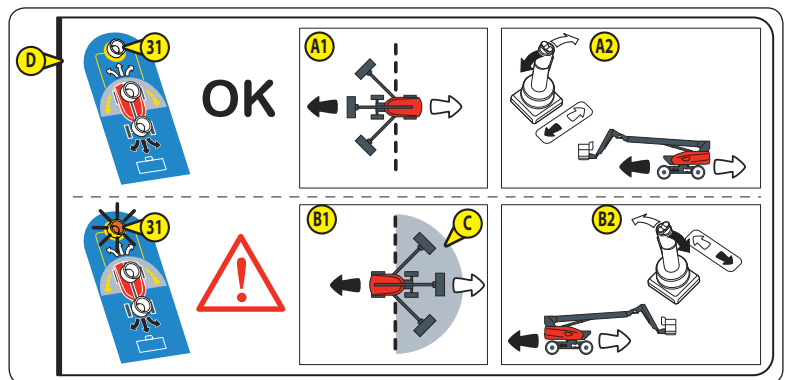
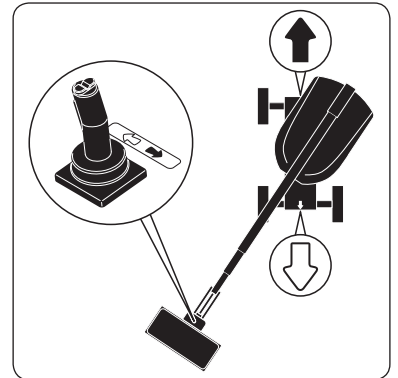
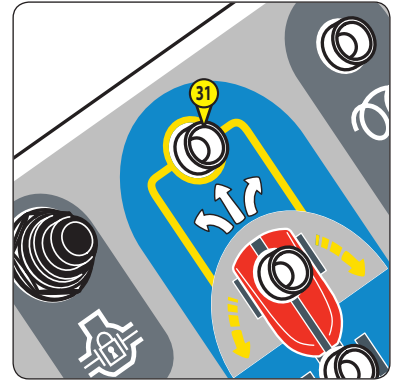

32 - DIFFERENTIAL LOCKING BUTTON

⚠ IMPORTANT ⚠

It is recommended that differential locking is only used when the wheels are correctly aligned with the platform axis.

- Press and hold down the button to activate the differential locking when the platform is being driven.
- Release the button and brake the platform to deactivate the differential locking.

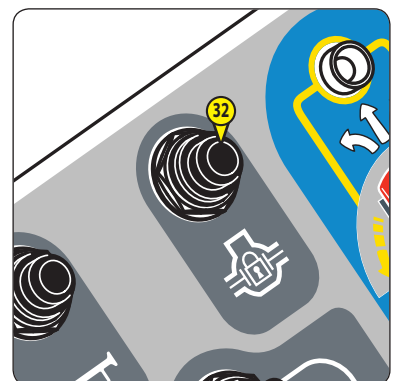

33 - TILTING/OSCILLATION ALARM LIGHT

The tilt alarm is activated when the platform is on a steep slope:

- The indicator light flashes (On = 0.6 seconds, Off = 0.4 seconds) and the audible alarm sounds intermittently (On = 1 seconds, Off = 1 seconds).
- Some controls are locked, OPERATING THE PLATFORM: LOCKED CONTROLS.

To stop the levelling alarm and unlock the controls:

- Fully retract the telescope.
- Retract the jib telescope completely (only for 280 TJ).
- Fully lower the main jib.
- Move platform to a level surface.

For 260 TJ and from machine no. 950124 for 280 TJ:

The oscillation alarm is activated when an oscillating axle locking fault is detected:

⚠ IMPORTANT ⚠

If the fault persists, consult your dealer.

- The indicator light flashes (On = 0.4 seconds, Off = 0.2 seconds) and the audible alarm sounds intermittently (On = 0.4 seconds, Off = 0.4 seconds).
- Some controls are locked, OPERATING THE PLATFORM: LOCKED CONTROLS.

To stop the oscillation alarm and unlock the controls:

- Fully retract the telescope.
- Retract the jib telescope completely (only for 280 TJ).
- Fully lower the main jib.
- Fully lower the jib.
- Move platform to a level surface.
- Press the key OK **OK** on the ground control panel so that the oscillation alarm is no longer displayed. This action is recorded in the faults history.

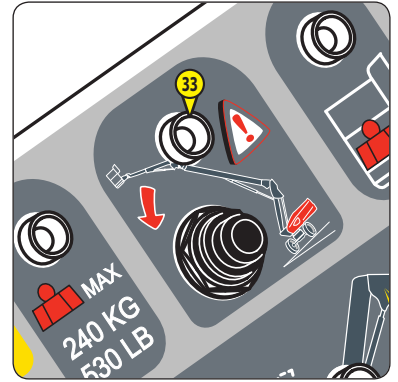

34 - USE ON SLOPE BUTTON

⚠ IMPORTANT ⚠

The platform could tip over when this function is used. Use with extreme caution.

- Press the button and hold it down to action the locked controls (except driving forward and backwards) when the tilt alarm is activated. TILT/OSCILLATION ALARM INDICATOR LIGHT.

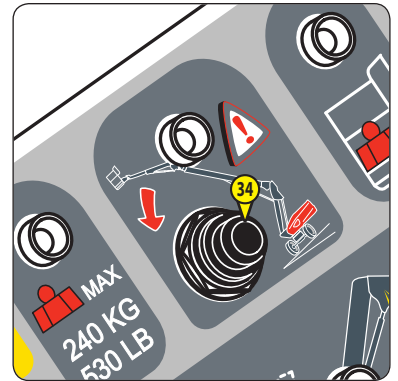

35 - RESTRICTED CAPACITY WARNING LIGHT ONLY FOR 280 TJ

The warning light status depends on the zone where the basket and the load in the basket are.



	LOAD IN THE BASKET	RESTRICTED CAPACITY WARNING LIGHT	
ZONE A (CAPACITY WITH NO RESTRICTIONS)	Less than 240 kg (529 lbs.)	Unlit	It is possible to reach ZONE B.
	More than 240 kg (529 lbs.)	Lit	It is not possible to reach ZONE B: The descent of the main jib is locked or the telescopic boom extension is locked.
ZONE B (CAPACITY WITH RESTRICTIONS)	Less than 240 kg (529 lbs.)	Flashes	The load in the basket is limited to 240 kg (529 lbs).
	More than 240 kg (529 lbs.)	Lit	The load in the basket has reached maximum capacity in this area. The OVERLOAD WARNING LIGHT flashes and the audible alarm sounds continuously.

NOTE: DIMENSIONS AND DIAGRAM 280 TJ for the definition of zones.

36 - OVERLOAD ALARM LIGHT

The overload alarm is activated when the load in the basket has reached maximum capacity:

- The light flashes and the audible warning sounds continuously.
- All controls are locked, OPERATING THE PLATFORM: LOCKED CONTROLS.

To stop the overload alarm and unlock the controls:

- Remove excessive load.



37 - FAULT ALARM INDICATOR LIGHT

⚠ IMPORTANT ⚠

Refer to the maintenance personnel if there is a fault.

The indicator light flashes when a fault is detected:

- Minor fault: on = 0.4 seconds, off = 0.8 seconds.
- Major fault: on = 0.4 seconds, off = 0.2 seconds.



MINOR FAULTS	AUDIBLE ALARM	
The pedal switch or control selection switch on the ground/ in the basket is blocked	1 beep	Stop using the machine.
The remote control unit activation button is locked		
The driving/steering control handle trigger is locked		
The pressure-sensitive bar is blocked (OPTION: "SAFEMANSYSTEM")		
Other minor faults	Stop	
MAJOR FAULTS	AUDIBLE ALARM	
CAN Communication	Stop	All the controls are locked
Low engine oil pressure	Sounds intermittently	Stop the engine immediately. NOTE: The engine stops after 90 seconds.
High coolant temperature		
Engine overspeed	Stop	The engine stops after 2 seconds.
Hydrostatic pump	Stop	The driving functions are locked.
Telescope cable slack or cut (CABLE BREAKAGE ALARM)	Sounds intermittently	Some controls are locked, \triangleleft OPERATING THE PLATFORM: LOCKED CONTROLS.
Proportional distributor	Sounds intermittently	Stop using the machine.
Overload sensor inconsistency		
Oscillating axle locked (1)		
Engine oil pressure sensor		
Arm angle sensor	Sounds intermittently	The simultaneous functions are locked. The movement speeds are reduced.
Arm angle sensor inconsistency		
Basket/jib tilt angle sensor (2)		
Inconsistency of the basket/jib tilt angle sensors (2)		
Telescope sensor inconsistency	Stop	
Fuel level very low (level 3)	\triangleleft LOW FUEL LEVEL ALARM LIGHT	

(1): For 260 TJ and from machine no. 950124 for 280 TJ, the LEVELLING/OSCILLATION ALARM LIGHT flashes at the same time.

(2): The JIB ZERO POSITION INDICATOR LIGHT flashes at the same time.

38 - LOW FUEL LEVEL ALARM LIGHT

The light flashes and the audible alarm sounds when the fuel level is low.



3 alarm levels:

	LOW FUEL LEVEL ALARM LIGHT	AUDIBLE ALARM
Level 1	On = 0.8 seconds Off = 0.4 seconds	3 beeps (ON = 0.6 seconds, OFF = 0.4 seconds) repeated every 10 minutes
Level 2	On = 0.4 seconds Off = 0.4 seconds	3 beeps (ON = 0.4 seconds, OFF = 0.4 seconds) repeated every minute
Level 3*	On = 0.3 seconds Off = 0.2 seconds	3 beeps (ON = 0.4 seconds, OFF = 0.4 seconds) repeated every 10 seconds

*: It is no longer possible to raise the main jib, extend the telescope, raise the jib, tilt the basket upwards/downwards, turn the turntable and turn the basket for more than 5 seconds at a time.

39 - BACKUP PUMP BUTTON

< RESCUE PROCEDURE.



40 - GENERATOR BUTTON (OPTION: GENERATOR)

< OPTIONS.



41 - RESET BUTTON (OPTION: "SAFEMANSYSTEM")

☞ OPTIONS.

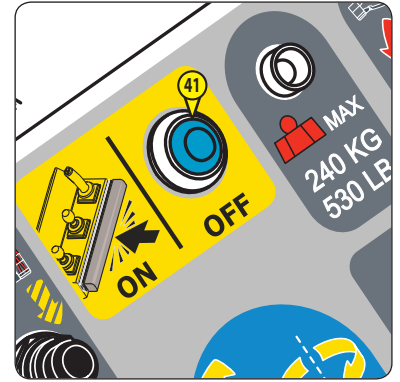

42 - PRESSURE SENSITIVE BAR (OPTION: "SAFEMANSYSTEM")

☞ OPTIONS.

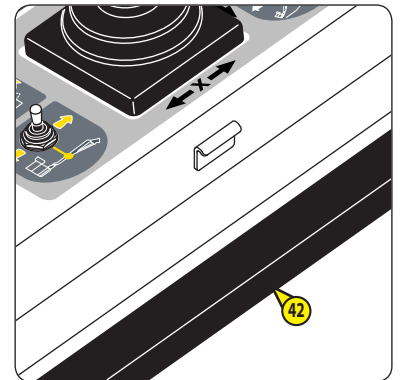

43 - AUDIBLE ALARM

The audible alarm sounds:

- Once after the platform has been powered up.
- Intermittently when the platform is on a steep slope, ☞ LEVELLING/OSCILLATION WARNING LIGHT.
- Intermittently when a locking fault in the oscillating axle is detected, ☞ LEVELLING/OSCILLATION WARNING LIGHT.
 - *: For 260 TJ and from machine no. 950124 for 280 TJ.
- Continuously when the basket load has reached maximum capacity, ☞ OVERLOAD ALARM INDICATOR LIGHT.
- When the fuel level is low, ☞ LOW FUEL LEVEL ALARM INDICATOR LIGHT.
- When a fault is detected, ☞ FAULT ALARM INDICATOR LIGHT.
- Twice when the controls cannot be operated simultaneously, ☞ OPERATING THE PLATFORM: SIMULTANEOUS CONTROLS.



44 - EMERGENCY STOP BUTTON

⚠ IMPORTANT ⚠

*In all cases this control takes priority, except when the movements are executed from the ground control panel.
Movements may stop suddenly if the emergency stop is activated.*

2 positions:

- OFF position (locked): Press the button to cut off movement and to stop the engine.
- Position ON (unlocked):
 - First and second version: Turn the button a quarter turn to the right and release it.
 - Third version: Pull the button or turn it a quarter turn to the right and release it.

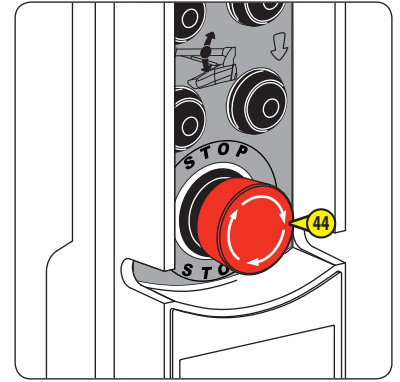

45 - ACTIVATION BUTTON

- Press and hold down the foot switch to activate the controls from the remote control unit.

NOTE: This operating mode is called "dead man" operating mode.

NOTE: No controls can be activated if the button is released.

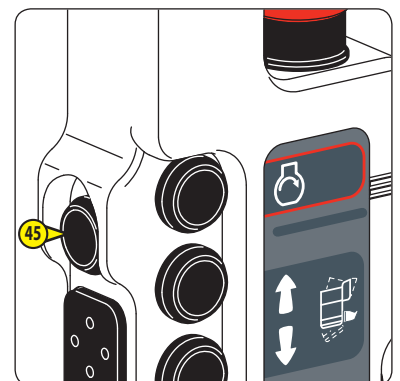
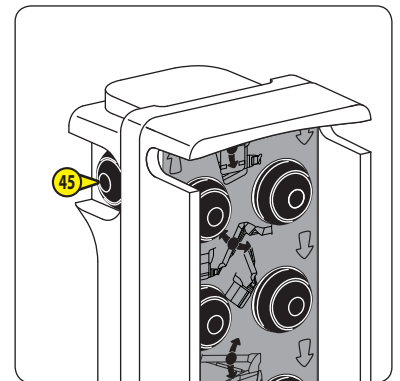

46 - ENGINE STARTER BUTTON DEPENDING ON VERSION

⚠ IMPORTANT ⚠

Do not keep the button pressed for more than 15 seconds.

- Press and hold down the activation button.
- Press and hold down the engine start button to start the engine.
- Release engine start button once the engine has started.
- Release activation button.

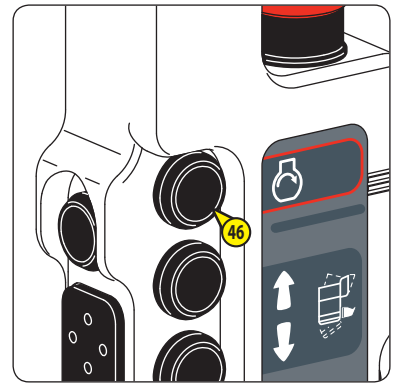

47 - MAIN JIB CONTROL BUTTONS

- Press and hold down the activation button.

RAISE THE MAIN JIB

- Press and hold down button **47A**. Release to stop.

LOWER THE MAIN JIB

- Press and hold down button **47B**. Release to stop.

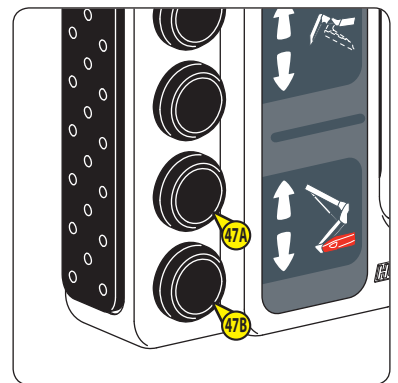
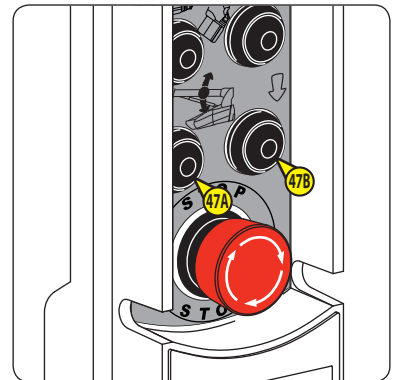

48 - BASKET/JIB TILT CONTROL BUTTONS

- Press and hold down the activation button.

TILT BASKET/JIB UP

- Press and hold down button **48A**. Release to stop.

TILT BASKET/JIB DOWN

- Press and hold down button **48B**. Release to stop.

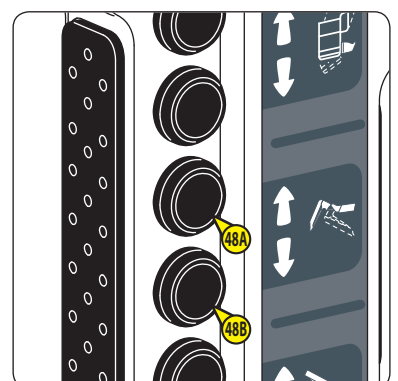
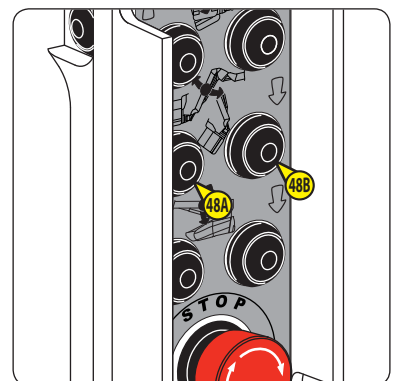

49 - BASKET TILT BUTTON ONLY FOR 280 TJ

- Press and hold down the foot switch.

TILT BASKET UPWARDS

- Press and hold down button **49A**. Release to stop.

TILT BASKET DOWN

- Press and hold down button **49B**. Release to stop.

NOTE: These controls are only active when the basket/jib tilt is less than 5° (upwards or downwards), refer to the position of the gauge **A** in relation to the sticker **B** ← STICKER: JIB ANGLE.

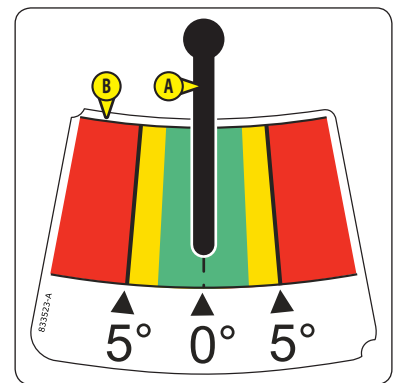
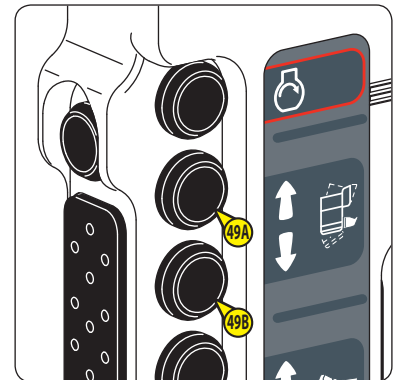
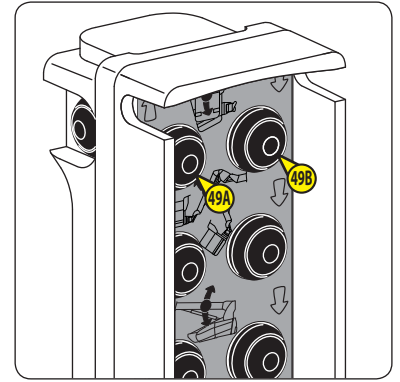

SCREEN DISPLAY - DESCRIPTION OF PAGES

START-UP PAGE

Once the platform is powered up, the start-up page is displayed briefly, then the PREHEAT PAGE is displayed.

NOTE: The current time is displayed at the top of each page. The platform serial number is displayed at the bottom of each page.

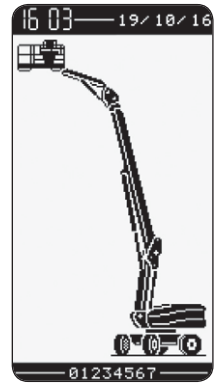

PREHEAT PAGE

The preheat page is displayed during the engine preheat cycle. The bar graph increases in proportion to the preheat cycle time that has elapsed.

The preheat cycle is completed when the bar graph is full.

A search for faults/alarms is carried out automatically:

- If no fault is detected and no alarm is triggered:
 - The ENGINE STARTING PAGE is displayed.
 - The audible alarm sounds once.
- If a fault is detected: A FAULT PAGE is displayed.
- If an alarm is triggered: An ALARM PAGE is displayed.

NOTE: The battery voltage ① and the fuel level ② are displayed on the PREHEAT PAGE, the ENGINE STARTING PAGE, the WORK PAGE and the FAULT PAGE.

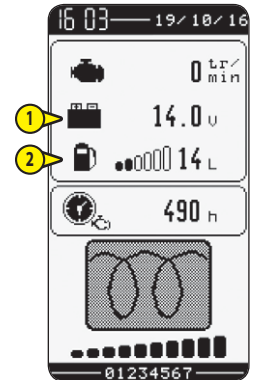

ENGINE START PAGE







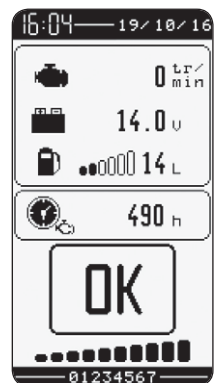

The engine can be started when OK is displayed.

To access the menu page, refer to MENU PAGE.

The WORK PAGE is displayed when the engine is started.



MENU PAGE

- Press the MENU key  to display the MENU PAGE.
- Select a menu by pressing the ARROW keys   and confirm by pressing the key OK .
- Select a sub-menu (if necessary) by pressing the MINUS/PLUS keys   and confirm by pressing the key OK .
- Return to the WORK PAGE by pressing the MENU key .

NOTE:  DEFINITION OF SUB-MENUS.

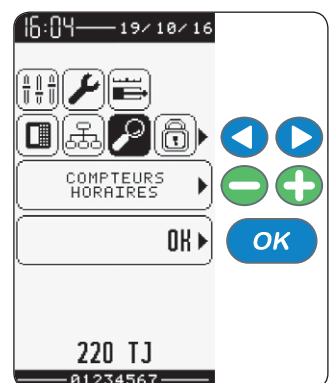

EDITING A SUB-MENU

- After selecting a menu, select the required sub-menu (if necessary) using the ARROW keys .
- Press the MINUS/PLUS keys to change the settings.
- Confirm by pressing the key OK . A confirmation message is displayed.
- Press the key OK again to confirm.
- Return to previous page by pressing the key EXIT .
- Return to the MENU PAGE by pressing the MENU key .

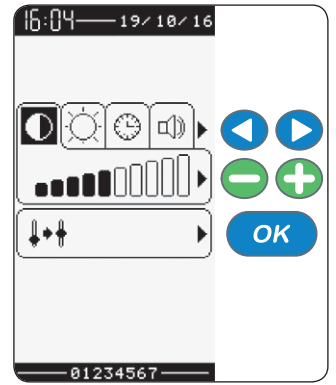

NOTE: DEFINITION OF SUB-MENUS.

WORKING PAGE

The WORK PAGE is displayed by default, and the basket controls are activated.

The WORK PAGE is displayed when the ground controls are activated.

NOTE: CONTROL PANEL AND SAFETY DEVICES ON THE GROUND.

The WORK PAGE is displayed when the remote controls are activated.

NOTE: REMOTE CONTROL UNIT.

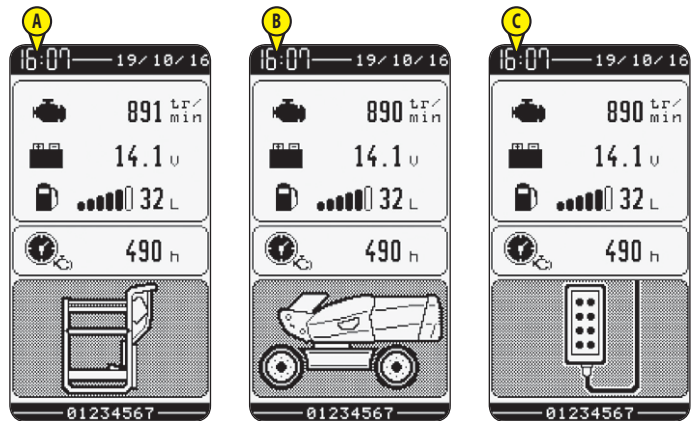

! IMPORTANT !

A maintenance operation could be necessary when the maintenance alert (spanner) is displayed. Refer to the maintenance personnel.

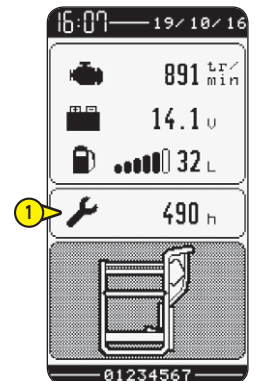

FAULT PAGE

! IMPORTANT !

Certain controls may be locked depending on the fault. Refer to the maintenance personnel if there is a fault.

A FAULT PAGE is displayed when a fault is detected.

- Press the FAULT key to display the FAULT CODE/ALARM PAGE.



ALARM PAGE

An ALARM PAGE is displayed intermittently with the FAULT PAGE or the WORK PAGE when an alarm is triggered.

- Resolve the problem to return to the WORK PAGE.

NOTE: Depending on the type of alarm press the FAULT key  to display the FAULT CODE/ALARM PAGE.

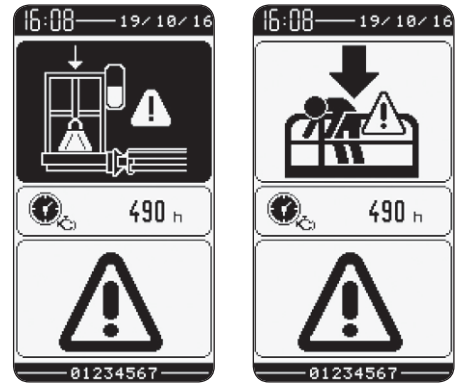

NOTE: The illustrations show 2 examples of alarms.



Depending on version:

This ALARM PAGE is displayed when the platform is powered up without starting the engine in the next 10 seconds.

To cancel this alarm page:

- Turn the ignition switch to position .
- Turn the ignition switch to position .
- Wait for the preheat cycle to finish and start up the engine.

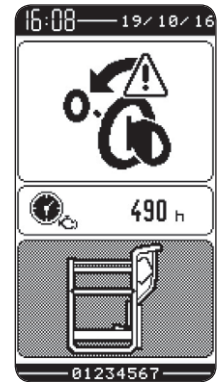

FAULT/ALARM CODE PAGE



The fault/alarm code and its description are displayed on this page.

- Press the key OK  so that the fault or alarm is no longer displayed. This action is recorded in the faults/alarm history.

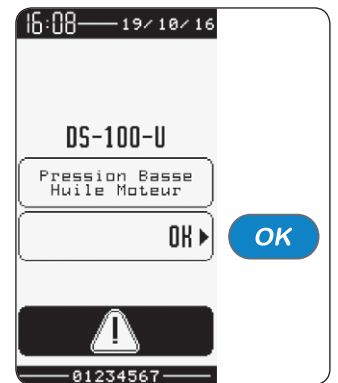
NOTE: The illustration shows an example of a fault code.



DEFINITION OF SUB-MENUS



	Menus/sub-menus	User		Dealers/Rental companies	
		Access code not required		Access code required	
		Display	Adjustment of parameters	Display	Adjustment of parameters
	"Code" Code		<input type="radio"/>		<input type="radio"/>
	"Options" Options	"Klaxon mode" Horn mode (1)		<input type="radio"/>	<input type="radio"/>
		"Always flash. light" Permanent rotating beacon light (2)		<input type="radio"/>	<input type="radio"/>
		"Generator options" Generator options			<input type="radio"/>
		"Drive in working mode" Travel when working			<input type="radio"/>
		"Tilt in working mode" Tilting when working			<input type="radio"/>
		"Auto straight wheel" Wheel realignment			<input type="radio"/>
		"Safe Man System"			<input type="radio"/>
		"Auto retract tel. (SMS)" Automatic telescope boom retraction (SMS) (3)			<input type="radio"/>
		"Reduce speed fast + bkwd" Reversing speed + hare reduction			<input type="radio"/>
		"Easy manager"			<input type="radio"/>
		"Box config Easy manager" Box configuration Easy manager			<input type="radio"/>
	"Language" Language	English			<input type="radio"/>
		Deustch			<input type="radio"/>
		Nederlands			<input type="radio"/>
		Français			<input type="radio"/>
	"System parameters" System parameters	"Engine management" Engine management			<input type="radio"/>
		"Arm management" Jib management			<input type="radio"/>
		"Arm bumper" Jib stop			<input type="radio"/>
		"Telescop management" Telescope management			<input type="radio"/>
		"Telescop bumper" Telescope stop			<input type="radio"/>
		"Jib management" Jib management			<input type="radio"/>
		"Turret management" Turntable management			<input type="radio"/>
		"Bskt levell mgmt" Basket tilting management			<input type="radio"/>
		"Bskt rotation mgmt" Basket rotation management			<input type="radio"/>
		"Jib trim" Jib attitude			<input type="radio"/>
		"X-Y Control" X-Y Control			<input type="radio"/>
		"Jib tilting mgmt" Jib tilt management			<input type="radio"/>
		"Jib tel mgmt" Jib telescope management			<input type="radio"/>
		"Jib tel bumper" Jib telescope stop			<input type="radio"/>
		"Steering management" Steering management			<input type="radio"/>
		"Generator" Generator			<input type="radio"/>
		"Maint periods" Maintenance periods			<input type="radio"/>
		"USB download" Transfer USB			<input type="radio"/>

(1): "NONE" = NONE, "AVCT" = DRIVING/STEERING ALARM, "MVT" = ALL MOVEMENTS ALARM.

(2): PERMANENT ORANGE ROTATING BEACON LIGHT: "OFF" = deactivated, "ON" = activated.

(3): AUTOMATIC TELESCOPE RETRACTION: "OFF" = deactivated, "ON" = activated.

NOTE: The texts in inverted commas are displayed when the language "English" (English) is selected.



	Menus/sub-menus		User		Dealers/Rental companies	
			Access code not required		Access code required	
			Display	Adjustment of parameters	Display	Adjustment of parameters
	"Maintenance" Maintenance	"Oil change" Oil change (4)	⊙			⊙
		"Oil filter" Oil filter (4)	⊙			⊙
		"Air filter" Air filter (4)	⊙			⊙
		"Fuel filter" Diesel filter (4)	⊙			⊙
		"Hydraulic filter" Hydraulic filter (4)	⊙			⊙
		"Hydrostat filter" Hydrostatic filter (4)	⊙			⊙
		"Lubrication" Lubrication (4)	⊙			⊙
		"Mechanical check" Mechanics inspection (4)	⊙			⊙
"Maintenance History" Maintenance history				⊙		
	"Speed calibration" Speed calibration	"Arm lifting up" Jib raising				⊙
		"Arm lifting down" Jib lowering				⊙
		"Extend telescop" Telescope extension				⊙
		"Retract telescop" Telescope retraction				⊙
		"Jib lifting up" Raising jib				⊙
		"Jib lifting down" Lowering jib				⊙
		"Right rotating turret" Right turntable rotation				⊙
		"Left rotating turret" Left turntable rotation				⊙
		"Basket right rotation" Right basket rotation				⊙
		"Basket left rotation" Left basket rotation				⊙
		"Forward drive working mode" Work forward travel			⊙	
		"Backward drive working mode" Working reverse travel			⊙	
	"Telescope calibration" Telescope calibration	"Extend setting measurement" Extension measurement adjustment				⊙
		"Retract setting measurement" Retraction measurement adjustment				⊙
	"400 kg Overload calibration" 400 kg overload calibration (5)					⊙
	"240 kg Overload calibration" 240 kg overload calibration (6)					⊙
	"350 kg Overload calibration" 350 kg overload calibration (6)					⊙
	"Arm angle calibration" Jib angle calibration					⊙
	"Jib tilting calibration" Jib tilting calibration					⊙
	"Jib compens calibration" Jib compensation calibration					⊙
	"Generator calibration" Generator calibration					⊙
	"Pressure setting" Pressure adjustments					⊙
	"Cycle running in" Running-in cycle	"Arm" Arm				⊙
		"Telescope" Telescope				⊙
"Parameters setting" Parameter management	"Mach parameters restoration" Restore machine parameters				⊙	
	"Mach parameters saving" Save machine parameters				⊙	
	"Raw factory prm restoration" Restore basic factory values				⊙	
"Engine accel calibration" Engine acceleration calibration					⊙	
"Joysticks calibration" Joystick calibration					⊙	

(4): "at / to do in / urgent" = in / to do / urgent.

(5): Only for 260 TJ.

(6): Only for 280 TJ.

NOTE: The texts in inverted commas are displayed when the language "English" (English) is selected.

	Menus/sub-menus		User		Dealers/Rental companies		
			Access code not required		Access code required		
			Display	Adjustment of parameters	Display	Adjustment of parameters	
	"Screen settings" Screen adjustments	"Contrast" Contrast		<input type="radio"/>		<input type="radio"/>	
		"Brightness" Light level		<input type="radio"/>		<input type="radio"/>	
		"Date and time" Date and time		<input type="radio"/>		<input type="radio"/>	
		"Button tones" Key beeps		<input type="radio"/>		<input type="radio"/>	
	"Codification" Codification		<input type="radio"/>		<input type="radio"/>		
	"Machine selection" Machine selection					<input type="radio"/>	
	"Hour counters" Hour counter	"Rental" Rental	<input type="radio"/>			<input type="radio"/>	
		"Engine" Engine	<input type="radio"/>		<input type="radio"/>		
	"Day hours" Daily hours		<input type="radio"/>		<input type="radio"/>		
	"Input/output visualisation" Input/output display	"General" General		<input type="radio"/>		<input type="radio"/>	
		"Power supply" Power supplies		<input type="radio"/>		<input type="radio"/>	
		INTOR UPC30		<input type="radio"/>		<input type="radio"/>	
		INANA UPC30		<input type="radio"/>		<input type="radio"/>	
		HSCE UPC30		<input type="radio"/>		<input type="radio"/>	
		OUTTOR UPC30		<input type="radio"/>		<input type="radio"/>	
		OUTLED UPC110		<input type="radio"/>		<input type="radio"/>	
		OUTANA UPC30		<input type="radio"/>		<input type="radio"/>	
	OUTPWM UPC30		<input type="radio"/>		<input type="radio"/>		
	"Diagnostic" Diagnostics	"Lifting arm" Jib raising		<input type="radio"/>		<input type="radio"/>	
		"Lowering arm" Jib lowering		<input type="radio"/>		<input type="radio"/>	
		"Telescope extend" Telescope extension		<input type="radio"/>		<input type="radio"/>	
		"Telescope retract" Telescope retraction		<input type="radio"/>		<input type="radio"/>	
		"Lifting jib" Raising jib		<input type="radio"/>		<input type="radio"/>	
		"Lowering jib" Lowering jib		<input type="radio"/>		<input type="radio"/>	
		"Turret rotation" Turntable rotation		<input type="radio"/>		<input type="radio"/>	
		"Lifting basket tilt" Basket tilting up		<input type="radio"/>		<input type="radio"/>	
		"Lowering basket tilt" Basket tilting down		<input type="radio"/>		<input type="radio"/>	
		"Lifting jib tilt" Jib tilt raising		<input type="radio"/>		<input type="radio"/>	
		"Lowering jib tilt" Jib tilt lowering		<input type="radio"/>		<input type="radio"/>	
		"Basket rotation" Basket rotation		<input type="radio"/>		<input type="radio"/>	
		"Extend jib telescope" Jib telescope extension		<input type="radio"/>		<input type="radio"/>	
		"Retract jib telescope" Jib telescope retraction		<input type="radio"/>		<input type="radio"/>	
		"Leveling" Attitude levelling		<input type="radio"/>		<input type="radio"/>	
		"Auto leveling jib tilt" Automatic correction of jib tilt		<input type="radio"/>		<input type="radio"/>	
		"Lifting Y control" Y control raising		<input type="radio"/>		<input type="radio"/>	
		"Lowering Y control" Y control lowering		<input type="radio"/>		<input type="radio"/>	
		"Extend X control" X control extension		<input type="radio"/>		<input type="radio"/>	
		"Retract X control" X control retraction		<input type="radio"/>		<input type="radio"/>	
"Driving" Platform travel		<input type="radio"/>		<input type="radio"/>			
"Steering" Platform steering		<input type="radio"/>		<input type="radio"/>			
"Generator activation" Generator activation		<input type="radio"/>		<input type="radio"/>			
"Engine starter" Engine starting		<input type="radio"/>		<input type="radio"/>			
"Defaults history" Fault history		<input type="radio"/>		<input type="radio"/>			

NOTE: The texts in inverted commas are displayed when the language "English" (English) is selected.

USING THE PLATFORM

⚠ IMPORTANT ⚠

Part 1 - INSTRUCTIONS AND SAFETY INSTRUCTIONS must be read and understood before operating the platform.

TRANSPORT/WORKING POSITION

TRANSPORT POSITION

The platform in the transport position when:

- The main jib is completely lowered.
- The telescope is completely retracted.
- The jib telescope is completely retracted (only for 280 TJ).

NOTE: The jib may or may not be raised. The turntable and basket may or may not be turned.

The turntable and the basket are in the neutral position when the main jib and the basket are parallel to the platform chassis, with the basket between the 2 rear wheels.

Front, rear, left and right are defined as follows:

- The platform is in transport position.
- The turntable and basket are in the neutral position.
- The operator is in the basket facing the direction of the front wheels.

The driving speeds, TORTOISE, RAMP and HARE, can only be selected in the transport position.

Use RAMP speed (slow speed with full power) to travel on steep slopes, move over very rough terrain or go up/down transport truck loading ramps.

NOTE: Depending on conditions, restrictions may apply to the speed activated, refer to the following page.

WORKING POSITION

⚠ IMPORTANT ⚠

Travelling over rough terrain, on unstable ground, on slopes that are steeper than those authorised, (< CHARACTERISTICS) or in any other conditions likely to cause the platform to tip up or become destabilised, is PROHIBITED.

The platform is in the transport position when:







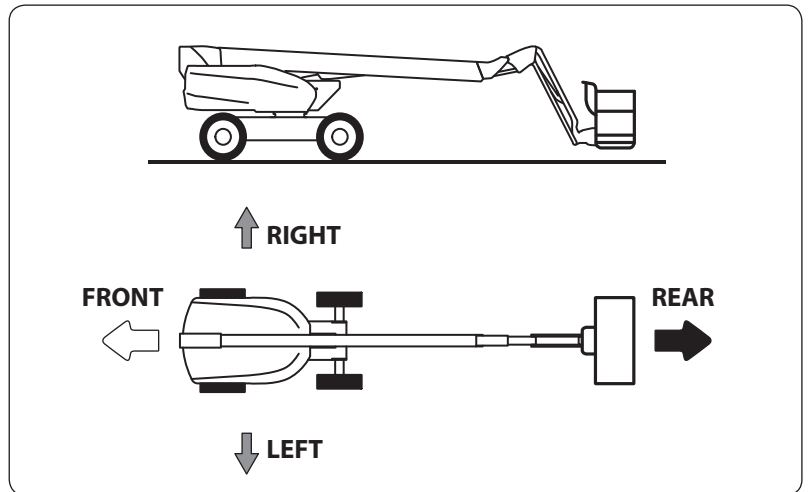





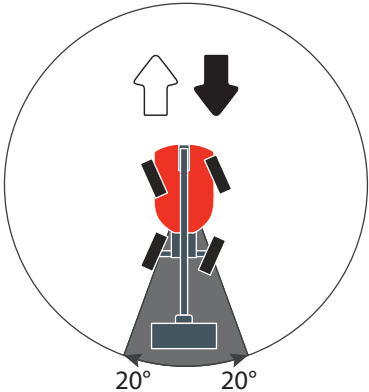



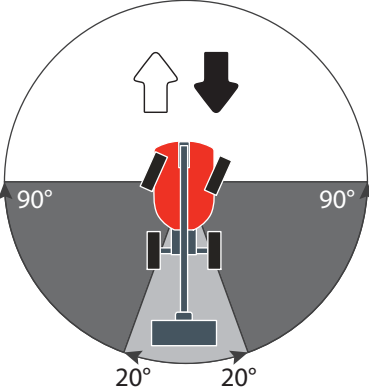



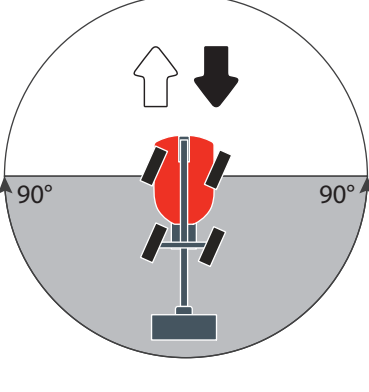

- The main jib is not completely lowered.
- The telescope is not completely retracted.
- The jib telescope is not completely retracted (only for 280 TJ).

NOTE: The jib may or may not be raised. The turntable and basket may or may not be turned.

WORKING POSITION driving speed is automatically activated when the platform is in working position.



DRIVING SPEED ACTIVATED DEPENDING ON THE STEERING MODE SELECTED, THE POSITION OF THE TURNABLE AND THE DRIVING SPEED SELECTED (TRANSPORT POSITION ONLY)

		DRIVING SPEED SELECTED		
		TORTOISE 	RAMP 	HARE 
STEERING MODE SELECTED	POSITION OF THE TURNABLE	DRIVING SPEED ACTIVATED		
4 STEERING WHEELS 	< 20°	TORTOISE 	RAMP 	RAMP (1) 
	> 20° < 90°	SLOW	SLOW	SLOW (1)
	> 90°	SLOW (1)	SLOW (1)	SLOW (1)
2 STEERING WHEELS 	< 20°	TORTOISE 	RAMP 	HARE (1)  RAMP (1) 
	> 20° < 90°	TORTOISE 	RAMP (1) 	RAMP (1) 
	> 90°	SLOW (1)	SLOW (1)	SLOW (1)
CRAB 	< 20°	TORTOISE 	RAMP 	HARE (1)  RAMP (1) 
	> 20° < 90°	TORTOISE 	RAMP 	HARE (1)  RAMP (1) 
	> 90°	SLOW (1)	SLOW (1)	SLOW (1)

(1): Driving and turntable rotation cannot be actioned simultaneously.

NOTE: SLOW speed is activated automatically and cannot be selected manually.

OPERATION FROM THE GROUND LEVEL CONTROL PANEL

⚠ IMPORTANT ⚠

☞ **CONTROL PANEL AND SAFETY DEVICES ON THE GROUND** for detailed information about the ground controls.

SWITCH THE PLATFORM ON

- Ensure that the emergency stop buttons on the ground and basket control panels and the remote control unit are in the ON position.
- BATTERY CUT-OFF option: Turn the battery cut-off to the ON position.
- Turn the ignition switch to position .

Result:

- The interface screen lights up, ☞ **SCREEN DISPLAY: DESCRIPTION OF PAGES**.



NOTE: SECONDARY PROTECTION SYSTEM option "SAFEMANSYSTEM", ☞ **OPTIONS**.

NOTE: The horn sounds twice and one specific alarm page is displayed when the platform is turned on without starting the engine in the next 10 seconds, ☞ **SCREEN DISPLAY - DESCRIPTION OF PAGES: ALARM PAGES**.

TURN THE PLATFORM OFF

- Turn the ignition switch to position .
- BATTERY CUT-OFF option: Turn the battery cut-off to the OFF position.

START THE ENGINE

- Switch on the access platform.
- Wait for the preheat cycle to finish, ☞ **SCREEN DISPLAY - DESCRIPTION OF PAGES**.
- Start the engine, ☞ **ENGINE STARTER BUTTON** and ☞ **ENGINE STARTING MODE BUTTON** if the outside temperature is lower than -10 °C.
- If the engine does not start:
 - Turn the ignition switch to position , turn it to position .
 - Wait for the preheat cycle to finish and try to start the engine again.

NOTE: Consult the maintenance staff if the engine fails to start after several attempts.

SWITCH OFF THE ENGINE

⚠ IMPORTANT ⚠

Wait several minutes for the engine to cool down before stopping it after intensive use.

- Turn ignition key to position  or press the emergency stop button (OFF position).

POSITION THE BASKET

- Ensure that the turntable is unlocked, ☞ **SAFETY COMPONENTS: TURNTABLE LOCKING PIN**.
- Push and hold the ground level/basket control selection switch to the right .
- Press the appropriate control keys to activate the platform controls.
- Release the keys or the switch to stop activated controls.

NOTE: Use key combinations to operate the simultaneous controls, ☞ **SIMULTANEOUS CONTROLS**.

EMERGENCY STOP

- Press the emergency stop button (OFF position).

OPERATION FROM THE BASKET CONTROL PANEL

⚠ IMPORTANT ⚠

⚠ **CONTROL PANEL AND SAFETY DEVICES IN THE BASKET** for detailed information about the controls in the basket.

TURN THE PLATFORM ON/OFF

⚠ OPERATION FROM THE GROUND LEVEL CONTROL PANEL.

START THE ENGINE

- Switch on the access platform.
- Wait for the preheat cycle to finish, ⚠ PREHEAT INDICATOR LIGHT.
- Start the engine, ⚠ ENGINE STARTER BUTTON.

NOTE: ⚠ OPERATING FROM THE GROUND CONTROL PANEL if the outside temperature is lower than -10 °C.

- If the engine does not start:
 - Press the emergency stop button (OFF position), turn it a quarter turn to the right and release it (ON position).
 - Wait for the preheat cycle to finish and try to start the engine again.

NOTE: Consult the maintenance staff if the engine fails to start after several attempts.

SWITCH OFF THE ENGINE

⚠ IMPORTANT ⚠

Wait several minutes for the engine to cool down before stopping it after intensive use.

- Press the emergency stop button (OFF position).

DRIVE AND STEER

⚠ IMPORTANT ⚠

Always refer to the arrow colours on the chassis and on the control panel in the basket before driving/steering the platform.

- Ensure that the turntable is unlocked, ⚠ SAFETY COMPONENTS: TURNTABLE LOCKING PIN.
- Put the driving speed selection switch into the desired speed position.
- Put the driving speed selection switch into the desired steering position.
- Press and hold down the foot switch.
- Use the appropriate control handle to drive, steer and brake.

POSITION THE BASKET

- Ensure that the turntable is unlocked, ⚠ SAFETY COMPONENTS: TURNTABLE LOCKING PIN.
- Press and hold down the foot switch.
- Use the appropriate buttons, switches and/or control handles to operate the platform controls.
- Release the buttons, switches and/or control handles or the foot switch to stop controls that have been activated.

NOTE: Use key combinations to operate the simultaneous controls, ⚠ SIMULTANEOUS CONTROLS.

EMERGENCY STOP

- Press the emergency stop button (OFF position).

OPERATION FROM THE REMOTE CONTROL UNIT

⚠ IMPORTANT ⚠

◀ **REMOTE CONTROL UNIT** for detailed information about the remote controls.

The remote control unit is only activated when:

- The turntable angle is less than 90° (to left or right) in relation to the neutral position.
- The angle of the main jib is 15° maximum in relation to the completely lowered position.
- The telescope is completely retracted.

TURN THE PLATFORM ON/OFF

◀ OPERATION FROM THE GROUND LEVEL CONTROL PANEL.

START THE ENGINE

- Switch on the access platform.
- Wait for the preheat cycle to finish, ▶ SCREEN DISPLAY - DESCRIPTION OF PAGES.
- Start the engine, ▶ ENGINE STARTER BUTTON.

NOTE: ▶ OPERATING FROM THE GROUND CONTROL PANEL if the outside temperature is lower than -10 °C.

- If the engine does not start:
 - Press the emergency stop button (OFF position).
 - First and second version: Turn the button a quarter turn to the right and release it (ON position).
 - Third version: Pull the button or turn it a quarter turn to the right and release it (ON position).
 - Wait for the preheat cycle to finish and try to start the engine again.

NOTE: Consult the maintenance staff if the engine fails to start after several attempts.

SWITCH OFF THE ENGINE

- Press the emergency stop button (OFF position).

POSITION THE BASKET

- Press and hold down the activation button.
- Press the appropriate control buttons to activate platform controls.
- Release the control buttons or the activation button to stop controls that have been activated.

NOTE: Use key combinations to operate the simultaneous controls, ▶ SIMULTANEOUS CONTROLS.

EMERGENCY STOP

- Press the emergency stop button (OFF position).

SIMULTANEOUS CONTROLS

NOTE: The audible warning sounds twice when the controls cannot be operated simultaneously.

GROUND CONTROL PANEL

In the transport/working position: a maximum of 2 controls can be operated simultaneously.

CONTROL PANEL IN THE BASKET

In the transport/working position: a maximum of 4 controls can be operated simultaneously.

REMOTE CONTROL UNIT

In the transport/working position: a maximum of 2 controls can be operated simultaneously.

CONTROLS LOCKED

Some controls are locked (refer to the tables below):

- When the basket load has reached maximum capacity (OVERLOAD ALARM).
- When the platform is on a steep slope (LEVELLING/OSCILLATION ALARM).
- When a locking fault in the oscillating axle is detected*, (LEVELLING/OSCILLATION ALARM).

*: For 260 TJ and from machine no. 950124 for 280 TJ.

- When a telescope cable slack or cut (CABLE BREAKAGE ALARM).

TRANSPORT POSITION

CONTROLS COMMON TO GROUND LEVEL AND BASKET	OVERLOAD ALARM	TILT/OSCILLATION ALARM	CABLE BREAKAGE ALARM
RAISE THE MAIN JIB	LOCKED	LOCKED	
EXTEND THE TELESCOPE	LOCKED	LOCKED	LOCKED
TURN THE TURNTABLE (LEFT/RIGHT)	LOCKED		
RAISE/LOWER THE JIB	LOCKED		
EXTEND THE JIB TELESCOPE - ONLY FOR 280 TJ	LOCKED	LOCKED	LOCKED
TILT BASKET/JIB UP	LOCKED	LOCKED	
TILT BASKET/JIB DOWN	LOCKED	LOCKED	

SPECIFIC CONTROLS IN THE BASKET	OVERLOAD ALARM	TILT/OSCILLATION ALARM	CABLE BREAKAGE ALARM
TILT THE BASKET UPWARDS/DOWNWARDS - ONLY FOR 280 TJ	LOCKED	LOCKED	
TURN THE BASKET (LEFT/RIGHT)	LOCKED		
DRIVE (FORWARD/BACKWARD)	LOCKED		
STEER (LEFT/RIGHT)	LOCKED		

WORKING POSITION

CONTROLS COMMON TO GROUND LEVEL AND BASKET	OVERLOAD ALARM	TILT/OSCILLATION ALARM	CABLE BREAKAGE ALARM
RAISE THE MAIN JIB	TELESCOPE RETRACTED	LOCKED	LOCKED
	TELESCOPE EXTENDED	LOCKED	LOCKED
LOWER THE MAIN JIB	TELESCOPE RETRACTED	LOCKED	
	TELESCOPE EXTENDED	LOCKED	LOCKED
EXTEND THE TELESCOPE	LOCKED	LOCKED	LOCKED
RETRACT THE TELESCOPE	LOCKED		
TURN THE TURNTABLE (LEFT/RIGHT)	TELESCOPE RETRACTED	LOCKED	
	TELESCOPE EXTENDED	LOCKED	LOCKED
RAISE/LOWER THE JIB - ONLY FOR 260 TJ	LOCKED		
RAISE/LOWER THE JIB - ONLY FOR 280 TJ	JIB TELESCOPE RETRACTED	LOCKED	
	JIB TELESCOPE EXTENDED	LOCKED	LOCKED
EXTEND THE JIB TELESCOPE - ONLY FOR 280 TJ	LOCKED	LOCKED	
RETRACT THE JIB TELESCOPE - ONLY FOR 280 TJ	LOCKED		
TILT BASKET/JIB UP	LOCKED	LOCKED	
TILT BASKET/JIB DOWN	LOCKED	LOCKED	

SPECIFIC CONTROLS IN THE BASKET	OVERLOAD ALARM	TILT/OSCILLATION ALARM	CABLE BREAKAGE ALARM
TILT THE BASKET UPWARDS/DOWNWARDS - ONLY FOR 280 TJ	LOCKED	LOCKED	
TURN THE BASKET (LEFT/RIGHT)	LOCKED		
DRIVE (FORWARD/BACKWARD)	LOCKED	LOCKED	
STEER (LEFT/RIGHT)	LOCKED	LOCKED	

TRANSPORTING THE PLATFORM

⚠ IMPORTANT ⚠

Check that the safety instructions associated with the flatbed have been correctly applied before loading the platform and ensure that the driver of the vehicle has been informed of the dimensional characteristics and total weight of the platform.

Ensure that the flatbed has adequate dimensions and load capacity for transporting the platform, (⚠ CHARACTERISTICS and STICKERS.

There is a risk of the platform losing grip (sliding or skidding) when going up and down the loading ramps if they are wet, muddy or show any signs of dampness. In this case it is necessary to winch the platform, (⚠ 3 - MAINTENANCE: OCCASIONAL OPERATION: WINCHING.

Adapt the driving speed of the platform by slowly actioning the proportional control lever.

It is essential that the turntable is locked when the platform is being transported (⚠ SAFETY COMPONENTS: TURNTABLE LOCKING PIN).

It is essential that the covers are closed and locked (if applicable) when the platform is being transported.

LOADING/UNLOADING THE PLATFORM

⚠ IMPORTANT ⚠

The turntable must be locked before loading the platform onto a transport flatbed or before unloading it (⚠ SAFETY COMPONENTS: TURNTABLE LOCKING PIN).

The platform must be driven forward with the counterweight at the top of the ramp when it is loaded onto a flatbed truck. See the illustration below.

The platform must be driven in reverse with the counterweight at the top of the ramp when it is unloaded, see the illustration below.

- Block the wheels of the flatbed truck with chocks (1).
- Attach the loading ramps to the flatbed truck so as to achieve the lowest possible (2) angle.
- Put the platform should be in the transport position; put the turntable and the basket in the neutral position (⚠ OPERATING THE PLATFORM: TRANSPORT/WORKING POSITION).

NOTE: The jib may be slightly raised so that the basket does not touch the ground, hold it in the lowest possible position during manoeuvres.

- Select RAMP speed.
- Drive the platform to load it onto or unload it from the flatbed truck.

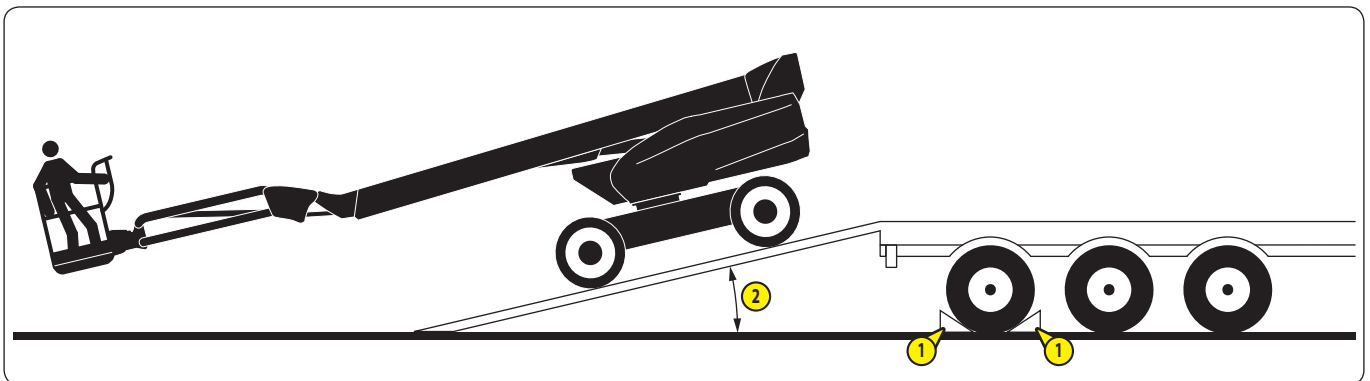

CONFIGURE THE PLATFORM FOR TRANSPORT 260 TJ

FOLDED POSITION:

- OPERATING THE PLATFORM: TRANSPORT/WORKING POSITION:
 - Place the platform in the transport position.
 - Place the turntable and basket in the neutral position.
- Lower the jib
- Raise the main jib (15° maximum).
- Tilt the basket/jib downwards to fold the basket under the main jib. Ensure that the basket cannot hit the flatbed.
- Lower the main jib so that the basket is a distance of about 10 cm from the flatbed.

NOTE: STICKERS: FOLDING/UNFOLDING THE PLATFORM

NOTE: A remote control unit is available, REMOTE CONTROL UNIT for instructions for use.

MOVE FROM THE FOLDED POSITION TO THE TRANSPORT POSITION:

- Raise the main jib (15° maximum).
- Tilt the basket/jib upwards until the basket floor is horizontal. Ensure that the basket cannot hit the flatbed.
- Fully lower the main jib.

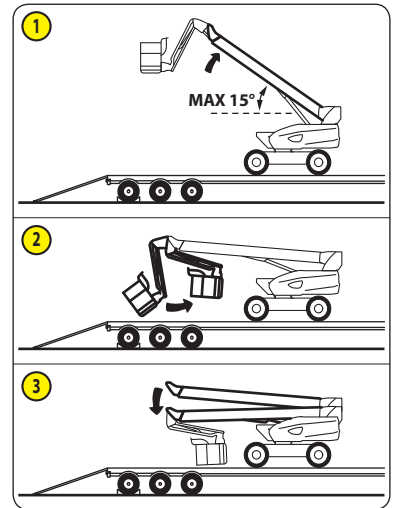

CONFIGURE THE PLATFORM FOR TRANSPORT 280 TJ

FOLDED POSITION:

- OPERATING THE PLATFORM: TRANSPORT/WORKING POSITION:
 - Place the platform in the transport position.
 - Place the turntable and basket in the neutral position.
- Lower the jib
- Raise the main jib (15° maximum).
- Tilt the basket fully downwards. Ensure that the basket cannot hit the flatbed.
- Tilt the basket/jib downwards to fold the basket under the main jib. Ensure that the basket cannot hit the flatbed.
- Lower the main jib so that the basket is a distance of about 10 cm from the flatbed.

NOTE: STICKERS: FOLDING/UNFOLDING THE PLATFORM

NOTE: A remote control unit is available, REMOTE CONTROL UNIT for instructions for use.

MOVE FROM THE FOLDED POSITION TO THE TRANSPORT POSITION:

- Raise the main jib (15° maximum).
- Tilt the basket/jib upwards until the gauge reaches the 0° mark on the sticker STICKER: JIB ANGLE. Ensure that the basket cannot hit the flatbed.
- Tilt the basket/jib upwards until the basket floor is horizontal. Ensure that the basket cannot hit the flatbed.
- Fully lower the main jib.

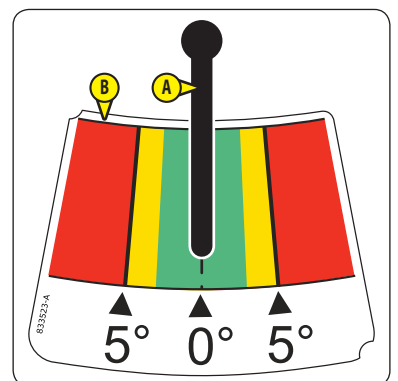
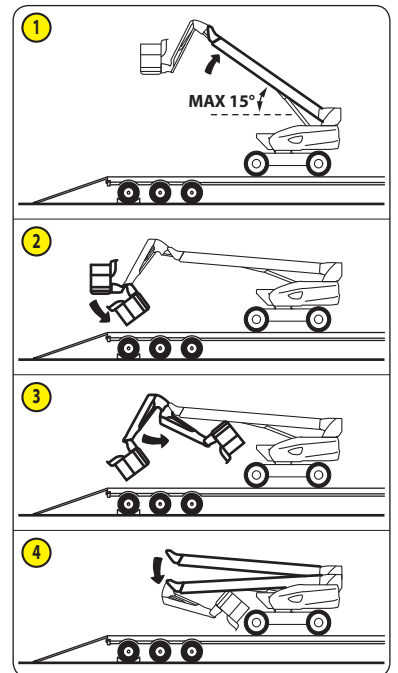

ANCHORING THE ACCESS PLATFORM

⚠ IMPORTANT ⚠

The platform is equipped with 8 lashing points (⚠ STICKERS: LASHING POINT); comply with the country's regulations concerning the minimum number of lashing points required when transporting a platform.

- Fix chocks ① to the flatbed truck at the front and rear of each of the platform's wheels.
- Fix chocks ② to the flatbed on the inner side of each of the platform's wheels.
- Lash the platform to the flatbed truck with sufficiently robust straps or chains ③ and/or ④ (according to country regulations) attached to the platform's lashing points (⚠ STICKERS: LASHING POINT).
- 260 TJ: Attach the basket with 2 straps ⑤ (supplied with the platform). Do not overtighten to avoid damage.
- 280 TJ: Attach the basket with 1 strap ⑤ (supplied with the platform). Do not overtighten to avoid damage.

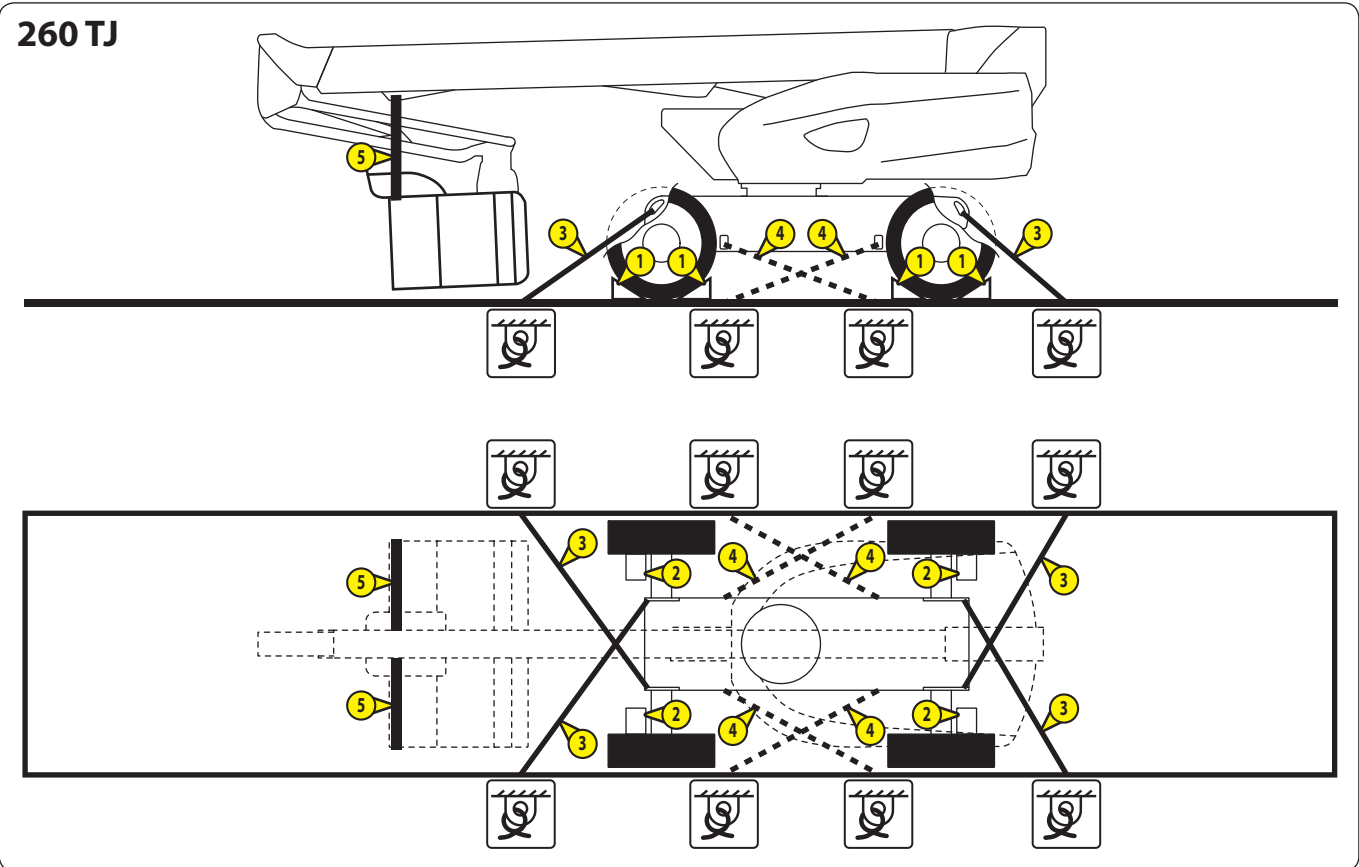

280 TJ

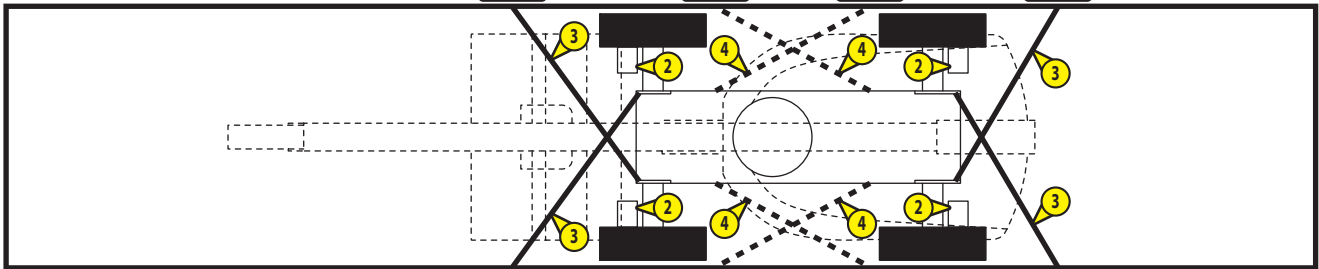
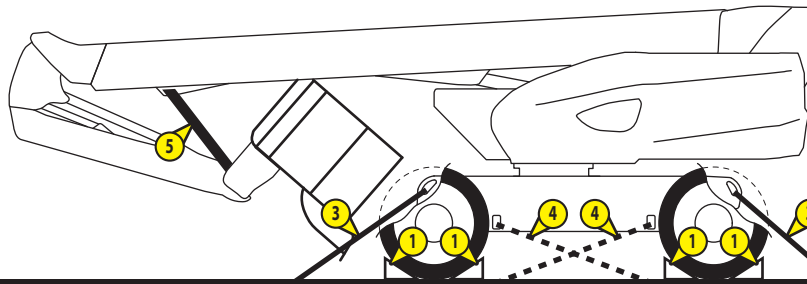

RESCUE PROCEDURE

⚠ IMPORTANT ⚠

This procedure should be read and fully understood by the operator and any other persons likely to be involved with working on the platform in the event of a breakdown or a person getting trapped in the basket.

SHOULD THE USER FEEL ILL - PRIORITY CONTROLS

If the operator in the basket should fall ill or find himself incapable of manoeuvring, the person present on the ground can take over the platform controls from the ground based control panel.

If the engine has been started:

- Push and hold the switch ① to the right .
- Lower the basket using the appropriate control keys.
- Release the keys or the switch to stop activated controls.

If the engine has not been started and the emergency stop button in the basket is in the ON position (interface is turned on):

- Switch on the engine.
- Push and hold the switch ① to the right .
- Lower the basket using the appropriate control keys.
- Release the keys or the switch to stop activated controls.

For 260 TJ and from machine no. 950124 for 280 TJ:

If the engine has not been started and the emergency stop button in the basket is in the OFF position (interface screen is off):

- Push and hold the switch ① to the right .
- Wait for the preheat cycle to finish and start up the engine.
- Lower the basket using the appropriate control keys.
- Release the keys or the switch to stop activated controls.

IF THERE IS A BREAKDOWN - EMERGENCY CONTROLS FROM THE BASKET

⚠ IMPORTANT ⚠

The backup pump should be activated for a maximum of 4 minutes, then wait 10 minutes before reactivating the pump for a new 4 minute cycle.

Do not try to use the controls simultaneously.

When a fault occurs in the engine, the platform has a backup pump, which can be activated from the basket control panel, allowing a return to the ground.

- Press and hold down the backup pump button ① to activate the backup pump.
- Use the controls on the control panel in the basket.
- Release the switches and/or control handles to stop the control that has been activated.
- Release backup pump button.

NOTE: It is not possible to drive/steer the platform.



IF THERE IS AN ACCIDENT OR BREAKDOWN - EMERGENCY CONTROLS

⚠ IMPORTANT ⚠

The tilt alarm and overload alarm may no longer be active while the emergency controls are in use.
 The backup pump should be activated for a maximum of 4 minutes, then wait 10 minutes before reactivating the pump for a new 4 minute cycle.

If an accident or breakdown occurs making the control panels at ground level and in the basket unusable, the platform is provided with emergency controls, which enable certain platform controls to be operated.

- - Open the right-hand turntable cover.
- Locate the various components of the emergency controls:
 - Backup pump button ①.
 - Proportional distributor ② and manual controls ②A to ②E.
 - Lever ③.
 - Secondary distributor ④ and manual control ④A.
- Use the controls described in the following pages.

NOTE: Refer to the stickers BACKUP PUMP ① and EMERGENCY CONTROL PROCEDURE ② and ③, ⚠ STICKERS.

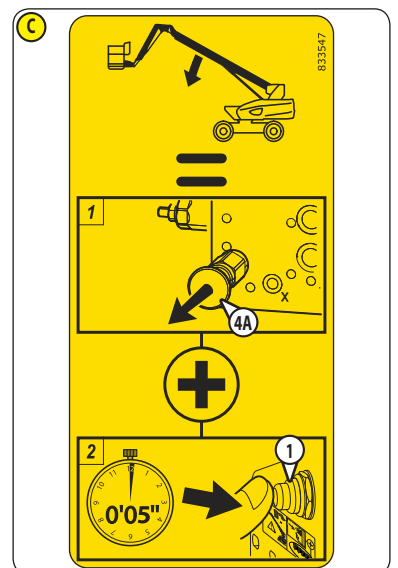
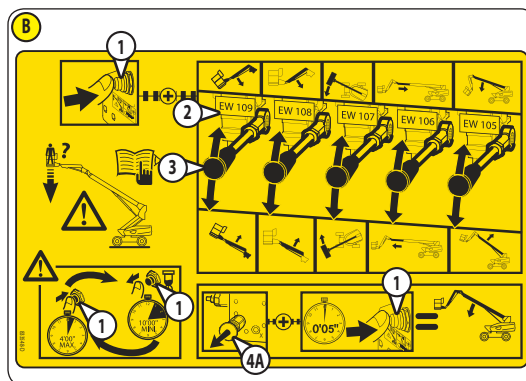
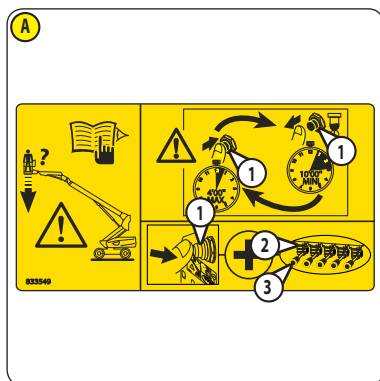
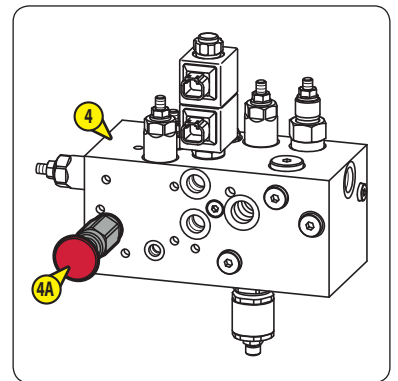
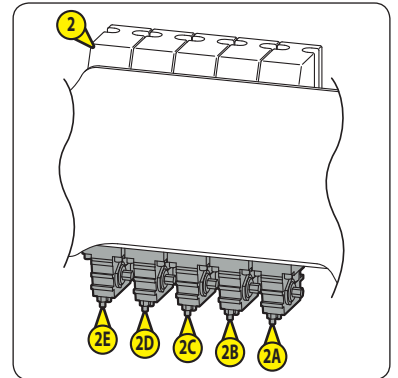
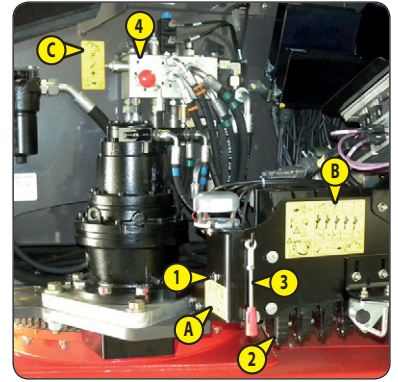

EMERGENCY CONTROLS FROM THE PROPORTIONAL DISTRIBUTOR ²

A- RAISE THE MAIN JIB

- 1 - Place the lever ³ on the manual control ^{2A}.
- 2 - Press the backup pump button ¹ and hold it down.
- 3 - Push the lever down to raise the main jib, stop when the desired position is reached. Release the backup pump button. Remove the lever.

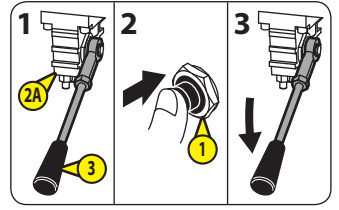

B- LOWER THE MAIN JIB

- 1 - Place the lever ³ on the manual control ^{2A}.
- 2 - Press the backup pump button ¹ and hold it down.
- 3 - Push the lever up to lower the main jib, stop when the desired position is reached. Release the backup pump button. Remove the lever.

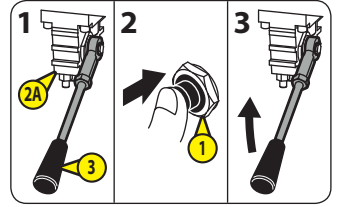

C - EXTEND THE TELESCOPE

- 1 - Place the lever ³ on the manual control ^{2B}.
- 2 - Press the backup pump button ¹ and hold it down.
- 3 - Push the lever down to extend the telescope, stop when the desired position is reached. Release the backup pump button. Remove the lever.

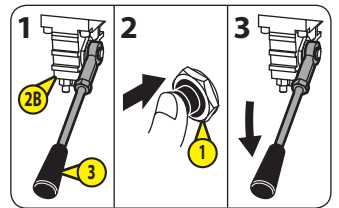

D - RETRACT THE TELESCOPE

- 1 - Place the lever ³ on the manual control ^{2B}.
- 2 - Press the backup pump button ¹ and hold it down.
- 3 - Push the lever up to retract the telescope, stop when the desired position is reached. Release the backup pump button. Remove the lever.

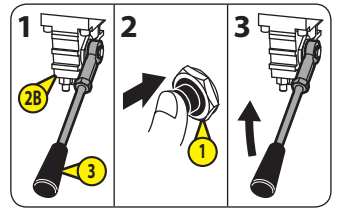

E- TURN THE TURNTABLE TO THE LEFT

- 1 - Place the lever ³ on the manual control ^{2C}.
- 2 - Press the backup pump button ¹ and hold it down.
- 3 - Push the lever down to turn the turntable to the left, stop when the desired position is reached. Release the backup pump button. Remove the lever.

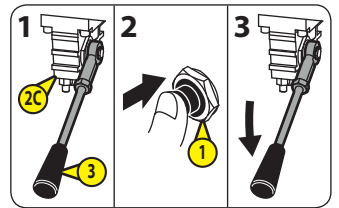

F- TURN THE TURNTABLE TO THE RIGHT

- 1 - Place the lever ³ on the manual control ^{2C}.
- 2 - Press the backup pump button ¹ and hold it down.
- 3 - Push the lever up to turn the turntable to the right, stop when the desired position is reached. Release the backup pump button. Remove the lever.

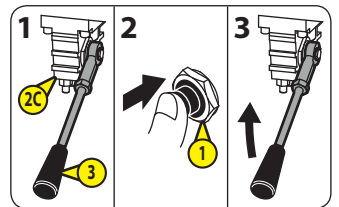

G- RAISE THE JIB

- 1 - Place the lever **3** on the manual control **2D**.
- 2 - Press the backup pump button **1** and hold it down.
- 3 - Push the lever down to raise the jib, stop when the desired position is reached. Release the backup pump button. Remove the lever.

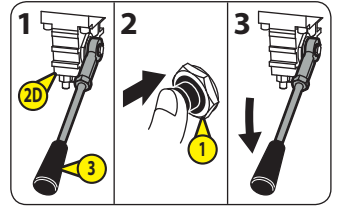

H- LOWER THE JIB

- 1 - Place the lever **3** on the manual control **2D**.
- 2 - Press the backup pump button **1** and hold it down.
- 3 - Push the lever up to lower the jib, stop when the desired position is reached. Release the backup pump button. Remove the lever.

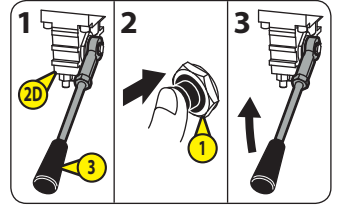

I- TILT BASKET/JIB UPWARDS

- 1 - Place the lever **3** on the manual control **2E**.
- 2 - Press the backup pump button **1** and hold it down.
- 3 - Push the lever down to tilt the basket/jib upwards, stop when the desired position is reached. Release the backup pump button. Remove the lever.

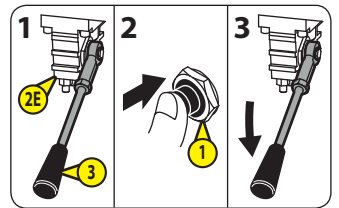

J- TILT BASKET/JIB DOWNWARDS

- 1 - Place the lever **3** on the manual control **2E**.
- 2 - Press the backup pump button **1** and hold it down.
- 3 - Push the lever up to tilt the basket/jib downwards, stop when the desired position is reached. Release the backup pump button. Remove the lever.

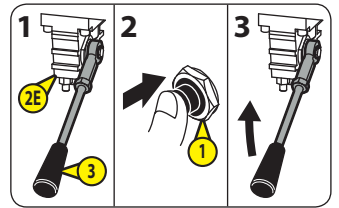

EMERGENCY CONTROLS FROM THE SECONDARY DISTRIBUTOR **4**

K- LOWER THE MAIN JIB

- 1 - Pull the manual control **4A** and hold it.
- 2 - Press and hold down the backup pump button **1** and hold it down for 5 seconds. Release the backup control once the main jib is lowered.

NOTE: If necessary, correct the tilt of the basket/jib,  EMERGENCY CONTROLS FROM THE PROPORTIONAL DISTRIBUTOR **2**.

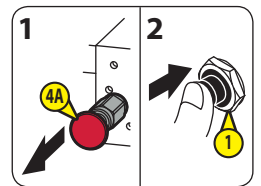

OPTIONS

1 - GENERATOR

⚠ IMPORTANT ⚠

Do not connect the cord extensions, power supply bars or plugs with multiple sockets to the electric power socket in the basket.

Overvoltages could occur when the generator is started.

The engine must be started to activate the generator.

- Press generator button **1** and release it to start the generator.
- Plug an electrical appliance into the electrical outlet in the basket.
- Press the generator button **1** and release it to stop the generator.

NOTE:

- Generator 110 V/3.5 kW: 1 electric power socket (UK) delivering 110 V/16 A maximum.
- Generator 220 V/3.5 kW: 1 electric power socket delivering 220 V/16 A maximum.
- Generator 220 V/5 kW: 2 electric power sockets delivering 220 V/16 A maximum.

The generator has a circuit breaker for resetting it:

- Press the generator button **1** and release it to stop the generator.
- Open the cover **A** at the rear of the turntable.
- Locate the switch **2** on the generator
- Push it to the ON position.

Result:

- The switch must remain in the ON position, the indicator **3** should be green.
- Press the generator button and release it to start the generator.
- Check that the switch remains in the ON position and that the indicator is green.
- Close the cover **A**.

NOTE: Refer to the maintenance personnel if the circuit breaker is not working correctly.

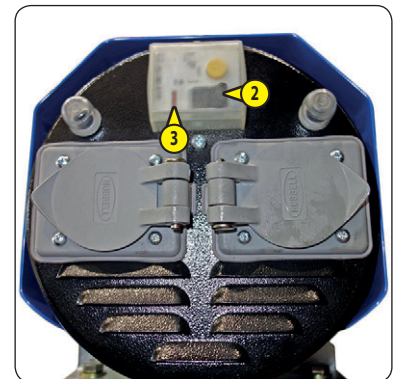
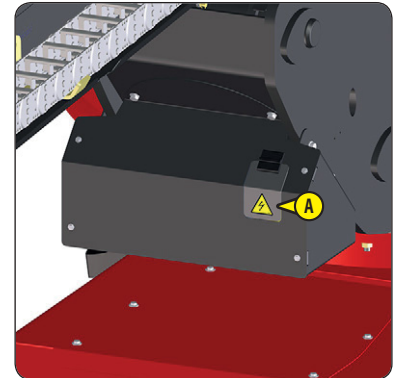

2 - SECONDARY PROTECTION SYSTEM "SAFEMANSYSTEM"

⚠ IMPORTANT ⚠

Operate the controls extremely carefully during attempts at clearance.

If the audible alarm sounds intermittently and rapidly and the blue flashing light ① flashes rapidly: The platform can be used, but the secondary protection system "SafeManSystem" is deactivated; consult the maintenance personnel.

NOTE: The audible alarm sounds once and the blue flashing light ① flashes several times when the platform is powered up. This indicates that the secondary protection system is operating correctly.

OPERATION DESCRIPTION

If you are trapped between the pressure sensitive bar ② and a structure A:

- All the controls are stopped and locked.
- The horn sounds intermittently and the blue flashing light ① flashes.
- AUTOMATIC TELESCOPE RETRACTION option: the telescope retracts automatically in less than 4 seconds.
- If you are still trapped between the pressure sensitive bar and the structure:
 - Press and release the reset button ③.

Result:

- The controls are unlocked. Use the controls to free yourself.
- The horn stops sounding and the blue flashing light stops flashing when you are no longer trapped.
- If you are no longer trapped between the pressure sensitive bar and the structure:
 - Press and release the reset button ③.

Result:

- The controls are unlocked.
- The horn stops sounding and the blue flashing light stops flashing.

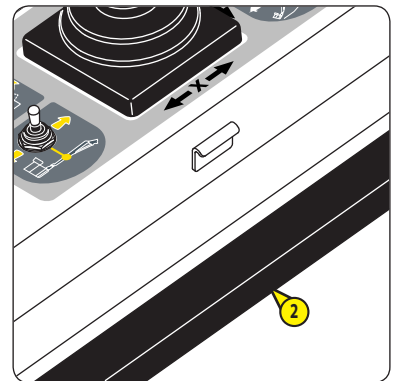

3 - MAINTENANCE

3 - MAINTENANCE

INTRODUCTION	3-3
ORIGINAL MANITOU SPARE PARTS AND EQUIPMENT	3-3
PLATFORM MAINTENANCE	3-4
DAILY AND MONTHLY MAINTENANCE	3-4
COMPULSORY SERVICE AFTER FIRST 500 HOURS OR 6 MONTHS	3-5
PERIODIC MAINTENANCE	3-6
OCCASIONAL MAINTENANCE AND OPERATION	3-8
FILTERING ELEMENTS AND BELTS	3-9
LUBRICANTS AND FUEL	3-10
➡ 10H - DAILY MAINTENANCE OR EVERY 10 HOURS OF SERVICE	3-12
➡ 50H - MONTHLY MAINTENANCE OR EVERY 50 HOURS OF SERVICE	3-22
➡ ① 250H - PERIODIC MAINTENANCE - EVERY 250 HOURS OF SERVICE OR 6 MONTHS	3-28
➡ ② 500H - PERIODIC MAINTENANCE - EVERY 500 HOURS OF SERVICE OR 1 YEAR	3-38
➡ ③ 1000H - PERIODIC SERVICE - EVERY 1000 HOURS OF SERVICE OR 2 YEARS	3-48
➡ ④ 2000H - PERIODIC SERVICE - EVERY 2000 HOURS OF SERVICE OR 4 YEARS	3-53
➡ OCCASIONAL MAINTENANCE	3-54
➡ OCCASIONAL OPERATION	3-58

INTRODUCTION

MAINTENANCE OPERATIONS REQUIRE SPECIFIC PRECAUTIONS.

⚠ IMPORTANT ⚠

Unless specific instructions are given, during maintenance operations:

- The platform must be on a level surface. The wheels must be chocked.

- The platform should be in transport position; the turntable and the basket should be in neutral position, the jib should be completely lowered (⚠ 2 - DESCRIPTION: USE OF THE PLATFORM).

- The basket must be empty.

- If installed, the pipe support must be empty.

- If installed, the panel support must be empty.

ORIGINAL MANITOU SPARE PARTS AND EQUIPMENT

OUR PLATFORMS MUST BE SERVICED USING ORIGINAL MANITOU PARTS.

BY ALLOWING THE USE OF NON ORIGINAL MANITOU PARTS, YOU RISK:

⚠ IMPORTANT ⚠

THE USE OF COUNTERFEIT PARTS OR COMPONENTS NOT APPROVED BY THE MANUFACTURER, MEANS YOU LOSE THE BENEFIT OF THE CONTRACTUAL GUARANTEE.

- Legally, entailing your responsibility in the event of an accident.
- Technically, causing operating malfunctions and reducing the access platform's service life.

USING ORIGINAL MANITOU PARTS FOR MAINTENANCE OPERATIONS MEANS THAT YOU BENEFIT FROM OUR KNOW-HOW

Through its network, MANITOU provides the user with,

- Know-how and competence.
- The guarantee of high-quality work.
- Original replacement parts.
- Help with preventive maintenance.
- Efficient help with diagnosis.
- Improvements due to experience feedback.
- Operator training.
- Only the MANITOU network has detailed knowledge of the design of the access platform and therefore the best technical ability to provide maintenance.

⚠ IMPORTANT ⚠

ORIGINAL REPLACEMENT PARTS ARE DISTRIBUTED EXCLUSIVELY BY MANITOU AND ITS DEALER NETWORK.

The dealer network list is available on the MANITOU web site: www.manitou.com

PLATFORM MAINTENANCE

DAILY AND MONTHLY MAINTENANCE

⚠ IMPORTANT ⚠

**DAILY MAINTENANCE MUST BE CARRIED OUT BY THE OPERATOR BEFORE USING THE PLATFORM.
MONTHLY MAINTENANCE MUST BE CARRIED OUT BY THE QUALIFIED MAINTENANCE PERSONNEL.**

COMPULSORY SERVICE AFTER FIRST 500 HOURS OR 6 MONTHS

⚠ IMPORTANT ⚠

THIS SERVICE MUST BE CARRIED OUT AFTER THE FIRST 500 HOURS OF SERVICE OR WITHIN THE 6 MONTHS FOLLOWING THE PLATFORM BEING PUT INTO SERVICE (WHICHEVER OCCURS FIRST) AND MUST BE PERFORMED BY AN APPROVED PROFESSIONAL FROM THE MANITOU NETWORK.

PERIODIC MAINTENANCE

⚠ IMPORTANT ⚠

THE PERIODIC MAINTENANCE MUST BE CARRIED OUT BY AN APPROVED PROFESSIONAL FROM THE MANITOU NETWORK.

MAINTENANCE SCHEDULE

This schedule enables the periodic maintenance on the platform to be kept up-to-date by reporting the total number of hours worked and the date of the service.

OCCASIONAL MAINTENANCE AND OPERATION

⚠ IMPORTANT ⚠

OCCASIONAL MAINTENANCE OR OPERATIONS MUST BE PERFORMED BY QUALIFIED MAINTENANCE PERSONNEL OR AN APPROVED PROFESSIONAL FROM THE MANITOU NETWORK.

These maintenance operations are to be carried out when needed for the safety and upkeep of the platform.

DAILY AND MONTHLY MAINTENANCE

🔄 10H - DAILY MAINTENANCE OR EVERY 10 HOURS OF SERVICE

- CHECK	General inspection	3-12
- CHECK	Fuel level	3-12
- CHECK	Battery voltage	3-12
- CHECK	Engine oil level	3-13
- CHECK	Coolant level	3-13
- CHECK	Alternator/fan belt	3-14
- CHECK	Hydraulic oil level	3-14
- CHECK	Platform controls	3-15
- CHECK	Secondary protection system "SafeManSystem" (OPTION)	3-20

🔄 50H - MONTHLY MAINTENANCE OR EVERY 50 HOURS OF SERVICE

ALSO PERFORM THE DAILY MAINTENANCE.

- CHECK	Injection pipes, fuel hoses and the hose clamps	3-22
- CHECK	Reduction gearbox impermeability	3-22
- CHECK	Impermeability of the front and rear axle differentials	3-22
- CHECK	Impermeability of the front and rear gear reducers	3-22
- CHECK	Wheel nut tightening	3-23
- CHECK	Remote control unit	3-23
- CHECK	Generator (OPTION)	3-24
- CLEAN	Coolant, air and oil radiators	3-24
- CLEAN	Dry air filter cartridge	3-25
- LUBRICATE	Front and rear axles	3-26
- CHECK	Condition of pipe support (accessory)	3-26
- CHECK	Condition of panel support (accessory)	3-26
- RESET	Maintenance warning	3-26

COMPULSORY SERVICE AFTER FIRST 500 HOURS OR 6 MONTHS

FIRST 500 HOURS BEFORE THE FIRST 6 MONTHS

- If the platform has reached the first 500 hours of service before the first 6 months have expired, perform both the compulsory service and periodic 500-hour maintenance (◀ → ② 500H - PERIODIC MAINTENANCE - EVERY 500 HOURS OF SERVICE OR 1 YEAR).

FIRST 6 MONTHS BEFORE THE FIRST 500 HOURS

- If the platform has not completed 500 hours of service in the first 6 months, carry out only the compulsory service.

MANDATORY SERVICE

- CHECK	General inspection	3-12
- CHECK	Platform controls	3-15
- CHECK	Secondary protection system "SafeManSystem" (OPTION)	3-20
- CHECK	Injection pipes, fuel hoses and the hose clamps	3-22
- CHECK	Reduction gearbox impermeability	3-22
- CHECK	Impermeability of the front and rear axle differentials	3-22
- CHECK	Impermeability of the front and rear gear reducers	3-22
- CHECK	Wheel nut tightening	3-23
- CHECK	Remote control unit	3-23
- CHECK	Generator (OPTION)	3-24
- CLEAN	Coolant, air and oil radiators	3-24
- CLEAN	Dry air filter cartridge	3-25
- LUBRICATE	Front and rear axles	3-26
- CHECK	Condition of pipe support (accessory)	3-26
- CHECK	Condition of panel support (accessory)	3-26
- CHECK	Alternator/fan belt	3-28
- CHECK	Tightening of the fixing screws for the oscillating cylinders	3-28
- CHECK	Tightening of the fixing screws for the axles	3-29
- CHECK	Locking of the front axle oscillating cylinders	3-30
- CHECK	Overload alarm	3-31
- CHECK	Stopping distance and braking on a slope	3-32
- CHECK	Turntable rotation motor oil level	3-32
- CHECK	Emergency controls	3-33
- CLEAN	Fuel filter cartridge	3-33
- LUBRICATE	Shafts, hubs and cylinder rings	3-34
- LUBRICATE	Telescope	3-36
- LUBRICATE	Jib telescope (only for 280 TJ)	3-36
- LUBRICATE	Crown gear	3-37
- CHECK	Jib telescope chocking (only for 280 TJ)	3-38
- CHECK	Telescope setting	3-39
- CHECK	Tightening of the fixing screws on the basket rotation cylinder	3-40
- CHECK	Tightening of the fixing screws for the crown gear	3-40
- CHECK	Tightening of the fixing screws on the turntable rotation motor	3-40
- CHECK	Hydraulic hoses	3-41
- CHECK	Engine silent blocks *	3-52
- CHECK	Engine speeds *	3-52
- CHECK	Valve lash *	3-52
- CHECK	Injectors *	3-52
- CHECK	Hydrostatic transmission circuit pressure *	3-52
- CHECK	Speeds of hydraulic movements *	3-52
- CHECK	Condition of cylinders *	3-52
- CHECK	Condition of electric wiring *	3-52

** Consult your dealer.*

PERIODIC MAINTENANCE

MAINTENANCE SCHEDULE

		↓ OR ↓			
WHEN DUE ➡	250 H or 6 MONTHS	FIRST 6 MONTHS	FIRST 500 HOURS	500 H or 1 YEAR	750 H
PERIODIC MAINTENANCE ➡	①	MANDATORY SERVICE	MANDATORY SERVICE + ②	① + ②	①
MACHINE COUNTER ➡					
DATE OF SERVICING ➡					

WHEN DUE ➡	1000 H or 2 YEARS	1250 H	1500 H or 3 YEARS	1750 H	2000 H or 4 YEARS
PERIODIC MAINTENANCE ➡	① + ② + ③	①	① + ②	①	① + ② + ③ + ④
MACHINE COUNTER ➡					
DATE OF SERVICING ➡					

WHEN DUE ➡	2250 H	2500 H or 5 YEARS	2750 H	3000 H or 6 YEARS	3250 H
PERIODIC MAINTENANCE ➡	①	① + ②	①	① + ② + ③	①
MACHINE COUNTER ➡					
DATE OF SERVICING ➡					

WHEN DUE ➡	3500 H or 7 YEARS	3750 H	4000 H or 8 YEARS	4250 H	4500 H or 9 YEARS
PERIODIC MAINTENANCE ➡	① + ②	①	① + ② + ③ + ④	①	① + ②
MACHINE COUNTER ➡					
DATE OF SERVICING ➡					

WHEN DUE ➡	4750 H	5000 H or 10 YEARS	5250 H	5500 H or 11 YEARS	5750 H
PERIODIC MAINTENANCE ➡	①	① + ② + ③	①	① + ②	①
MACHINE COUNTER ➡					
DATE OF SERVICING ➡					

WHEN DUE ➡	6000 H or 12 YEARS	6250 H	6500 H or 13 YEARS	6750 H	7000 H or 14 YEARS
PERIODIC MAINTENANCE ➡	① + ② + ③ + ④	①	① + ②	①	① + ② + ③
MACHINE COUNTER ➡					
DATE OF SERVICING ➡					

➔ ① 250H - PERIODIC MAINTENANCE - EVERY 250 HOURS OF SERVICE OR 6 MONTHS

ALSO PERFORM THE DAILY MAINTENANCE.

- CHECK	Injection pipes, fuel hoses and the hose clamps	3-28
- CHECK	Reduction gearbox impermeability	3-28
- CHECK	Impermeability of the front and rear axle differentials	3-28
- CHECK	Impermeability of the front and rear gear reducers	3-28
- CHECK	Wheel nut tightening	3-28
- CHECK	Alternator/fan belt	3-28
- CHECK	Tightening of the fixing screws for the oscillating cylinders	3-28
- CHECK	Tightening of the fixing screws for the axles	3-29
- CHECK	Locking of the front axle oscillating cylinders	3-30
- CHECK	Overload alarm	3-31
- CHECK	Stopping distance and braking on a slope	3-32
- CHECK	Turntable rotation motor oil level	3-32
- CHECK	Emergency controls	3-33
- CLEAN	Fuel filter cartridge	3-33
- LUBRICATE	Shafts, hubs and cylinder rings	3-34
- LUBRICATE	Telescope	3-36
- LUBRICATE	Jib telescope (only for 280 TJ)	3-36
- LUBRICATE	Crown gear	3-37
- RESET	Maintenance warning	3-37

➔ ② 500H - PERIODIC MAINTENANCE - EVERY 500 HOURS OF SERVICE OR 1 YEAR

ALSO PERFORM THE DAILY SERVICE AND THE PERIODIC SERVICE AT 250 HOURS OF SERVICE.

- CHECK	Jib telescope chocking (only for 280 TJ)	3-38
- CHECK	Telescope setting	3-39
- CHECK	Tightening of the fixing screws on the basket rotation cylinder	3-40
- CHECK	Tightening of the fixing screws for the crown gear	3-40
- CHECK	Tightening of the fixing screws on the turntable rotation motor	3-40
- CHECK	Hydraulic hoses	3-41
- REPLACE	Alternator/fan belt	3-41
- REPLACE	Fuel pre-filter	3-41
- REPLACE	Fuel filter cartridge	3-42
- REPLACE	Engine oil	3-43
- REPLACE	Engine oil filter	3-43
- REPLACE	Dry air filter cartridge	3-44
- REPLACE	Turntable rotation motor oil	3-45
- REPLACE	Hydraulic pressure filter cartridge	3-45
- REPLACE	Hydrostatic transmission filter cartridge	3-46
- RESET	Maintenance warning	3-46

➔ ③ 1000H - PERIODIC SERVICE - EVERY 1000 HOURS OF SERVICE OR 2 YEARS

ALSO PERFORM THE DAILY SERVICE AND THE PERIODIC SERVICES AT 250 HOURS AND 500 HOURS OF SERVICE.

- CLEAN	Fuel tank	3-48
- REPLACE	Dry air filter safety cartridge	3-48
- REPLACE	Coolant	3-49
- REPLACE	Reduction gearbox oil	3-49
- REPLACE	Front and rear axle differential oil	3-50
- REPLACE	Front and rear wheel reduction gear oil	3-50
- REPLACE	Hydraulic oil	3-51
- CLEAN	Filling filter and suction strainer	3-51
- CHECK	Engine silent blocks *	3-52
- CHECK	Engine speeds *	3-52
- CHECK	Valve lash *	3-52
- CHECK	Injectors *	3-52
- CHECK	Hydrostatic transmission circuit pressure *	3-52
- CHECK	Speeds of hydraulic movements *	3-52
- CHECK	Condition of cylinders *	3-52
- CHECK	Condition of electric wiring *	3-52
- REPLACE	Air intake line and air suction hose *	3-52
- REPLACE	Hoses and hose clamps for the coolant radiator *	3-52
- REPLACE	Injection pipes, fuel hoses and the hose clamps *	3-52
- RESET	Maintenance warning	3-52

** Consult your dealer.*

➔ ④ 2000H - PERIODIC SERVICE - EVERY 2000 HOURS OF SERVICE OR 4 YEARS

ALSO PERFORM THE DAILY SERVICE AND THE PERIODIC SERVICES AT 250 HOURS, 500 HOURS AND 1000 HOURS OF SERVICE.

- CHECK	Coolant and oil radiators *	3-53
- CHECK	Water pump and thermostat *	3-53
- CHECK	Injection pump *	3-53
- CHECK	Alternator and starter *	3-53
- CHECK	Turbocharger *	3-53
- CHECK	injection timing *	3-53
- CHECK	Hydraulic circuit pressures *	3-53
- CHECK	Hydraulic circuit flow rates *	3-53
- CLEAN	Hydraulic oil tank *	3-53
- RESET	Maintenance warning	3-53

** Consult your dealer.*

OCCASIONAL MAINTENANCE AND OPERATION

➔ OCCASIONAL MAINTENANCE

- REPLACE	Wheels	3-54
- BLEED	The fuel supply circuit	3-55
- REPLACE	Fuses/relays	3-56

➔ OCCASIONAL OPERATION

- USE	Swivelling engine plate	3-58
- WINCH	Platform	3-59
- TRANSPORT	Platform	3-60

FILTERING ELEMENTS AND BELTS

➔ 2 500H - PERIODIC MAINTENANCE - EVERY 500 HOURS OF SERVICE OR 1 YEAR



ENGINE OIL FILTER

Part number: 749613

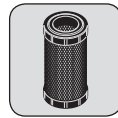

DRY AIR FILTER CARTRIDGE

Part number: 227959



ALTERNATOR/FAN BELT

Part number: 746365

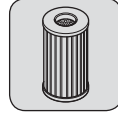

FUEL FILTER CARTRIDGE

Part number: 781909

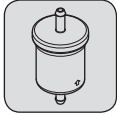

FUEL PRE-FILTER

Part number: 734146

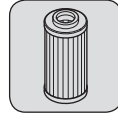

PRESSURE HYDRAULIC FILTER CARTRIDGE

Part number: 518251

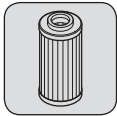

HYDROSTATIC TRANSMISSION FILTER CARTRIDGE

Part number: 518251

➔ 3 1000H - PERIODIC SERVICE - EVERY 1000 HOURS OF SERVICE OR 2 YEARS

ALSO ADD FILTER ELEMENTS AND BELTS FOR PERIODIC MAINTENANCE AFTER 500 HOURS OF SERVICE.

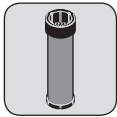

SAFETY DRY AIR FILTER CARTRIDGE

Part number: 227960

➔ OCCASIONAL MAINTENANCE



CAP/HYDRAULIC OIL TANK FILTER

Part number: 832750

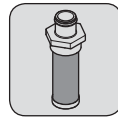

HYDRAULIC OIL TANK SUCTION STRAINER

Part number: 19910

LUBRICANTS AND FUEL

⚠ IMPORTANT ⚠

- USE THE RECOMMENDED LUBRICANTS AND FUEL:**
- For topping up, oils may not be miscible.
 - For oil changes, MANITOU oils are perfectly appropriate.

DIAGNOSTIC ANALYSIS OF OILS

If a service or maintenance contract has been set up with the dealer, a diagnostic analysis of engine, transmission and axle oils may be requested depending on the rate of use.

(*) REQUIRED FUEL SPECIFICATION

Use a high-quality fuel to obtain optimal performance of the engine.

- EN590 diesel fuel (sulphur content < 10 ppm)
- ASTM D975 diesel fuel (sulphur content < 15 ppm)

RECOMMENDATION

ENGINE		
DESCRIPTION	CAPACITY	RECOMMENDATION
		-40 °C -30 °C -20 °C -10 °C 0 °C 10 °C 20 °C 30 °C 40 °C 50 °C
ENGINE OIL	9,5 L	10W30 10W40 MANITOU OIL 15W40 API CH4
		-40 °C -30 °C -20 °C -10 °C 0 °C 10 °C 20 °C 30 °C 40 °C 50 °C
COOLING CIRCUIT	9 L	COOLANT -35 °C
FUEL TANK	72 L	DIESEL GNR HP *

HYDRAULICS		
DESCRIPTION	CAPACITY	RECOMMENDATION
		-40 °C -30 °C -20 °C -10 °C 0 °C 10 °C 20 °C 30 °C 40 °C 50 °C
HYDRAULIC OIL TANK	94 L	ISO VG 100
		ISO VG 68
		MANITOU HYDRAULIC OIL ISO VG 46
		ISO VG 37
		ISO VG 32

TRANSMISSION		
DESCRIPTION	CAPACITY	RECOMMENDATION
		-40 °C -30 °C -20 °C -10 °C 0 °C 10 °C 20 °C 30 °C 40 °C 50 °C
REDUCTION GEAR BOX	0,8 L	MANITOU MECHANICAL TRANSMISSION OIL SAE80W90

FRONT AXLE		
DESCRIPTION	CAPACITY	RECOMMENDATION
		-40 °C -30 °C -20 °C -10 °C 0 °C 10 °C 20 °C 30 °C 40 °C 50 °C
DIFFERENTIAL	7,5 L	SPECIAL MANITOU OIL FOR IMMERSSED BRAKES
WHEEL GEAR REDUCER	2x 0,8 L	MANITOU MECHANICAL TRANSMISSION OIL SAE80W90
STEERING PIVOT PINS		MANITOU BLACK MULTI-PURPOSE LUBRICANT
OSCILLATION BEARINGS		MANITOU BLACK MULTI-PURPOSE LUBRICANT

REAR AXLE									
DESCRIPTION	CAPACITY	RECOMMENDATION							
		-40 °C	-30 °C	-20 °C	-10 °C	0 °C	10 °C	20 °C	30 °C
DIFFERENTIAL	7,5L	SPECIAL MANITOU OIL FOR IMMersed BRAKES							
		-40 °C	-30 °C	-20 °C	-10 °C	0 °C	10 °C	20 °C	30 °C
WHEEL GEAR REDUCER	2x 0,8 L	MANITOU MECHANICAL TRANSMISSION OIL SAE80W90							
		-40 °C	-30 °C	-20 °C	-10 °C	0 °C	10 °C	20 °C	30 °C
STEERING PIVOT PINS		MANITOU BLACK MULTI-PURPOSE LUBRICANT							

LIFTING STRUCTURE									
DESCRIPTION	CAPACITY	RECOMMENDATION							
		-40 °C	-30 °C	-20 °C	-10 °C	0 °C	10 °C	20 °C	30 °C
GENERAL GREASING		MANITOU BLACK MULTI-PURPOSE LUBRICANT							
TELESCOPE LUBRICATION LUBRICATION OF THE JIB TELESCOPE (280 TJ)		MANITOU BLACK MULTI-PURPOSE LUBRICANT							
CROWN GEAR BEARINGS		MANITOU BLACK MULTI-PURPOSE LUBRICANT							
CROWN GEAR TEETH		MANITOU MULTI-PURPOSE EXTREME PRESSURE LUBRICANT							
TURNTABLE ROTATION ENGINE	3L	MANITOU MECHANICAL TRANSMISSION OIL SAE80W90							

PACKAGING

OIL						
PRODUCT	PACKAGING - PART NO.					
	1 LITRE	2 LITRES	5 LITRES	20 LITRES	55 LITRES	209 LITRES
- MANITOU OIL 15W40 API CH4			661706	582357	582358	582359
- MANITOU HYDRAULIC OIL ISO VG 46			545500	582297	546108	546109
- SPECIAL MANITOU OIL FOR IMMersed BRAKES			545976	582391		894257
- MANITOU MECHANICAL TRANSMISSION OIL SAE80W90		499237	720184	546330	546221	546220

GREASE						
PRODUCT	PACKAGING - PART NO.					
	400 ML	400 GR	1 KG	5 KG	20 KG	50 KG
- MANITOU MULTI-PURPOSE EXTREME PRESSURE LUBRICANT	947765					
- MANITOU BLACK MULTI-PURPOSE LUBRICANT		947766	161590			499235

LIQUID						
PRODUCT	PACKAGING - PART NO.					
	1 LITRE	2 LITRES	5 LITRES	20 LITRES	55 LITRES	210 LITRES
- COOLANT -35°C			894967	894968		894969

CHECK

General inspection

⚠ IMPORTANT ⚠

Consult the maintenance personnel if there is doubt about the condition of the platform.

NB: The turntable covers must be opened to carry out the general inspection of the platform. They must be closed once finished.

The operator must perform a visual inspection of the platform:

- Check that the instructions for use are clean and complete.
- Check the stickers and make sure they are all present, clean and legible, 2 - DESCRIPTION: STICKERS.
- Check for the absence of leaks: fuel, engine oil, coolant, battery liquid, hydraulic oil, lubricants, etc.
- Check the condition of the structure: absence of impacts, damage, cracked welding, corrosion, excessive mechanical play, wear, etc.
- Check the condition of the basket: structure, floor, safety rail, harness attachment points, etc.
- Check the condition of the hydraulic components: pumps, distributors, valves, motors, cylinders, hoses, etc.
- Check the condition of the mechanical components: wheels, tyres, tie rods, crown gear, shafts, etc.
- Check the condition of the electrical components: control panels, pedal switch, control handles, switches, buttons, indicator lights, battery, fuses, cables, harnesses, rotating beacon light, etc.
- Check the condition of covers, handles, locks, plugs, etc.
- Check there are no parts missing or loose: screws, nuts, pins, etc.
- Check that no parts are missing or have had unauthorised modifications.
- Check the general cleanliness of the platform: basket floor, motor compartment, etc.

CHECK

Fuel level

CHECK





Battery voltage

⚠ IMPORTANT ⚠

Never smoke or approach with a flame when filling with fuel or when the tank cap has been removed.

Never fill up with fuel while engine is running.

If there is doubt about the battery voltage, refer to the maintenance personnel.

- Switch on the access platform.
- Check the fuel level displayed on the interface screen.
- If the level is low:
 - Open the flap .
 - Remove the cap from the tank .
 - Add fuel until the maximum level is reached, LUBRICANTS AND FUEL.
 - Refit the tank cap and close the flap.
- If the level is correct:
 - Ensure that the tank cap  and the flap  are correctly closed.
- Check the battery voltage displayed on the interface screen. Refer to the maintenance personnel if the voltage is low.
- Switch off the power to the access platform.



CHECK

Engine oil level

- Open the left-hand turntable cover.
- Remove the dipstick ①. Clean it with a clean cloth and put it back in place.
- Remove the dipstick. The level is correct when the engine oil is between the 2 marks A and B.
- If the level is low:
 - Put the dipstick back in place.
 - Remove the filler plug ②.
 - Add engine oil, ↩ LUBRICANTS AND FUEL.
 - Refit the filler cap.
 - Wait for 5 minutes for the oil to settle in the crankcase.
 - Remove the dipstick. Clean it with a clean cloth and put it back in place.
 - Remove the dipstick. The level is correct when the engine oil is between the 2 marks A and B.
 - Put the dipstick back in place.
- If the level is correct:
 - Put the dipstick back in place.
 - Ensure that the filler cap ② is correctly closed.

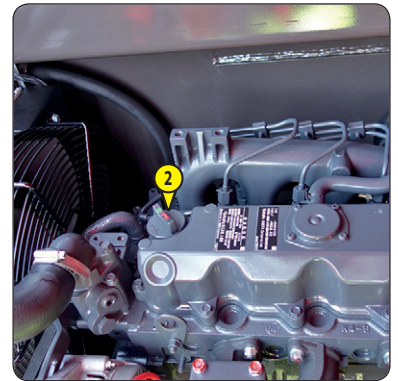
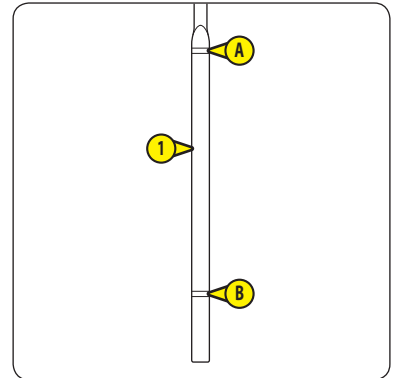
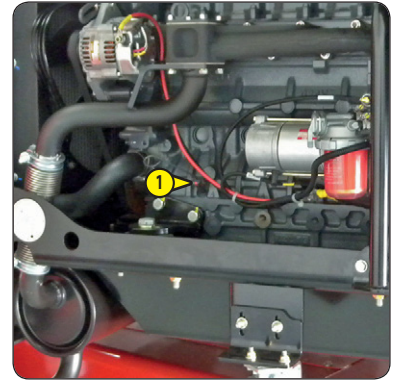

CHECK

Coolant level

⚠ IMPORTANT ⚠

*Wait until the engine cools if it has been running for a while.
Do not remove the radiator cap until the engine is completely cooled.*

- NOTE: The left turntable cover is open.
- Remove the radiator plug ①. The level is correct when the coolant reaches the top of the filling hole.
 - If the level is low:
 - Add coolant until the correct level is reached, ↩ LUBRICANTS AND FUEL.
 - Refit the radiator cap.
 - If the level is correct:
 - Refit the radiator cap.



CHECK

Alternator/fan belt

⚠ IMPORTANT ⚠

If there is doubt about the condition of the belt, refer to the maintenance personnel.

NOTE: The left turntable cover is open.

- Check the condition of the belt ①. Ensure there are no cracks or signs of wear.
- Check the belt tension between the crankshaft pulley and the alternator pulley:
 - Apply pressure with the thumb = 98 N. The clearance ② must be between 7 mm and 9 mm to be correct.
- Adjust if necessary:
 - Refer to the maintenance personnel.
- Close the left-hand turntable cover.

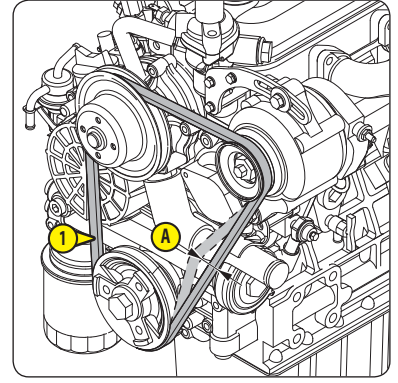

CHECK

Hydraulic oil level

⚠ IMPORTANT ⚠

The platform must be in transport position with the jib lowered completely.

There can be a difference in level of 10 mm to 20 mm between hot and cold oil. It is recommended the level is checked again when the hydraulic oil is hot.

Clean the oil can before adding oil to the hydraulic oil tank.

Use a clean funnel to add oil to the hydraulic oil tank.

- Open the right-hand turntable cover.
- Locate the level indicator ①. The level is correct when the oil reaches the red dot on the level indicator.
- If the level is low:
 - Remove the cap from the tank ②.
 - Add hydraulic oil until the correct level is reached, \triangleleft LUBRICANTS AND FUEL.
 - Refit the tank cap.
- If the level is correct:
 - Ensure that the tank cap ② is correctly closed.
- Close the right-hand turntable cover panel.

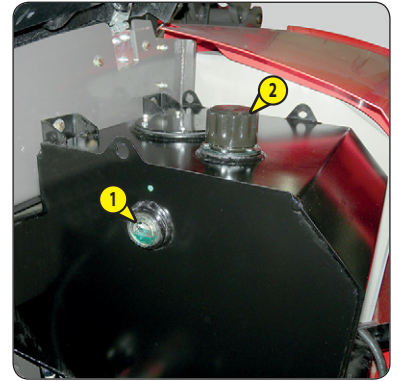

⚠ IMPORTANT ⚠

- ⚠ 2 - DESCRIPTION for more information on the control panels on the ground and in the basket.
 Select a test area on a firm, level surface that is free of any obstacles.
 Look around and above you when manoeuvring the platform (lifting, rotation, etc.).
 Pay particular attention to electric lines and any object that may be within the platform's field of operation.
 Shut the platform down if a malfunction is detected.

STARTING THE ENGINE AND EMERGENCY STOP**GROUND LEVEL CONTROL PANEL:**

- Switch on the access platform.

Result:

- The start-up page, then the preheat page should be displayed on the user interface screen.
- The audible alarm should sound once.

- Wait for the preheat cycle to finish and start up the engine.

Result:

- The engine should start.

- Press the emergency stop button.

Result:

- The emergency stop button should be locked in the OFF position.
- The engine should stop.
- It should not be possible to activate the controls.

- Turn the emergency stop button a quarter turn to the right and release it.

Result:

- The emergency stop button should be unlocked (in the ON position).
- The start-up page, then the preheat page should be displayed on the user interface screen.

- Wait for the preheat cycle to finish and start up the engine.

Result:

- The engine should start.

CONTROL PANEL IN THE BASKET:

- Turn the basket to the right or left, at the same time pressing the emergency stop button.

Result:

- The emergency stop button should be locked in the OFF position.
- The basket rotation should stop.
- The engine should stop.
- It should not be possible to activate the controls.

- Turn the emergency stop button a quarter turn to the right and release it.

Result:

- The emergency stop button should be unlocked (in the ON position).
- The preheat light should light up.

- Wait for the preheat cycle to finish and start up the engine.

Result:

- The engine should start.

HORN

NOTE: The engine has been started.

CONTROL PANEL IN THE BASKET:

- Press horn button and release it.

Result:

- The horn should sound.

OVERLOAD ALARM

⚠ IMPORTANT ⚠

The PIPE SUPPORT or PANEL SUPPORT accessories must be removed before checking the overload alarm, 4 - ACCESSORIES.

NOTE: The engine has been started.

CONTROL PANEL ON THE GROUND AND IN THE BASKET:

- Place a uniformly distributed weight in the basket:
 - 260 TJ: Put between 440 kg and 475 kg.
 - 280 TJ: Put between 385 kg and 415 kg.

Result:

- The overload alarm should go off.
- Try to operate the platform controls from the ground control panel and then from the control panel in the basket.

Result:

- It should not be possible to activate the controls.
- Remove the entire load from the basket.

Result:

- The overload alarm should stop.

NOTE: End of test for 260 TJ.

280 TJ:

- Enter the basket.

Result:

- The restricted capacity warning light must be off.
- Raise the jib to the horizontal position.
- Fully extend the jib telescope.
- Fully extend the telescope.

Result:

- The restricted capacity warning light should flash.
- Lower the jib.
- Get out of the basket.
- Place a uniformly distributed weight in the basket:
 - Place between 264 kg and 294 kg less the operator's weight.
- Enter the basket.

Result:

- The overload alarm should go off.
- The restricted capacity warning light should come on.
- Try to operate the platform controls from the control panel in the basket.

Result:

- It should not be possible to activate the controls.
- Get out of the basket.

Result:

- The overload alarm should stop.
- Retract the telescope for 10 seconds from the ground level control panel.
- Enter the basket.

Result:

- The restricted capacity warning light should remain on.
- Extend the telescope.

Result:

- The telescope should not extend completely.
- Lower the jib.
- Get out of the basket.
- Remove the entire load from the basket.

CONTROLS: TURNABLE ROTATION, MAIN JIB, X-Y FUNCTIONS, TELESCOPE, JIB, JIB TELESCOPE (280 TJ), BASKET/JIB TILT, BASKET TILT (280 TJ) AND BASKET ROTATION

NOTE: The engine has been started.

GROUND LEVEL CONTROL PANEL:

- Do not touch the selector switch on the controls at ground level/in the basket. Test the controls one by one.

Result:

- It should not be possible to activate any of the controls.

- Press and hold down the selector switch for the ground controls/in the basket on the right . Test the controls one by one.

Result:

- It should be possible to activate all the controls.

- Put the platform in the transport position. Put the turntable and basket in the neutral position. Lower the jib completely.

CONTROL PANEL IN THE BASKET:

- Do not touch the foot switch. Test the controls one by one.

Result:

- It should not be possible to activate any of the controls.

- Press and hold down the foot switch. Test the controls one by one.

Result:

- It should be possible to activate all the controls.

- Put the machine in transport position. Put the turntable and basket in neutral position.

CONTROLS: DRIVING/BRAKING/STEERING (TRANSPORT POSITION)

NOTE: The engine has been started.

CONTROL PANEL IN THE BASKET:

- Raise the jib slightly for good visibility.

- Select TORTOISE speed .

- Do not touch the foot switch. Do not touch the control handle trigger. Try to drive and steer the platform.

- Do not touch the foot switch. Press and hold down the control handle trigger. Try to drive and steer the platform.

- Press and hold down the foot switch. Do not touch the control handle trigger. Try to drive and steer the platform.

Result:

- It should not be possible to activate the controls.

- Press and hold down the foot switch. Press and hold down the control handle trigger.

- Drive the platform forward, steer left/right and brake. Reverse the platform and brake.

- Select RAMP speed  and perform the test again.

- Select HARE speed  and perform the test again.

Result:

- Driving and steering should function properly.

- Brakes should function properly.

- Test 4-WHEEL, 2-WHEEL and CRAB steering modes, at TORTOISE speed .

Result:

- The steering modes should function properly.

- The wheel alignment indicator lights should function properly.

TURNABLE ORIENTATION MORE THAN 90° INDICATOR LIGHT

NOTE: The engine has been started. TORTOISE speed  is selected.

- Turn the turntable to the left more than 90° relative to the neutral position.

Result:

- The light indicating turntable orientation of more than 90° should be lit.
- Turn the turntable to the right more than 90° relative to the neutral position.

Result:

- The light indicating turntable orientation of more than 90° should be lit.
- Place the turntable in the neutral position.

UPPER ARM AND TELESCOPE POSITION SENSORS

NOTE: The engine has been started.

CONTROL PANEL IN THE BASKET:

- Select TORTOISE speed .
- Drive the platform forward for a short distance. Assess and remember the speed of the platform.
- Raise the main jib for 3 seconds.
- Drive the platform forward for a short distance.

Result:

- The driving speed must be the WORKING POSITION speed. Assess and remember the speed of the platform.
- Fully lower the main jib.
- Drive the platform forward for a short distance.

Result:

- The driving speed must be TORTOISE speed .
- Extend the telescope for 3 seconds.
- Drive the platform forward for a short distance.

Result:

- The driving speed must be WORKING POSITION speed.
- Fully retract the telescope.
- Drive the platform forward for a short distance.

Result:

- The driving speed must be TORTOISE speed .

SLOPE ALARM

NOTE: The engine has been started.

GROUND LEVEL CONTROL PANEL:

- Open the right-hand turntable cover.
- Locate the levelling sensor ① (first version) or ② (second version).
- Press the levelling sensor so that it is tilted and hold it down.

Result:

- The tilt alarm should go off.
- Levelling sensor ① (first version): the yellow light must come on.

NOTE: The red light must stay on.

- Levelling sensor ② (second version): the light must go out.

- Release the levelling sensor.

Result:

- The tilt alarm should stop.
- Levelling sensor ① (first version): the yellow light must go off.

NOTE: The red light must stay on.

- Levelling sensor ② (second version): the light must come on.

CONTROL PANEL IN THE BASKET:

- Raise the main jib for 3 seconds.



- Select RAMP speed
- Select a slope between 15% (8.5°) and 25% (14°).
- Drive the platform forwards slowly on the slope, facing it, with the basket at the bottom of the slope.
- Drive the platform onto the slope.

Result:

- The platform should brake automatically.
- The tilt alarm should go off.

- 260 TJ: Try to raise the main jib, extend the telescope and drive/operate.
- 280 TJ: Try to raise the main jib, extend the telescope, extend the jib telescope, tilt the basket upwards/downwards and drive/operate.

Result:

- It should not be possible to activate the controls.

- Fully lower the main jib.

Result:

- It should be possible to activate the control.

- Drive the platform off the slope to a level surface.

Result:

- The tilt alarm should stop.

- Stop the engine. Power down the platform.

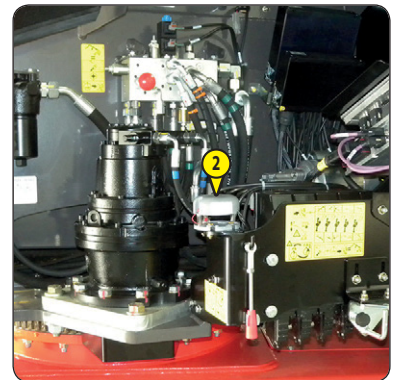
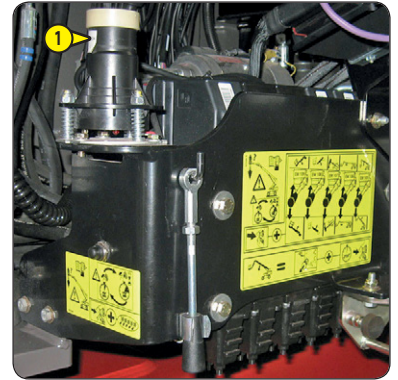

CHECK

Secondary protection system "SafeManSystem" (OPTION)

⚠ IMPORTANT ⚠

Select a test area on a firm, level surface that is free of any obstacles.
Shut the platform down if a malfunction is detected.

- Switch on the access platform.

Result:

- The audible alarm should sound once.
- The blue flashing light ① should flash several times and stop.

NOTE: If the safety edge ② is defective, the blue flashing light ① flashes rapidly and the audible alarm sounds intermittently. The platform can function normally, but the "SafeManSystem" option is deactivated.

- Get into the basket and start the engine.

- Extend the telescope for 5 seconds.

- Turn the basket to the right or left, at the same time pressing the safety edge ② and release it.

Result:

- The basket rotation should stop.
- The horn should sound intermittently and the blue flashing light should flash.
- It should not be possible to activate the controls.
- AUTOMATIC TELESCOPE RETRACTION option: the telescope should retract automatically in less than 4 seconds.

- Press and release the reset button ③.

Result:

- The horn should stop sounding and the blue flashing light should stop flashing.
- It should be possible to activate the controls.

- Extend the telescope for 5 seconds.

- Turn the basket to the right or left, at the same time pressing the safety edge ② and hold it down.

Result:

- The basket rotation should stop.
- The horn should sound intermittently and the blue flashing light should flash.
- It should not be possible to activate the controls.
- AUTOMATIC TELESCOPE RETRACTION option: the telescope should retract automatically in less than 4 seconds.

- Hold the safety edge ② down, press the reset button ③ and release it.

Result:

- The horn and the blue flashing light should continue to operate.
- It should be possible to activate the controls.

- Release the safety edge.

Result:

- The horn should stop sounding and the blue flashing light should stop flashing.
- Put the platform in the transport position. Put the turntable and basket in the neutral position. Lower the jib completely.
- Get out of the basket.
- Stop the engine. Power down the platform.

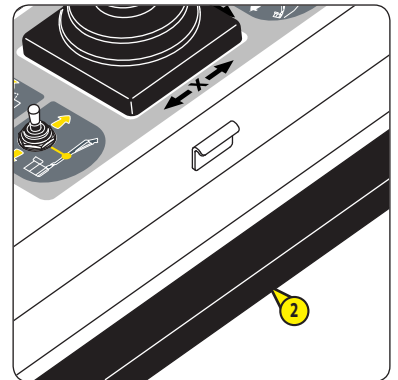

50H - MONTHLY MAINTENANCE OR EVERY 50 HOURS OF SERVICE

ALSO PERFORM THE DAILY MAINTENANCE.

CHECK

Injection pipes, fuel hoses and the hose clamps

⚠ IMPORTANT ⚠

Never smoke or approach with a flame during this check.

If there is doubt about the condition of the injection pipes, fuel hoses and hose clamps, have them replaced by an authorised professional from the Manitou network.

- Open the left-hand turntable cover.
- Open the swivelling engine plate, \triangleleft OCCASIONAL OPERATION.
- Check the condition of all the injection pipes, fuel hoses and the tightening clamps.
- Check for fuel leaks.
- Close the swivelling engine plate, \triangleleft OCCASIONAL OPERATION.
- Close the left-hand turntable cover.

CHECK

Reduction gearbox impermeability

- Locate the reduction gearbox ① on the rear axle.
 - Check no oil is leaking from the reduction gearbox and plugs.
 - If a leak is detected:
 - Clean the outside of the reduction gearbox with a clean cloth.
 - Remove the filler plug ②.
- NOTE: 2 filler caps (left and right sides).
- Check that the oil reaches the filling hole.
 - Add oil if necessary, \triangleleft LUBRICANTS AND FUEL.
 - Refit the filler cap.

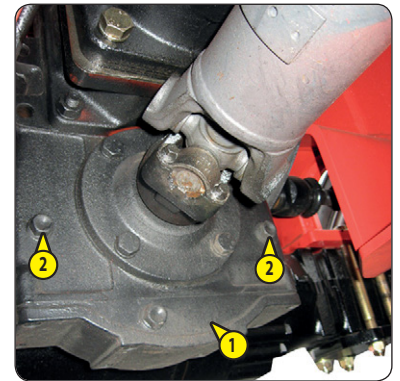

CHECK

Impermeability of the front and rear axle differentials

- Check no oil is leaking from the differentials and plugs.
- If a leak is detected:
 - Clean the outside of the axle differential with a clean cloth.
 - Remove the level plug ①.
 - Check that the oil reaches the hole.
 - Remove the filler cap ② and add oil if necessary, \triangleleft LUBRICANTS AND FUEL.
 - Refit the level plugs and filler cap.

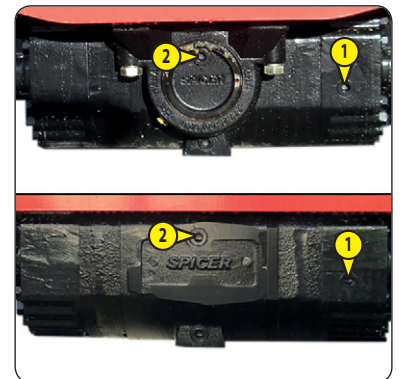

CHECK

Impermeability of the front and rear gear reducers

- NOTE: Check the gear reducers one by one.
- Check no oil is leaking from the gear reducers and plugs.
 - If a leak is detected:
 - Turn the wheel to put the drain/filler plug ① in the horizontal position.
 - Clean the outside of the gear reducer with a clean cloth.
 - Remove the drain/filler plug.
 - Check that the oil reaches the filling hole.
 - Add oil if necessary, \triangleleft LUBRICANTS AND FUEL.
 - Refit the drain/filler plug:
- Tightening torque = 42 Nm \pm 7 Nm



⚠ IMPORTANT ⚠

Failure to comply with this instruction may damage the wheel nuts and distort the wheels.

- Check all the wheel nut tightening torques:
 - 550 N ± 55 N

⚠ IMPORTANT ⚠

⚠ 2 - DESCRIPTION for more information on the remote control unit.

Select a test area on a firm, level surface that is free of any obstacles.

Look around and above you when manoeuvring the platform.

Pay particular attention to electric lines and any object that may be within the platform's field of operation.

Shut the platform down if a malfunction is detected.

EMERGENCY STOP AND STARTING THE ENGINE (depending on the version)

- Switch on the machine.
- Start the engine from the ground control panel.

REMOTE CONTROL UNIT (all versions):

- Press the emergency stop button.

Result:

- The emergency stop button should be locked in the OFF position.
- The engine should stop.
- It should not be possible to activate the controls.
- First and second version: Turn the button a quarter turn to the right and release it.
- Third version: Pull the button or turn it a quarter turn to the right and release it.
- Turn the emergency stop button a quarter turn to the right and release it.

Result:

- The emergency stop button should be unlocked (in the ON position).
- The start-up page, then the preheat page should be displayed on the user interface screen.

REMOTE CONTROL UNIT (first and second version):

- Start the engine from the ground control panel.

REMOTE CONTROL UNIT (third version):

- Wait for the preheat cycle to finish and start up the engine.

Result:

- The engine should start.

CONTROLS: MAIN JIB AND BASKET/JIB TILT

NOTE: The engine has been started.

REMOTE CONTROL UNIT (all versions):

- Do not touch the activation button. Test the controls one by one.

Result:

- It should not be possible to activate any of the controls.
- Press and hold down the activation button. Test the controls one by one.

Result:

- It should be possible to activate all the controls.
- Place the platform in the transport position.
- Stop the engine. Power down the platform.

CHECK

Generator (OPTION)

NOTE: Refer to the sticker in the basket for the voltage and intensity supplied by the electric power socket.

- Switch on the platform. Start the engine.
- Start the generator.
- Plug an electrical appliance into the electric power socket in the basket.

Result:

- The electrical appliance should operate.

- Open the cover **A**.
- Locate the test button **1** on the generator and press it.

Result:

- The switch **2** must move from the ON position to the OFF position, the indicator **3** should be red.
- The electrical appliance should not operate.

- Push the switch to the ON position.

Result:

- The switch must remain in the ON position, the indicator should be green.
- The electrical appliance should operate.

- Disconnect the electrical appliance.
- Stop the generator.
- Close the cover **A**.
- Stop the engine. Power down the platform.

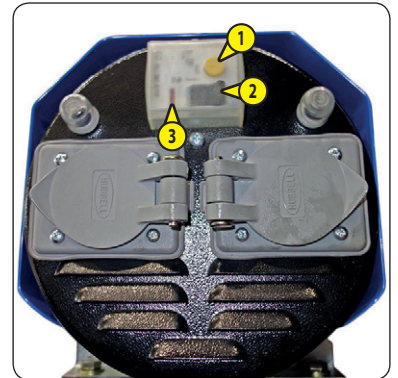
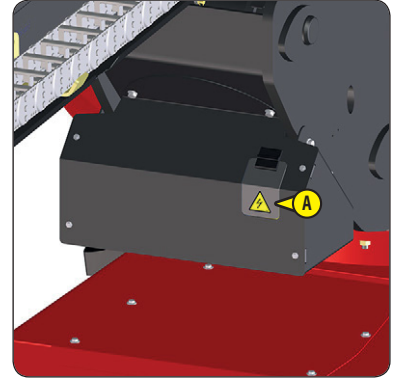

CLEAN

Coolant, air and oil radiators

⚠ IMPORTANT ⚠

Clean the radiators more often when the platform is operating in a dusty environment.

If there is doubt about the condition of the hoses and hose clamps for the coolant and air radiators, it is essential to have them replaced by an authorised professional from the Manitou network.

- Open the left-hand turntable cover.
- Open the swivelling engine plate, ⚠ OCCASIONAL OPERATION.
- Clean the radiators **1** with a small brush to remove the dust.
- Clean them with compressed air, from the inside out.
- Check the condition of the hoses and tightening clamps for the coolant and air radiators.
- Check the condition of the oil radiator.
- Close the swivelling engine plate, ⚠ OCCASIONAL OPERATION.



⚠ IMPORTANT ⚠

Clean the dry air filter cartridge more often when the platform is operating in a dusty environment. If there is doubt about its condition, have it replaced by an approved professional from the Manitou network.

Never use the platform with a damaged air filter unit. If there is doubt about its condition, have it replaced by an approved professional from the Manitou network.

Never use the platform without a dry air filter cartridge or if it is damaged. If there is doubt about its condition, have it replaced by an approved professional from the Manitou network.

Never use the platform without a dry air filter safety cartridge or if it is damaged. If there is doubt about its condition, have it replaced by an approved professional from the Manitou network.

If there is doubt about the condition of the air intake line, the air suction outlet hose and hose clamps, have them replaced by an authorised professional from the Manitou network.

NOTE: The left turntable cover is open.

- Clean the outside of the air filter unit **1** with a clean, slightly damp cloth.
- Unlock and remove the cover of the air filter unit **2**.
- Clean the inside of the air filter unit cover with a clean, slightly damp cloth.
- Remove the valve **3** and clean it.
- Check the condition of the valve and replace it if it is damaged.
- Put the valve back in place.
- Remove the dry air filter cartridge **4** pulling it gently to prevent dust dispersion.

NOTE: Do not press the centre of the dry air filter cartridge.

- Check the condition of the dry air filter safety cartridge **5** without taking it out.
- Check the condition of the air filter unit, the air intake line, the air suction outlet hose and the tightening clamps.
- Clean the dry air filter cartridge **4** by tapping it gently.

NOTE: If necessary clean it with dry compressed air, from the inside out:

- Maximum pressure = 2 bars. Minimum distance = 30 mm.

- Check its condition and clean its seal with a clean cloth.
- Refit it pushing gently.

NOTE: Do not press the centre of the dry air filter cartridge.

- Refit the air filter unit cover **2**, the valve **3** facing downwards, the marking "TOP" facing upwards.
- Close the left-hand turntable cover.

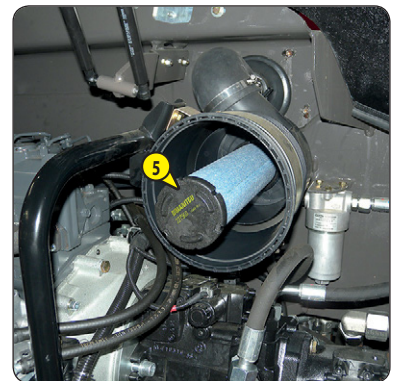
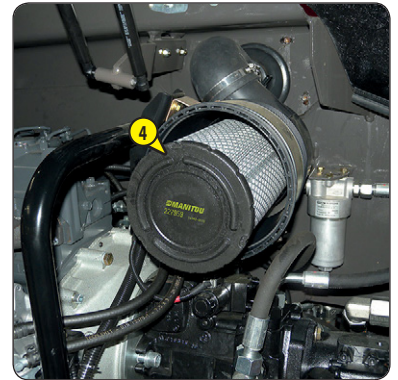
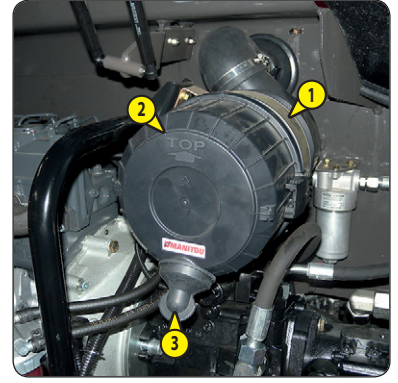

⚠ IMPORTANT ⚠

Lubricate the axles more often when the platform is operating in a dusty environment.

STEERING PIVOT PINS

- Remove the caps from the lubrication connectors ① on the steering pivots of the front and rear axles, on the right and left-hand sides.
- Inject the lubricant into the lubrication connectors, LUBRICANTS AND FUEL.
- Refit the caps.

OSCILLATING FRONT AXLE:

- Remove the caps from the lubrication connectors ② on the front axle oscillating bearings.
- Inject the lubricant into the lubrication connectors, LUBRICANTS AND FUEL.
- Refit the caps.

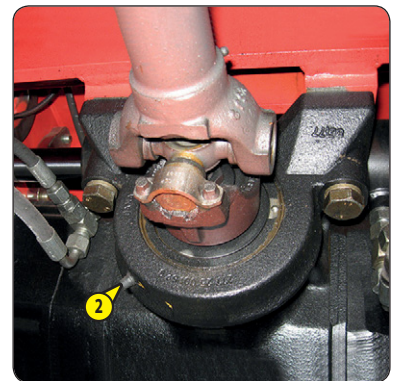
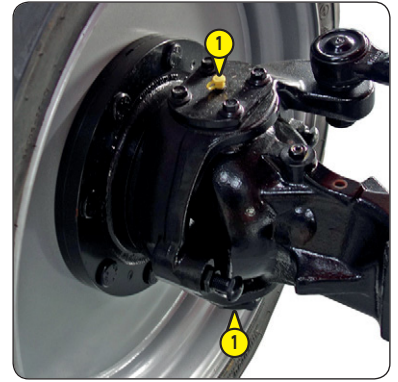

CHECK

Condition of pipe support (accessory)

- Check the general condition of the components, the conformity of the installation and the tightening torques (4 - ACCESSORIES: PIPE SUPPORT).



CHECK

Condition of panel support (accessory)

- Check the general condition of the components, the conformity of the installation and the tightening torques (4 - ACCESSORIES: PANEL SUPPORT).

RESET

Maintenance warning

- Switch on the access platform.
- Refer to 2 - DESCRIPTION: DEFINITION OF SUB-MENUS:
 - Enter in the menu, CODE  .
 - Enter the access code.
 - Enter in the menu, MAINTENANCE  .
 - Zero the corresponding maintenance alerts.
 - Press the MENU key  twice to return to the WORK PAGE.
- Switch off the power to the access platform.

➔ 1 250H - PERIODIC MAINTENANCE - EVERY 250 HOURS OF SERVICE OR 6 MONTHS

ALSO PERFORM THE DAILY MAINTENANCE.

CHECK

Injection pipes, fuel hoses and the hose clamps

⚠ 50H: MONTHLY MAINTENANCE OR EVERY 50 HOURS OF SERVICE.

CHECK

Reduction gearbox impermeability

⚠ 50H: MONTHLY MAINTENANCE OR EVERY 50 HOURS OF SERVICE.

CHECK

Impermeability of the front and rear axle differentials

⚠ 50H: MONTHLY MAINTENANCE OR EVERY 50 HOURS OF SERVICE.

CHECK

Impermeability of the front and rear gear reducers

⚠ 50H: MONTHLY MAINTENANCE OR EVERY 50 HOURS OF SERVICE.

CHECK

Wheel nut tightening

⚠ 50H: MONTHLY MAINTENANCE OR EVERY 50 HOURS OF SERVICE.

CHECK

Alternator/fan belt

⚠ IMPORTANT ⚠

If there is doubt about the condition of the belt, ⚠ 500H: REPLACE: ALTERNATOR/FAN BELT.

- Open the left-hand turntable cover.
- Check the condition of the belt ①. Ensure there are no cracks or signs of wear.
- Check the belt tension between the crankshaft pulley and the alternator pulley:
 - Apply pressure with the thumb = 98 N. The clearance ② must be between 7 mm and 9 mm to be correct.
- Adjust if necessary:
 - Loosen the screws ②.
 - Adjust the belt tension by swivelling the alternator.
 - Tighten the screws ②.
 - Check the belt tension again.
- Close the left-hand turntable cover.

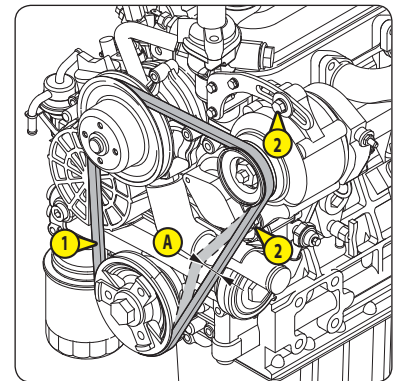

CHECK

Tightening of the fixing screws for the oscillating cylinders

⚠ IMPORTANT ⚠

The tightening of the screws should be checked at the latest after the first 50 hours of service, then every 250 hours of service.

- *Not observing this instruction may cause failure of the fixing screws and damage to the oscillating cylinders.*
- Remove the right and left covers ①.
- Check the tightening torques for all the screws ②, left and right-hand sides:
 - 407 N ± 40 N
- Refit the right and left covers.

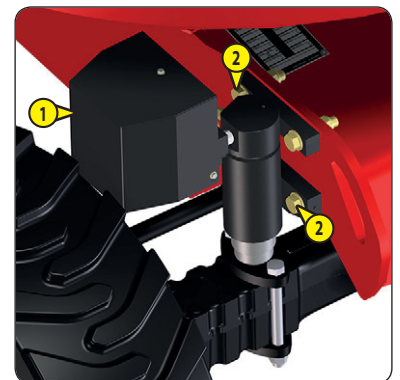

CHECK

Tightening of the fixing screws for the axles

⚠ IMPORTANT ⚠

The tightening of the screws should be checked at the latest after the first 50 hours of service, then every 250 hours of service.

Not observing this instruction may cause failure of the fixing screws and damage to the axles.

- Check all the fixing screw tightening torques:

- ① (Front axle, left and right sides) = $280 \text{ N} \pm 28 \text{ N}$
- ② (Front axle oscillating bearings) = $407 \text{ N} \pm 40 \text{ N}$
- ③ (Rear axle, left and right sides) = $280 \text{ N} \pm 28 \text{ N}$

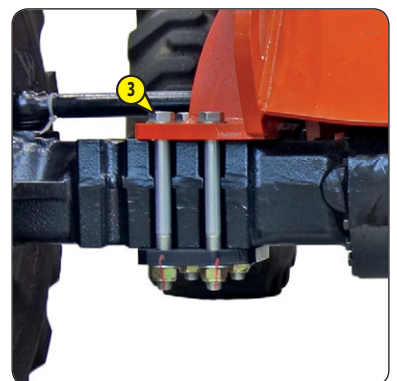
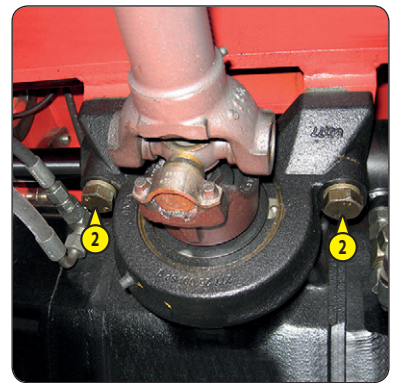
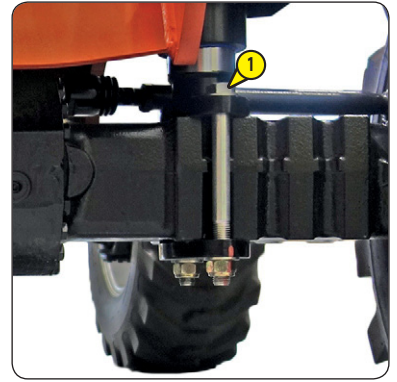

- Place a sufficiently solid ramp in front of the right front wheel:
 - A = 7.5 cm minimum, 9 cm maximum.
 - B = 60 cm maximum.
 - C = 75 cm minimum, 100 cm maximum.
 - D = 10° minimum, 25° maximum.
- Switch on the platform. Start the engine.
- Enter the basket.
- Raise the jib slightly.
- Drive the platform slowly forwards until the right front wheel is at the top of the ramp. Brake the platform.
- Turn the turntable 90° to the left.
- Extend the telescope for 2 seconds.
- Drive the platform slowly backwards until the wheel is off the slope. Brake the platform.
- Ask someone on the ground to check the right front wheel and the oscillating cylinders.

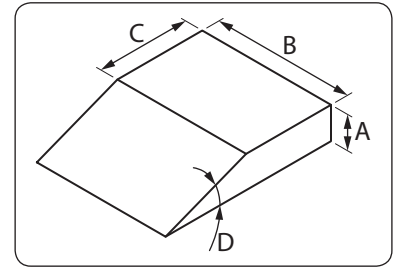

Result:

- The right front wheel should be in the upper position and not in contact with the ground.
- The right oscillating cylinder should be retracted and the left one extended.
- Ask the person on the ground to move away.
- Fully retract the telescope.
- Ask the person on the ground to check the front wheels.

Result:

- The two front wheels must be in contact with the ground.
- Place the turntable in the neutral position.
- Fully lower the jib.
- Get out of the basket.
- Place the same ramp in front of the left front wheel.
- Enter the basket.
- Raise the jib slightly.
- Drive the platform slowly forwards until the left front wheel is at the top of the ramp. Brake the platform.
- Turn the turntable 90° to the right.
- Extend the telescope for 2 seconds.
- Drive the platform slowly backwards until the wheel is off the slope. Brake the platform.
- Ask the person on the ground to check the left front wheel and the oscillating cylinders.

Result:

- The left front wheel should be in the upper position and not in contact with the ground.
- The left oscillating cylinder should be retracted and the right one extended.
- Ask the person on the ground to move away.
- Fully retract the telescope.
- Ask the person on the ground to check the front wheels.

Result:

- The two front wheels must be in contact with the ground.
- Place the turntable in the neutral position.
- Fully lower the jib.
- Get out of the basket.
- Stop the engine. Power down the platform.

⚠ IMPORTANT ⚠

The PIPE SUPPORT or PANEL SUPPORT accessories must be removed before checking the overload alarm, 4 - ACCESSORIES.

NOTE: The platform is in the transport position. The turntable and the basket should be in the neutral position. The jib is completely lowered.

- Switch on the platform. Start the engine.
- Place a uniformly distributed weight in the basket:
 - 260 TJ: put 440 kg.
 - 280 TJ: put 385 kg.

Result:

- The overload alarm should go off.
- Remove part of the load in the basket:
 - 260 TJ: Remove 40 kg to obtain a load of 400 kg.
 - 280 TJ: Remove 35 kg to obtain a load of 350 kg.

Result:

- The overload alarm should stop.
- Remove the entire load from the basket.

NOTE: End of test for 260 TJ.

280 TJ:

- Enter the basket.

Result:

- The restricted capacity warning light must be off.
- Raise the jib to the horizontal position.
- Fully extend the jib telescope.
- Fully extend the telescope.

Result:

- The restricted capacity warning light should flash.
- Lower the jib.
- Get out of the basket.
- Place a uniformly distributed 264 kg weight in the basket.

Result:

- The overload alarm should go off.
- Remove 24 kg to obtain a load of 240 kg in the basket.

Result:

- The overload alarm should stop.
- Remove the entire load from the basket.

CHECK

Stopping distance and braking on a slope

NOTE: The engine has been started. The platform is in the transport position. The turntable and the basket are in neutral position. The jib is completely lowered.



- Place a uniformly distributed weight in the basket:
 - 260 TJ: without accessorie. Put 400 kg less the operator's weight.
 - 260 TJ: with an accessorie installed (pipe support or panel support). Put 385 kg less the operator's weight.
 - 280 TJ: without accessorie. Put 350 kg less the operator's weight.
 - 280 TJ: with an accessorie installed (pipe support or panel support). Put 335 kg less the operator's weight.

STOPPING DISTANCE ON LEVEL GROUND

- Drive the platform forward, reach maximum speed and then release the joystick to stop the platform.
- Required results:

	Stopping distance
Transport position: HARE speed 	1,400 mm ± 300 mm
Working position: WORKING POSITION speed	200 mm ± 50 mm

CHECKING THE BRAKES ON A SLOPE

- Place the platform in the transport position.
- Raise the jib slightly. 
- Select RAMP speed 
- Drive the platform forwards slowly on a 25% (14°) slope, facing it, with the basket at the bottom of the slope.
- Brake the platform on the slope. Stop the engine.

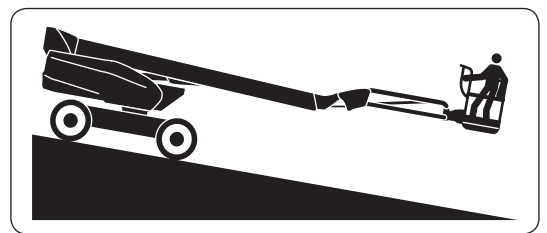

Result:

- The platform must not have moved back after one minute.
- Switch on the engine.
- Drive the platform off the slope to a level surface.
- Fully lower the jib.
- Remove the entire load from the basket.
- Stop the engine. Power down the platform.

CHECK

Turntable rotation motor oil level

- Open the right-hand turntable cover.
- Check no oil is leaking from the turntable rotation motor ①.
- Remove the filler plug ②.
- Clean the gauge on the filler cap with a clean cloth and put it back in place.
- Remove the filler cap. The level is correct when the oil is between the 2 marks A and B.
- If the level is low:
 - Add oil until the correct level is reached, LUBRICANTS AND FUEL.
 - Refit the filler cap.
- If the level is correct:
 - Refit the filler cap.
- Close the right-hand turntable cover panel.

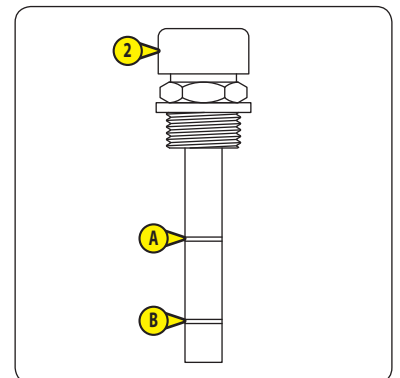
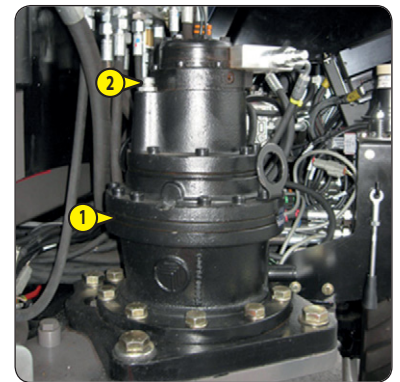

⚠ IMPORTANT ⚠

Use of the platform if there is a malfunction is prohibited.

- Check that the emergency controls are working, 2 - DESCRIPTION: RESCUE PROCEDURE.

CLEAN

Fuel filter cartridge

⚠ IMPORTANT ⚠

Never smoke or approach with a flame when the fuel filter cartridge is being cleaned.

Never use the platform without the fuel filter cartridge or if it is damaged. If there is doubt about its condition,

 500H: REPLACE: FUEL FILTER CARTRIDGE.

- Open the left-hand turntable cover.
- Clean the outside of the fuel filter **1** with a clean cloth.
- Turn the tap **2** to the position **OFF**.
- Unscrew the retaining ring **3**.
- Remove the tank **4** and the fuel filter cartridge **5**. Clean them with clean fuel, LUBRICANTS AND FUEL.
- Check their condition.
- Check the condition of the fuel hoses and the hose clamps.
- Refit the fuel filter cartridge, tank and retaining ring.
- Bleed the fuel supply circuit OCCASIONAL MAINTENANCE.
- Close the left-hand turntable cover.

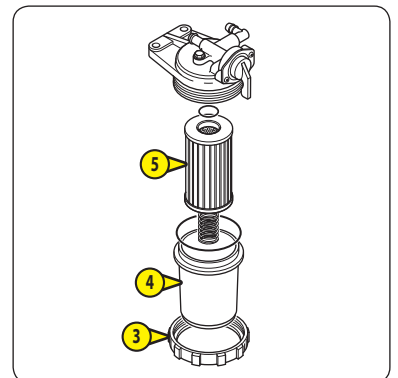
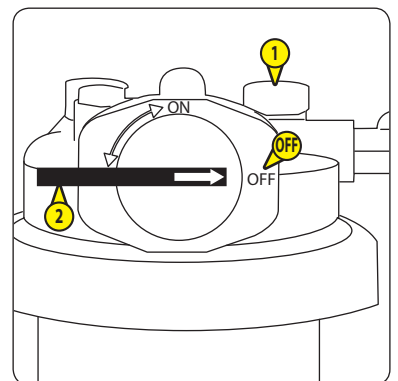
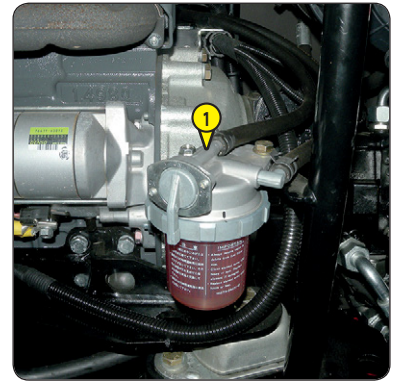

- Remove the caps of the lubrication connectors.
- Inject the lubricant into each lubrication connector, \blacktriangleleft LUBRICANTS AND FUEL.
- Refit the caps of the lubrication connectors.

KEY

SHAFT

HUB

CYLINDER RING

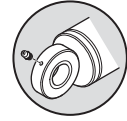
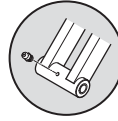
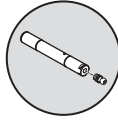

260 TJ

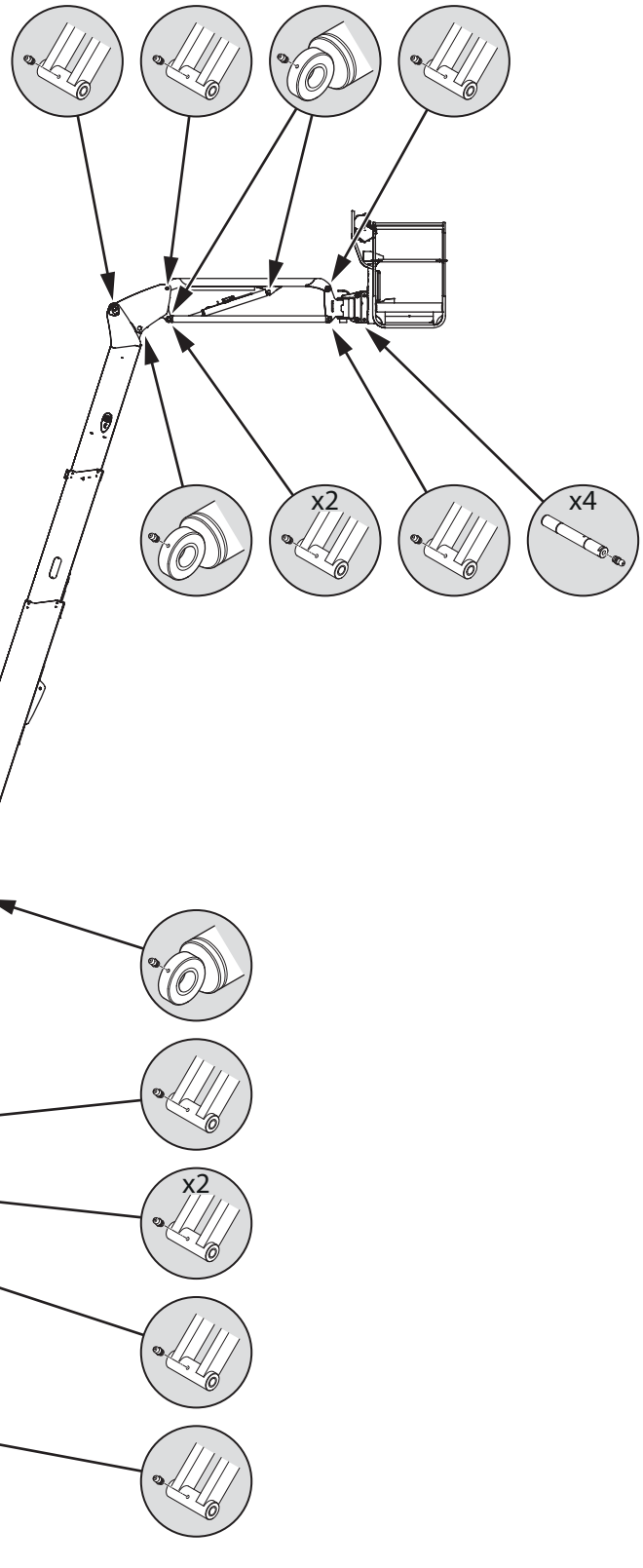

\blacktriangleleft 2 - DESCRIPTION: STICKERS: REMOTE LUBRICATION.

NOTE: (A) and (B)

\blacktriangleleft LUBRICATE: RING GEAR.

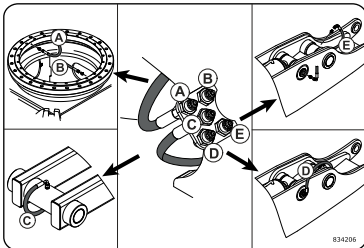

KEY

SHAFT

HUB

CYLINDER RING

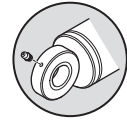
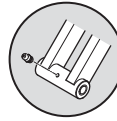
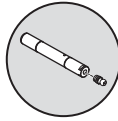

280 TJ

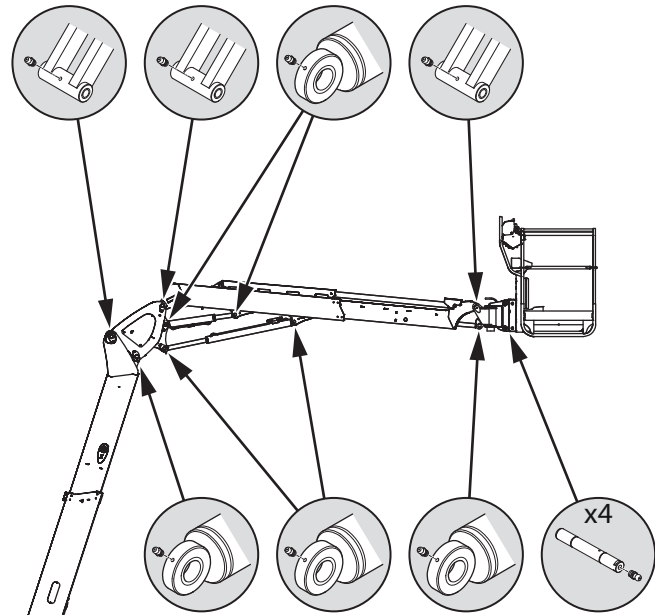

◀ 2 - DESCRIPTION: STICKERS:
REMOTE LUBRICATION.

NOTE: (A) and (B)

◀ LUBRICATE: RING GEAR.

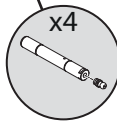
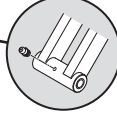
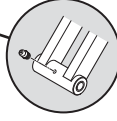
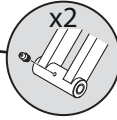
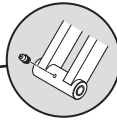
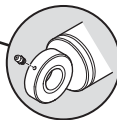
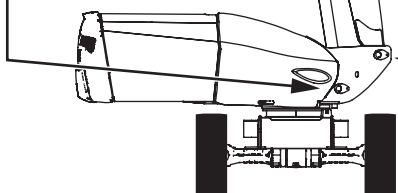
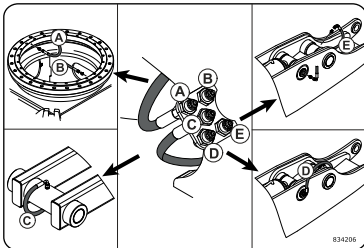

LUBRICATE

Telescope

⚠ IMPORTANT ⚠

Lubricate the telescope more often when the platform is operating in a dusty environment.

- Switch on the platform. Start the engine.
- Raise the jib slightly.
- Fully extend the telescope.

NOTE: Make sure that the basket does not hit the ground. Lift the jib again if necessary.

- Check the sliding surfaces **A** and **B** of the pads:
 - Surfaces must be smooth and free from corrosion.
- Lubricate the telescope if necessary, LUBRICANTS AND FUEL.

NOTE: Extend and retract the telescope several times to spread the lubricant. Remove the excess with a clean cloth.

- Fully retract the telescope.
- 260 TJ: Fully lower the jib.
- 260 TJ: Stop the engine. Power down the platform.

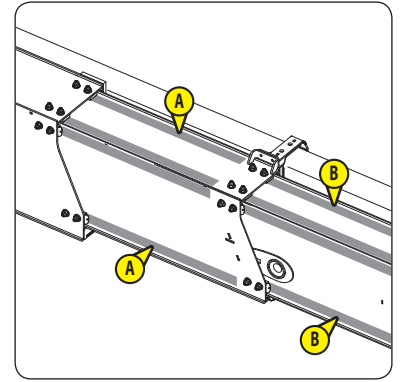

LUBRICATE

Jib telescope (only for 280 TJ)

⚠ IMPORTANT ⚠

Lubricate the jib telescope more often when the platform is operating in a dusty environment.

NOTE: The engine has been started. The jib is slightly raised.

- Fully extend the jib telescope.

NOTE: Make sure that the basket does not hit the ground. Lift the jib again if necessary.

- Check the sliding surfaces **A** of the pads:
 - Surfaces must be smooth and free from corrosion.
- Lubricate the jib telescope if necessary, LUBRICANTS AND FUEL.

NOTE: Extend and retract the jib telescope several times to spread the lubricant. Remove the excess with a clean cloth.

- Fully retract the jib telescope.
- Fully lower the jib.
- Stop the engine. Power down the platform.

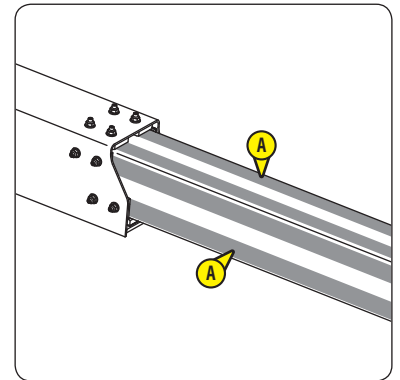

LUBRICATE

Crown gear

- Open the left-hand turntable cover.
- Inject the lubricant into the lubrication connectors, **A** and **B**. \triangleleft LUBRICANTS AND FUEL.

NOTE: \triangleleft 2 - DESCRIPTION: STICKERS: REMOTE LUBRICATION **C**.

- Switch on the platform. Start the engine.
- Turn the turntable 90° to the left or the right and inject lubricant again.
- Close the left-hand turntable cover.
- Lubricate the teeth of the crown gear **1**, \triangleleft LUBRICANTS AND FUEL.
- Turn the turntable a full turn to spread the lubricant.
- Place the turntable in the neutral position.
- Stop the engine. Power down the platform.

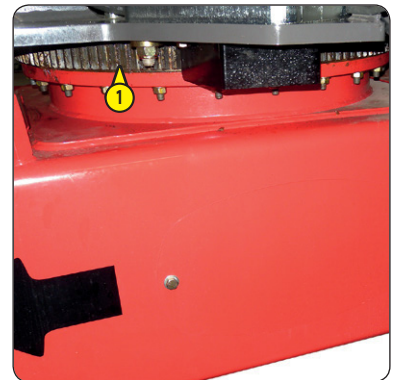
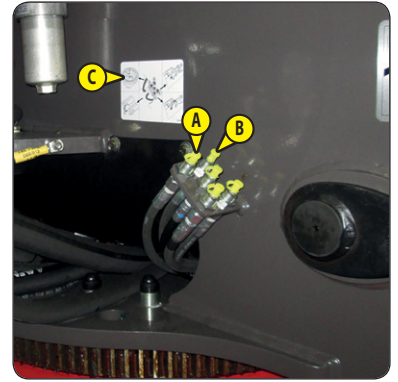

RESET

Maintenance warning

- \triangleleft 50H: RESET: MAINTENANCE WARNING.

CHECK

Jib telescope chocking (only for 280 TJ)

⚠ IMPORTANT ⚠

Not adhering to this instruction could damage the jib telescope.

It is recommended that the jib telescope chocking is adjusted if the clearances are higher than the maximum values,

⚠ REPAIR MANUAL.

- Switch on the platform. Start the engine.
- Raise the jib slightly.
- Check all the wheel nut tightening torques ①:
 - $69\text{ N} \pm 6.9\text{ N}$
- Extend the jib telescope for 1 second.
- Check the clearances between the pads and the jib telescope ②:
 - A (Upper pads ③) must be between 1 mm and 1.5 mm.
 - B (Side pads ④) must be between 0.5 mm and 0.75 mm on either side.
- Fully extend the jib telescope.

NOTE: Make sure that the basket does not hit the ground. Lift the jib again if necessary.

- Check the clearances A and B again.
- Fully retract the jib telescope.
- Take off the cover ⑤.
- Place several pallets under the basket.
- Slowly lower the jib until the pads ⑥ are in contact with the jib.
- Check the clearances between the pads and the jib:
 - C (Upper pads ⑦) must be between 1 mm and 1.5 mm.
 - D (Side pads ⑧) must be between 0.5 mm and 0.75 mm on either side.
- Raise the jib slightly.
- Remove the pallets.
- Fully lower the jib.
- Put the cover ⑤ back in place.

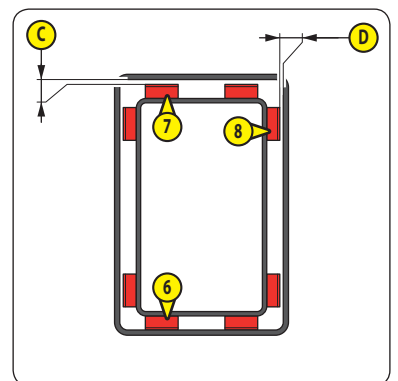
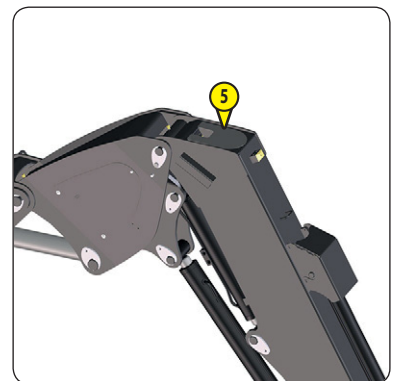
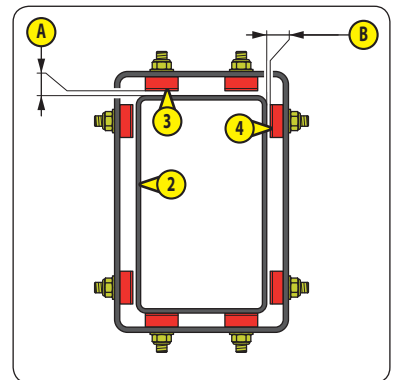
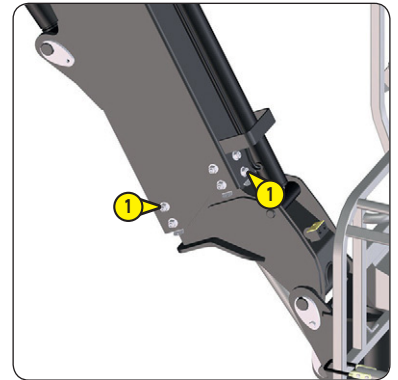

⚠ IMPORTANT ⚠

Not adhering to this instruction could damage the telescope.

It is recommended that the telescope wedging is adjusted if the clearances are higher than the maximum values,

⬅ REPAIR MANUAL.

NOTE: 280 TJ. The engine has been started.

- Check all the wheel nut tightening torques **1**:
 - 69 N ± 6.9 N
- 260 TJ: Switch on the platform. Start the engine.
- Raise the jib slightly.
- Extend the telescope for 1 second.
- Check the clearances between the pads and the intermediate telescope **2**:
 - **A** (Upper pads **3**) must be between 1 mm and 1.5 mm.
 - **B** (Side pads **4**) must be between 0.5 mm and 0.75 mm on either side.
- Check the clearances between the pads and the telescope **5**:
 - **C** (Upper pads **6**) must be between 1 mm and 1.5 mm.
 - **D** (Side pads **7**) must be between 0.5 mm and 0.75 mm on either side.
- Fully extend the telescope.

NOTE: Make sure that the basket does not hit the ground. Lift the jib again if necessary.

- Check the clearances **A**, **B**, **C** and **D** again.
- Fully retract the telescope.
- Take off the cover **8**.
- Raise the main jib slightly.
- Place several pallets under the basket.
- Slowly lower the main jib until the pads **9** are in contact with the upper jib, and the pads **10** are in contact with the intermediate jib **2**.
- Check the clearances between the pads and the main jib:
 - **E** (Upper pads **11**) must be between 1 mm and 1.5 mm.
 - **F** (Side pads **12**) must be between 0.5 mm and 0.75 mm on either side.
- Check the clearances between the pads and the intermediate telescope **2**:
 - **G** (Upper pads **13**) must be between 1 mm and 1.5 mm.
 - **H** (Side pads **14**) must be between 0.5 mm and 0.75 mm on either side.
- Raise the main jib slightly.
- Remove the pallets.
- Fully lower the main jib.
- Stop the engine. Power down the platform.
- Put the cover **8** back in place.

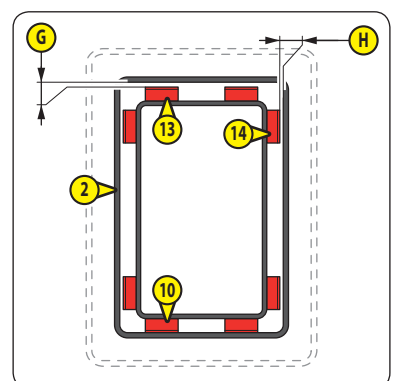
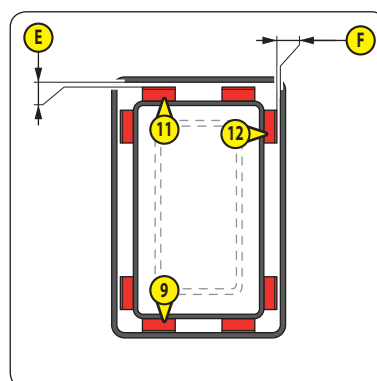
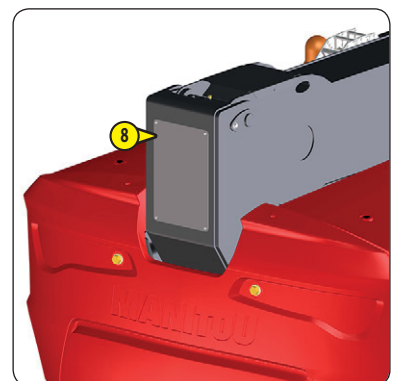
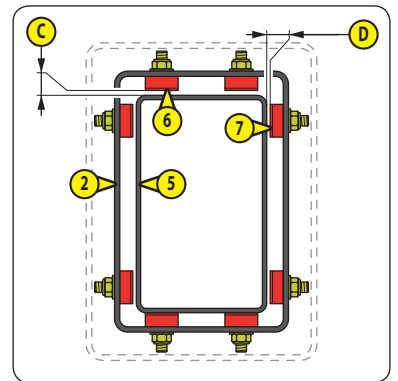
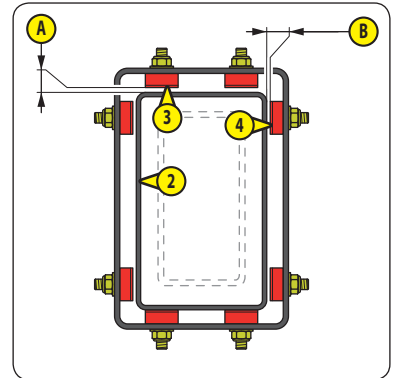
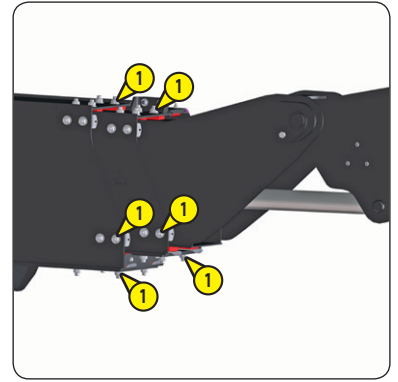

CHECK

Tightening of the fixing screws on the basket rotation cylinder

⚠ IMPORTANT ⚠

The tightening of the screws should be checked at the latest after the first 50 hours of service, then every 500 hours of service.

Not observing this instruction may cause failure of the fixing screws and damage to the basket rotation cylinder.

- Check all the fixing screw tightening torques ①:
 - 84 Nm ± 8 Nm

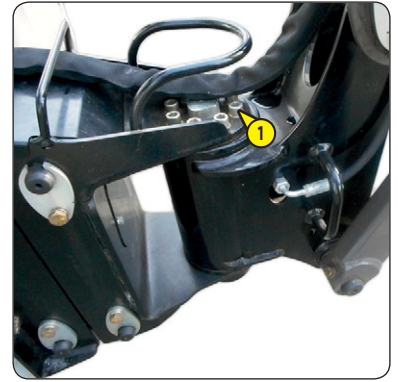

CHECK

Tightening of the fixing screws for the crown gear

⚠ IMPORTANT ⚠

The tightening of the screws should be checked at the latest after the first 50 hours of service, then every 500 hours of service.

Not observing this instruction may cause failure of the fixing screws and damage to the crown gear.

- Remove the right and left frame covers.
- Open the right-hand turntable cover.
- Locate the drill hole A.
- Open the left-hand turntable cover.
- Locate the drill hole B.
- Switch on the platform. Start the engine.
- Turn the turntable to align the drill holes A and B with 2 fixing screws ①.
- Check the tightening torque for the first 2 fixing screws ①:
 - 145 N ± 14 N
- Turn the turntable to align the drill holes A and B with the 2 following fixing screws ① to check their tightening torques.
- Repeat the steps until the tightening torque for each fixing screw ① has been checked.
- Check the tightening torque for the fixing screws ②:
 - 145 N ± 14 N
- Place the turntable in the neutral position.
- Stop the engine. Power down the platform.

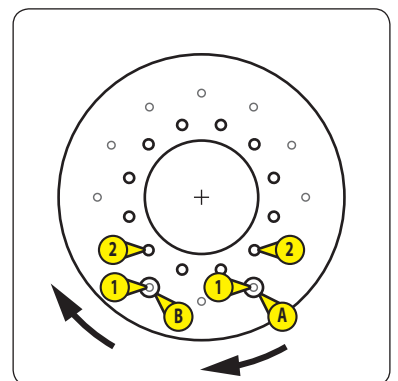

CHECK

Tightening of the fixing screws on the turntable rotation motor

⚠ IMPORTANT ⚠

Not observing this instruction may cause failure of the fixing screws and damage to the basket rotation motor and the crown gear.

- NOTE: The left and right turntable covers are open. The left and right frame covers have been removed.
- Check all the fixing screw tightening torques:
 - Screw ① = 208 Nm ± 20 Nm
 - Screw ② = 370 N ± 37 N

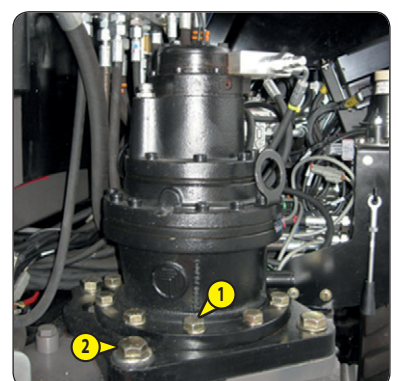

⚠ IMPORTANT ⚠

*Always use a piece of paper or cardboard to check there are no hydraulic oil leaks.
Replace any damaged hydraulic hoses.*

NOTE: The left and right turntable covers are open. The left and right frame covers have been removed.

- Open the swivelling engine plate, ⚠ OCCASIONAL OPERATION.
- Remove the front and rear frame covers.
- Check the condition of all the hydraulic hoses and that there are no leaks.
- Refit the front and rear frame covers.
- Refit the right and left frame covers.

REPLACE

Alternator/fan belt

NOTE: The right and left turntable covers are open. The swivelling engine plate is open.

- Replace the belt ①, ⚠ FILTERING ELEMENTS AND BELTS:
 - Loosen the screws ②.
 - Remove the used belt by swivelling the alternator.
 - Replace it with a new belt.
 - Tighten the screws ②.
- Check the belt tension between the crankshaft pulley and the alternator pulley:
 - Apply pressure with the thumb = 98 N. The clearance ③ must be between 7 mm and 9 mm to be correct.
- Adjust if necessary:
 - Loosen the screws ②.
 - Adjust the belt tension by swivelling the alternator.
 - Tighten the screws ②.
 - Check the belt tension again.

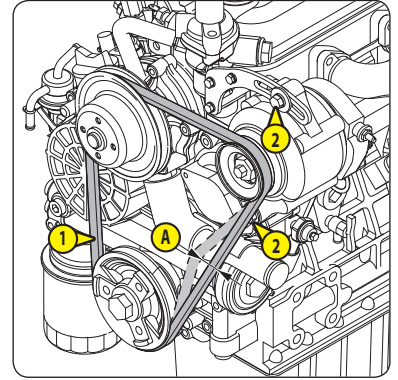

REPLACE

Fuel pre-filter

⚠ IMPORTANT ⚠

Never smoke or approach with a flame when the fuel pre-filter is being replaced.

NOTE: The right and left turntable covers are open. The swivelling engine plate is open.

- Locate the fuel pre-filter ① and put a drain container underneath.
- Replace the fuel pre-filter, ⚠ FILTERING ELEMENTS AND BELTS:
 - Remove the used fuel pre-filter.
 - Check the condition of the fuel hoses and the hose clamps.
 - Put the new fuel pre-filter in place. Make sure that the hose clamps are properly in place.

NOTE: Adhere to the fitting direction for the fuel pre-filter shown by an arrow.

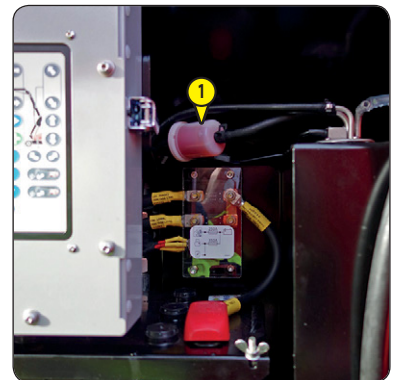

⚠ IMPORTANT ⚠

*Never smoke or approach with a flame when the fuel filter cartridge is being replaced.
 Never use the platform without the fuel filter cartridge or if it is damaged.*

NOTE: The right and left turntable covers are open. The swivelling engine plate is open.

- Clean the outside of the fuel filter ① with a clean cloth.
- Turn the tap ② to the position OFF.
- Replace the fuel filter cartridge ⑤, FILTERING ELEMENTS AND BELTS:
 - Unscrew the retaining ring ③.
 - Remove the tank ④ and the used fuel filter cartridge.
 - Clean the tank with clean fuel, LUBRICANTS AND FUEL.
 - Check its condition.
 - Refit the new fuel filter cartridge, tank and retaining ring.
- Check the condition of the fuel hoses and the hose clamps.
- Bleed the fuel supply circuit OCCASIONAL MAINTENANCE.

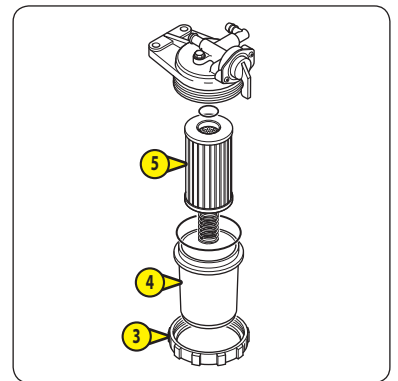
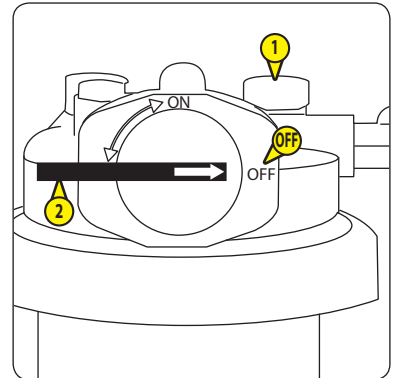
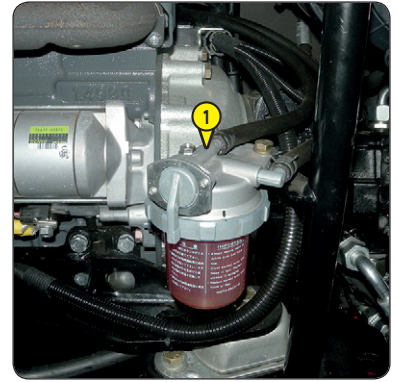

REPLACE

Engine oil

REPLACE

Engine oil filter

⚠ IMPORTANT ⚠

The replacement of the engine oil and the engine oil filter should be performed at the latest after the first 50 hours of service, then every 500 hours of service.

NOTE: The right and left turntable covers are open. The swivelling engine plate is open.

CHANGE THE OIL

- Switch on the platform. Start the engine.
- Allow it to run for 5 minutes.
- Stop the engine. Power down the platform.
- Locate the drain plug **1** and put a drain container underneath.
- Remove the drain plug and the filler plug **2**.
- Wait until the crankcase is completely drained.

REPLACE THE ENGINE OIL FILTER

- Place a drain tank under the engine oil filter **3**.
- Replace the engine oil filter, FILTERING ELEMENTS AND BELTS:
 - Unscrew the used engine oil filter.
 - Lubricate the seal of the new engine oil filter with clean engine oil, LUBRICANTS AND FUEL.
 - Screw up the new engine oil filter by hand and tighten it by a three-quarter turn using the oil filter spanner.

FILL THE ENGINE

- Clean around the drain hole with a clean cloth.
- Refit the drain plug.
- Fill the engine with new engine oil, LUBRICANTS AND FUEL.
- Wait for 5 minutes for the oil to settle in the crankcase.
- Refit the filler cap.
- Check the engine oil level, 10H: CHECK: ENGINE OIL LEVEL.
- Switch on the platform. Start the engine.
- Allow it to run for 5 minutes.
- Check for leaks.
- Stop the engine. Power down the platform.
- Wait for 5 minutes for the oil to settle in the crankcase.
- Check the engine oil level again and top up if necessary. 10H: CHECK: ENGINE OIL LEVEL.
- Close the swivelling engine plate, OCCASIONAL OPERATION.

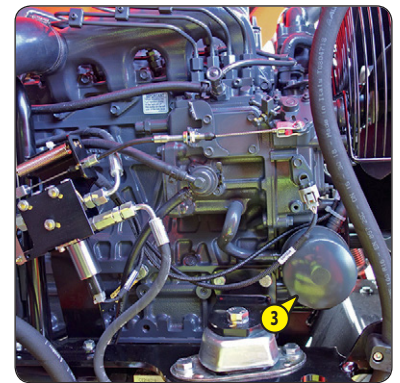
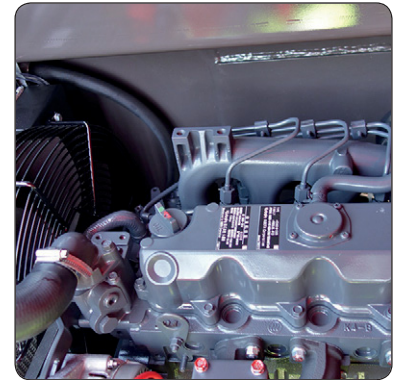

⚠ IMPORTANT ⚠

Never use the platform with a damaged air filter unit. Replace it if there is any doubt about its condition.

Never use the platform without the dry air filter cartridge or if it is damaged.

Never use the platform without the dry air filter safety cartridge or if it is damaged. If there is doubt about its condition, $\leq 1000\text{H}$: REPLACE: DRY AIR FILTER SAFETY CARTRIDGE.

If there is doubt about the condition of the air intake line, the air suction outlet hose and hose clamps, $\leq 1000\text{H}$: REPLACE: AIR INTAKE LINE AND AIR SUCTION OUTLET HOSE.

NOTE: The right and left turntable covers are open.

- Clean the outside of the air filter unit ① with a clean, slightly damp cloth.
- Unlock and remove the cover of the air filter unit ②.
- Clean the inside of the air filter unit cover with a clean, slightly damp cloth.
- Remove the valve ③ and clean it.
- Check the condition of the valve and replace it if it is damaged.
- Put the valve back in place.
- Remove the used dry air filter cartridge ④ pulling it gently to prevent dust dispersion.

NOTE: Do not press the centre of the dry air filter cartridge.

- Check the condition of the dry air filter safety cartridge ⑤ without taking it out.
- Check the condition of the air filter unit, the air intake line, the air suction outlet hose and the tightening clamps.
- Replace the dry air filter cartridge ④, $\leq 1000\text{H}$: FILTERING ELEMENTS AND BELTS:
 - Clean the seal of the new dry air filter cartridge with a clean cloth.
 - Put it in place pushing gently.

NOTE: Do not press the centre of the dry air filter cartridge.

- Refit the air filter unit cover ②, the valve ③ facing downwards, the marking "TOP" facing upwards.

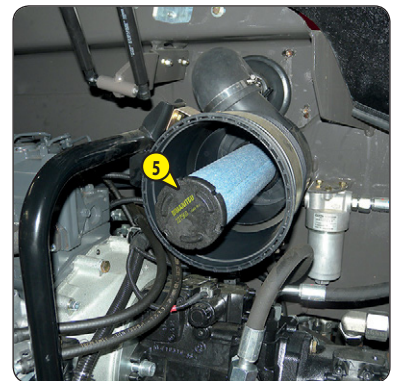
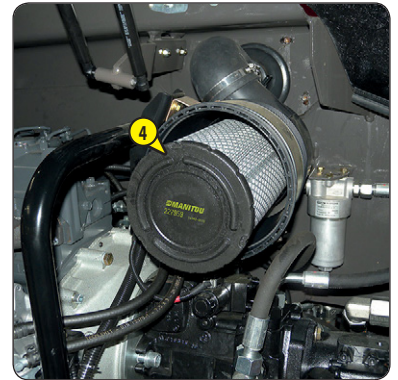
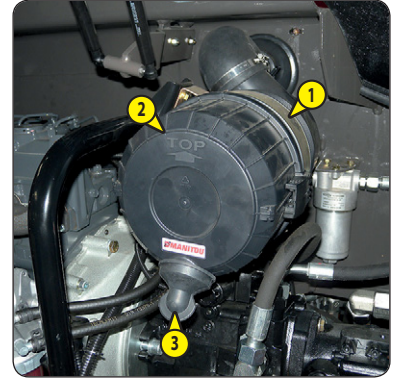

REPLACE

Turntable rotation motor oil

⚠ IMPORTANT ⚠

It is recommended that the oil is slightly warm before being changed.

NOTE: The right and left turntable covers are open.

CHANGE THE OIL

- Place a drain tank under the drain plug ①.
- Remove the drain plug and the filler plug ②.
- Wait until the crankcase is completely drained.

FILL THE TURNTABLE ROTATION MOTOR

- Clean around the drain hole with a clean cloth.
- Refit the drain plug.
- Fill the turntable rotation motor with new oil, ⚡ LUBRICANTS AND FUEL.
- Clean the gauge on the filler cap with a clean cloth and put it back in place.
- Remove the filler cap. The level is correct when the oil is between the 2 marks ④ and ⑤.
- If the level is low:
 - Add oil until the correct level is reached, ⚡ LUBRICANTS AND FUEL.
 - Refit the filler cap.
- If the level is correct:
 - Refit the filler cap.

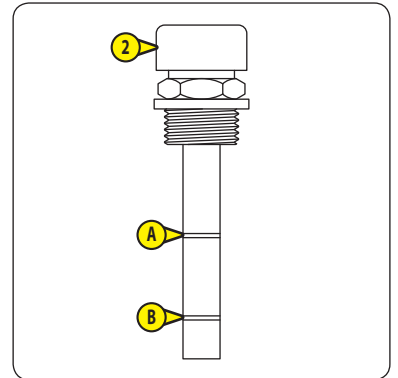
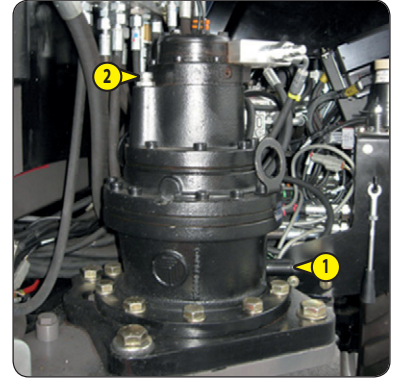

REPLACE

Hydraulic pressure filter cartridge

⚠ IMPORTANT ⚠

Never use the platform without the hydraulic pressure filter cartridge or if it is damaged.

NOTE: The right and left turntable covers are open.

Clean the outside of the hydraulic pressure filter ① with a clean cloth.

- Place a drain tank underneath.
- Replace the hydraulic pressure filter cartridge ②, ⚡ FILTERING ELEMENTS AND BELTS:
 - Unscrew the hydraulic pressure filter tank.
 - Remove the used hydraulic pressure filter cartridge.
 - Replace it with the new hydraulic pressure filter cartridge.
 - Put the hydraulic pressure filter tank back in place.
- Switch on the platform. Start the engine.
- Lift/lower the main boom, the secondary arm and the jib for several minutes.
- Fully lower the main boom, the main arm and the jib.
- Check for leaks.
- Close the right-hand turntable cover panel.
- Stop the engine. Power down the platform.

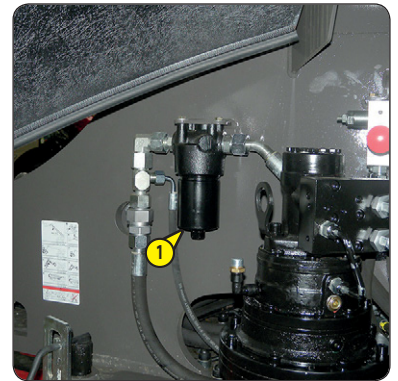

REPLACE

Hydrostatic transmission filter cartridge

⚠ IMPORTANT ⚠

Never use the platform without the hydrostatic transmission filter cartridge or if it is damaged.

NOTE: The left turntable cover is open.

Clean the outside of the hydrostatic transmission filter **1** with a clean cloth.

- Place a drain tank underneath.
- Replace the hydrostatic transmission filter cartridge **2**, \triangleleft FILTERING ELEMENTS AND BELTS:
 - Unscrew the hydrostatic transmission filter tank.
 - Remove the used hydrostatic transmission filter cartridge.
 - Replace it with the new hydrostatic transmission filter cartridge.
 - Put the hydrostatic transmission filter tank back in place.
- Close the left-hand turntable cover.
- Switch on the platform. Start the engine.
- Drive the platform forwards and backwards for several minutes.
- Open the left-hand turntable cover.
- Check for leaks.
- Check the hydraulic oil level, \triangleleft 10H: CHECK: HYDRAULIC OIL LEVEL.
- Close the left-hand turntable cover.
- Stop the engine. Power down the platform.

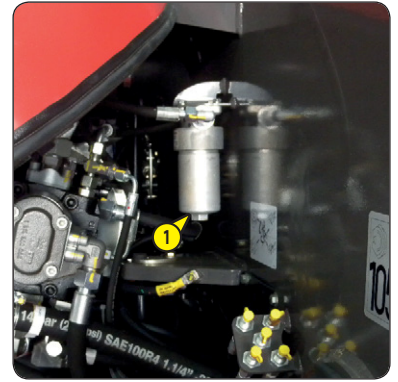

RESET

Maintenance warning

\triangleleft 50H: RESET: MAINTENANCE WARNING.

🔄 1000H - PERIODIC SERVICE - EVERY 1000 HOURS OF SERVICE OR 2 YEARS

ALSO PERFORM THE DAILY SERVICE AND THE PERIODIC SERVICES AT 250 HOURS AND 500 HOURS OF SERVICE.

CLEAN

Fuel tank

⚠️ IMPORTANT ⚠️

Never smoke or approach with a flame when the fuel tank is being cleaned.

- Open the right-hand turntable cover.
- Locate the drain plug **1** and put a drain container underneath.
- Open the flap **2**.
- Remove the drain plug and the tank plug **3**.
- Wait until the tank is completely drained.
- Rinse the tank with 10 litres of clean fuel, \leq LUBRICANTS AND FUEL.
- Clean around the drain hole with a clean cloth.
- Refit the drain plug.
- Fill the tank completely with clean fuel, \leq 10H: CHECK: FUEL LEVEL.
- Refit the tank cap and close the flap.
- Bleed the fuel supply circuit \leq OCCASIONAL MAINTENANCE.
- Close the right-hand turntable cover panel.

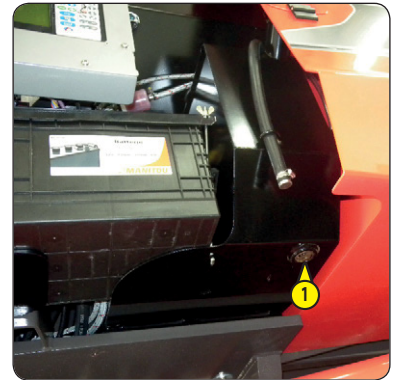

REPLACE

Dry air filter safety cartridge

⚠️ IMPORTANT ⚠️

Never use the platform without the dry air filter safety cartridge or if it is damaged.

- Open the left-hand turntable cover.
- Carry out the instructions described in 500H: REPLACE: Except DRY AIR FILTER CARTRIDGE:
- Replace the dry air filter safety cartridge **5**, \leq FILTERING ELEMENTS AND BELTS:
 - Remove the used dry air filter safety cartridge pulling it gently to prevent dust dispersion.
 - Block the outlet of the air filter unit with a clean cloth.
 - Clean the inside of the air filter unit with a clean, slightly damp cloth.
 - Remove the cloth from the air filter unit outlet.
 - Clean the seal of the new dry air filter safety cartridge with a clean cloth.
 - Put the new dry air filter safety cartridge in place by pushing it gently.

NOTE: Do not press the centre of the dry air filter safety cartridge.

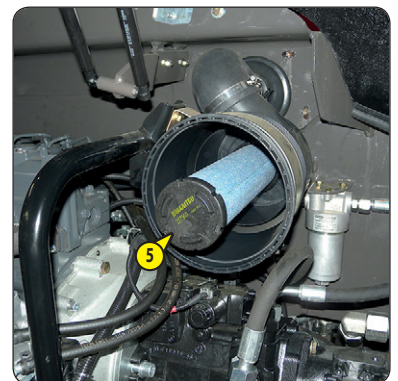

⚠ IMPORTANT ⚠

*Wait until the engine cools if it has been running for a while.
Do not remove the radiator cap until the engine is completely cooled.*

NOTE: The left turntable cover is open.

- Open the swivelling engine plate, ⚠ OCCASIONAL OPERATION.

DRAIN THE COOLANT

- Locate the drain plug **1** under the coolant radiator and put a drain container underneath.
- Remove the drain plug and the radiator cap **2**.
- Wait until the coolant has completely drained.

FILL THE COOLING CIRCUIT

- Clean around the drain hole with a clean cloth.
- Refit the drain plug.
- Fill the cooling circuit with new coolant, ⚠ LUBRICANTS AND FUEL. The level is correct when the coolant reaches the top of the filling hole.
- Refit the radiator cap.
- Switch on the platform. Start the engine.
- Allow it to run for 5 minutes.
- Check for leaks.
- Stop the engine. Power down the platform.
- Wait until the engine cools.
- Remove the radiator plug .
- Check the coolant level and top up if necessary.
- Refit the radiator cap.
- Close the swivelling engine plate, ⚠ OCCASIONAL OPERATION.
- Close the left-hand turntable cover.

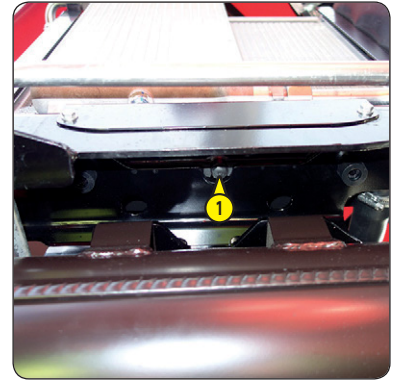

⚠ IMPORTANT ⚠

It is recommended that the oil is slightly warm before being changed.

CHANGE THE OIL

- Locate the reduction gearbox **1** on the rear axle.
- Clean the outside of the reduction gearbox with a clean cloth.
- Place a drain tank under the drain plug **2**.
- Remove the drain plug and the filler plug **3**.

NOTE: 2 filler caps (left and right sides).

- Wait until the reduction gearbox is completely drained.

FILL THE ENGINE REDUCTION GEARBOX

- Clean around the drain hole with a clean cloth.
- Refit the drain plug.
- Fill the reduction gearbox with new oil, ⚠ LUBRICANTS AND FUEL. The level is correct when the oil reaches the rim of the filling hole.
- Refit the filler cap.

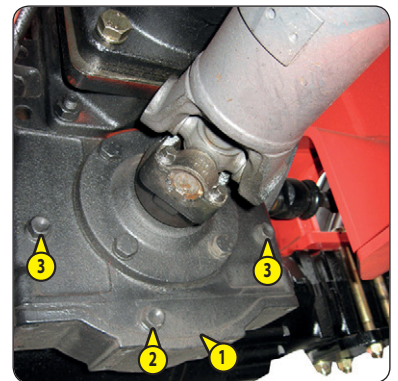

REPLACE

Front and rear axle differential oil

⚠ IMPORTANT ⚠

It is recommended that the oil is slightly warm before being changed.

NOTE: Check the oil in the axle differentials one by one.

CHANGE THE OIL

- Clean the outside of the axle differential with a clean cloth.
- Place a drain tank under the 3 drain plugs ①.
- Remove the 3 drain plugs and the filler plug ②.
- Wait until the axle differential is completely drained.

FILL THE AXLE DIFFERENTIAL

- Clean around the drain holes with a clean cloth.
- Refit the 3 drain plugs.
- Remove the level plug ③.
- Fill the axle differential with new oil, \triangleleft LUBRICANTS AND FUEL. The level is correct when the oil reaches the rim of the filling hole ③.
- Refit the level plugs and filler cap.

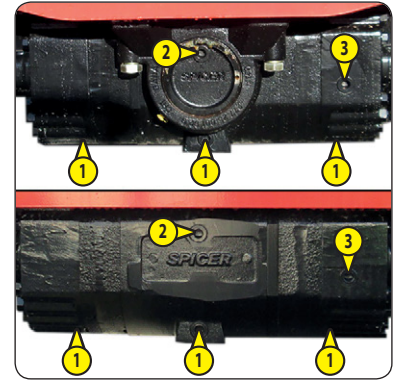

REPLACE

Front and rear wheel reduction gear oil

⚠ IMPORTANT ⚠

It is recommended that the oil is slightly warm before being changed.

NOTE: Check the oil in the wheel reduction gears one by one.

CHANGE THE OIL

- Clean the outside of the gear reducer with a clean cloth.
- Turn the wheel to put the drain/filler plug ① in position ①.
- Place a drain tank underneath.
- Remove the drain/filler plug.
- Wait until the wheel reduction gear has completely drained.

FILL THE WHEEL REDUCTION GEAR

- Clean around the drain/filler hole with a clean cloth.
- Turn the wheel to put the drain/filler plug ① in position ②.
- Fill the wheel reduction gear with new oil, \triangleleft LUBRICANTS AND FUEL. The level is correct when the oil reaches the rim of the filling hole.
- Refit the drain/filler plug:
 - Tightening torque = 42 Nm \pm 7 Nm

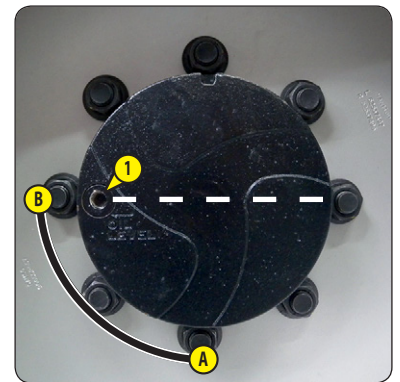

⚠ IMPORTANT ⚠

*It is recommended that the oil is slightly warm before being changed.
 There can be a difference in level of 10 mm to 20 mm between hot and cold oil. It is recommended the level is checked again when the hydraulic oil is hot.
 Clean the oil can before adding oil to the hydraulic oil tank.
 Use a clean funnel to add oil to the hydraulic oil tank.*

CHANGE THE OIL

- Open the right-hand turntable cover.
- Locate the drain plug ① and put a drain container underneath.
- Remove the drain plug and the tank plug ②.
- Wait until the tank is completely drained.

CLEAN THE FILLING FILTER AND SUCTION STRAINER

- Remove the filling filter ③.
- Clean it with compressed air, from the inside out:
 - Maximum pressure = 3 bars. Minimum distance = 30 mm.
- Check its condition and replace it if necessary, **FILTERING ELEMENTS AND BELTS.**
- Refit the filling filter.
- Remove the flap ④.
- Remove the suction strainer ⑤ located inside the tank.
- Clean the strainer with compressed air, from the inside out:
 - Maximum pressure = 3 bars. Minimum distance = 30 mm.
- Check its condition and replace it if necessary, **FILTERING ELEMENTS AND BELTS.**
- Refit the suction strainer and hatch.

FILL THE HYDRAULIC OIL TANK

- Refit the drain plug.
- Fill the tank with new hydraulic oil, **LUBRICANTS AND FUEL.** The level is correct when the oil reaches the red dot on the level indicator ⑥.
- Refit the tank cap.
- Switch on the platform. Start the engine.
- Use the platform controls for 10 minutes.
- Check for leaks.
- Put the platform in the transport position. Put the turntable and basket in the neutral position. Lower the jib completely.
- Check the hydraulic oil level. The level is correct when the oil reaches the red dot on the level indicator.
- Add hydraulic oil if necessary.
- Close the right-hand turntable cover panel.
- Stop the engine. Power down the platform.

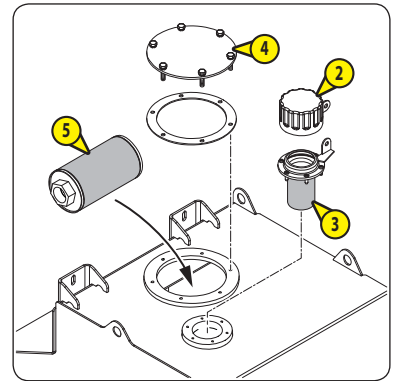
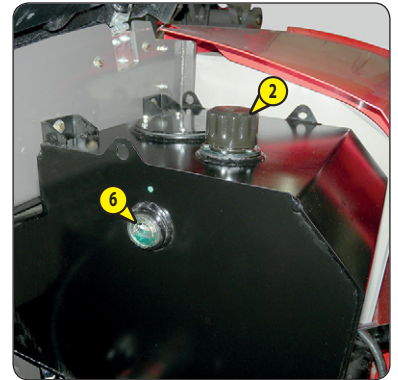

CHECK	Engine silent blocks *
CHECK	Engine speeds *
CHECK	Valve lash *
CHECK	Injectors *
CHECK	Hydrostatic transmission circuit pressure *
CHECK	Speeds of hydraulic movements *
CHECK	Condition of cylinders *
CHECK	Condition of electric wiring *
REPLACE	Air intake line and air suction hose *
REPLACE	Hoses and hose clamps for the coolant radiator *
REPLACE	Injection pipes, fuel hoses and the hose clamps *
RESET	Maintenance warning

⚠ 50H: RESET: MAINTENANCE WARNING.

*** Consult your dealer.**

➡ 4 2000H - PERIODIC SERVICE - EVERY 2000 HOURS OF SERVICE OR 4 YEARS

ALSO PERFORM THE DAILY SERVICE AND THE PERIODIC SERVICES AT 250 HOURS, 500 HOURS AND 1000 HOURS OF SERVICE.

CHECK	Coolant and oil radiators *
CHECK	Water pump and thermostat *
CHECK	Injection pump *
CHECK	Alternator and starter *
CHECK	Turbocharger *
CHECK	injection timing *
CHECK	Hydraulic circuit pressures *
CHECK	Hydraulic circuit flow rates *
CLEAN	Hydraulic oil tank *
RESET	Maintenance warning

⚠ 50H: RESET: MAINTENANCE WARNING.

* Consult your dealer.

REPLACE

Wheels

⚠ IMPORTANT ⚠

⚠ 2 - DESCRIPTION: CHARACTERISTICS and refer to the applicable stickers for information about the total weight of the platform and wheel load.

When lifting the platform with a mechanical or hydraulic jack:

- Always use a suitable jack for lifting the platform.
- Make sure that the 2 wheels on the opposite side to the lift are chocked.
- Position the jack near the wheel to be raised.
- Always use suitable jack stands to secure the raised platform.

⚠ IMPORTANT ⚠

Weight of a wheel = 290 kg

NOTE: We recommend the use of the hydraulic jack (MANITOU Part No. 505507) and the safety jack stand MANITOU Part No. 554772.

- Loosen the wheel nuts slightly.
- Raise the platform.
- Remove the wheel nuts and the wheel.
- Put the new wheel in place.
- Refit the wheel nuts and tighten them slightly with a spanner.
- Lower the platform to the ground.
- Tighten the wheel nuts, ⚠ 50H: CHECK: WHEEL NUT TIGHTENING.



⚠ IMPORTANT ⚠

Never smoke or approach with a flame when the fuel supply circuit is being bled.

Always bleed the fuel supply circuit when:

- *The fuel tank has been drained and then filled.*
- *There has been a fuel breakdown and then the fuel tank has been filled.*
- *A component of the fuel supply circuit has been cleaned or replaced.*

If the engine runs irregularly or stops after bleeding the fuel supply circuit, check the condition of the entire fuel supply circuit.

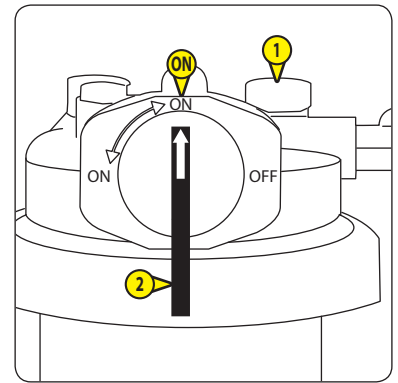
**BLEED THE FUEL FILTER**

- Open the left-hand turntable cover.
- Open the swivelling engine plate, ⚠ OCCASIONAL OPERATION.
- Place a drain tank under the fuel filter ①.
- Turn the tap ② to the position ON.
- Unscrew the bleeder screw ③.
- Locate the fuel pump ④.
- Action the manual pump ⑤ until fuel runs out of the bleeder screw.
- Continue pumping and tighten the bleeder screw.

BLEED THE INJECTION PUMP

- Locate the bleeder screw ⑥ and put a drain container underneath.
- Unscrew bleeder screw.
- Action the manual pump ⑤ until fuel runs out of the bleeder screw.
- Continue pumping and tighten the bleeder screw.
- Switch on the platform. Start the engine.
- Allow it to run for 5 minutes.
- Check for leaks.
- Stop the engine. Power down the platform.
- Close the swivelling engine plate, ⚠ OCCASIONAL OPERATION.
- Close the left-hand turntable cover.

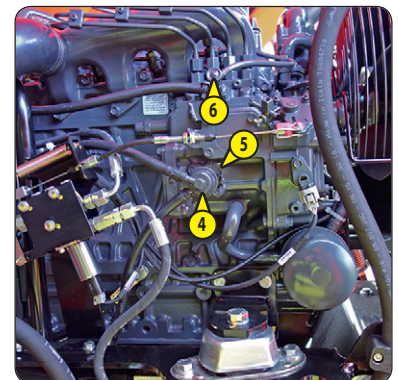
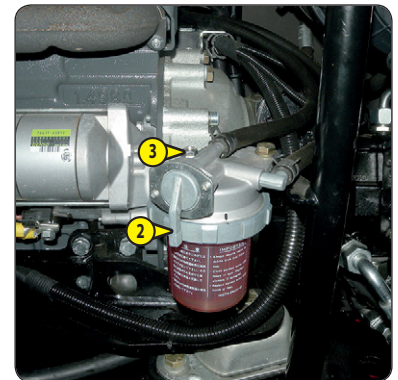

MAIN FUSE BOX

- Open the right-hand turntable cover.
- Locate the main fuse box ①.
- Remove the cover of the box.
- Replace the appropriate fuse:

Ⓐ	Backup pump	250 A fuse
Ⓑ	General power supply - up to machine no. 964802	250 A fuse
Ⓑ	General power supply - from machine no. 964803	350 A fuse

- Put the box cover back in place.
- Close the right-hand turntable cover panel.

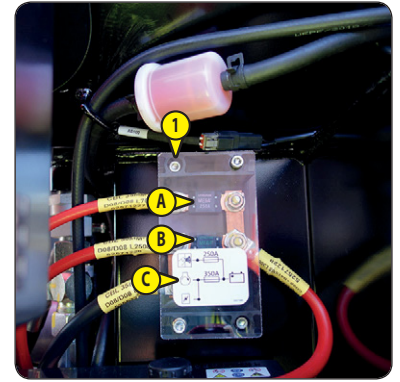

ECU FUSES/RELAYS BRC 20 AND BRC 30

- Open the right-hand turntable cover.
- Locate the ECU BRC 20 ② and BRC 30 ③.
- Unlock and remove the cover of the appropriate ECU.
- Replace the appropriate fuse.
- Refit the ECU cover.
- Close the right-hand turntable cover panel.

BRC 20:

Ⓕ	ECU power supply (+BAT) UPC 20	25 A fuse
Ⓖ	ECU power supply (+BAT) UPC 20	25 A fuse
Ⓕ	ECU power supply (+BAT) BRC 20	25 A fuse
Ⓖ	ECU power supply (+BAT) BRC 20	25 A fuse
Ⓕ	ECU power supply (+BAT) UPC 20 and interface screen CEK 20	5 A fuse
Ⓖ	Working light power supply (OPTION)	10 A fuse

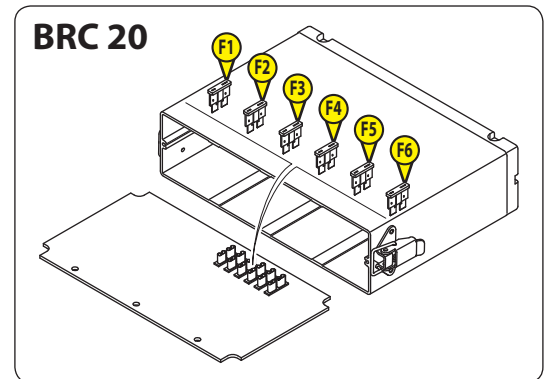
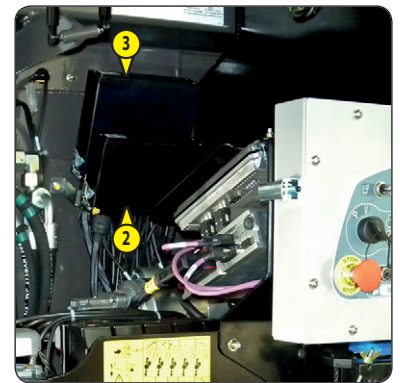

BRC 30:

F1	Engine starter button	5 A fuse
F2	ECU power supply (+BAT) UPC 30	30 A fuse
F3	ECU power supply (+BAT) UPC 30	30 A fuse
F4	Backup pump power supply	10 A fuse
F5	ECU power supply (+BAT) UPC 110	5 A fuse
F6	Ignition switch	10 A fuse
F7	Engine starter power supply	30 A fuse
F8	Engine preheat power supply	30 A fuse
F9	Engine preheat power supply	30 A fuse
F10	ECU power supply (+BAT) UPC 110	5 A fuse
F11	ECU power supply (+BAT) UPC 30	10 A fuse
F12	ECU power supply (+BAT) BRC 30	30 A fuse
F13	ECU power supply (+BAT) BRC 30	30 A fuse
F14	ECU power supply (+BAT) UPC 110	5 A fuse
K1	Overload safety	12 V relay
K3	Engine starter	12 V relay
K4	Engine immobiliser system (OPTION)	12 V relay
K5	Emergency stop	12 V relay
K6	Emergency stop	12 V relay
K7	Engine shut-down	12 V relay
K8	Engine preheat	12 V relay
K9	Engine preheat	12 V relay

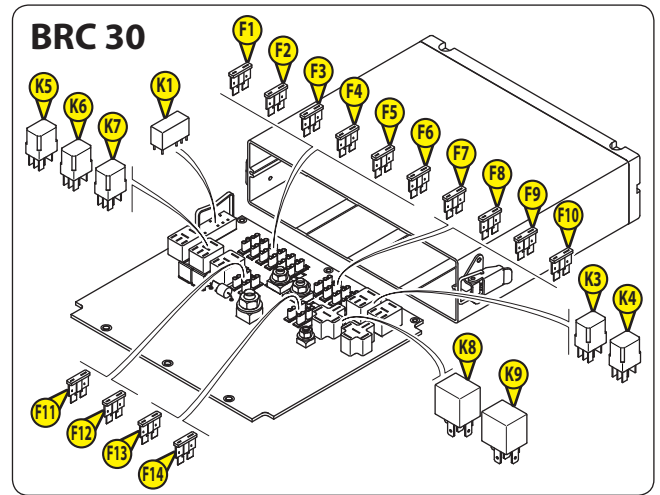

USE

Swivelling engine plate

⚠ IMPORTANT ⚠

- Always use the handle **A** to manipulate the swivelling engine plate.
- Ensure the safety slide is in position **III** (swivelling engine plate locked) before working on the platform.

OPEN THE SWIVELLING ENGINE PLATE

- Open the left-hand turntable cover.
- Remove the screw, nut and washer **1**.
- Pull the handle **A** to pivot the engine plate.
- Locate the safety slide **B**.
- Ensure that the safety slide is correctly locked, refer to steps **I**, **II** and **III** in the illustration.

CLOSE THE SWIVELLING ENGINE PLATE

- Unlock the safety slide **B** in the reverse order of the procedure for locking it.
- Push on the handle **A** to refit the swivelling engine plate.
- Refit the screw, nut and washer **1**.
- Close the left-hand turntable cover.

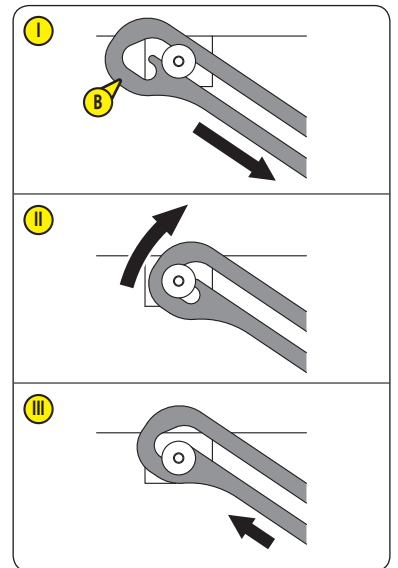
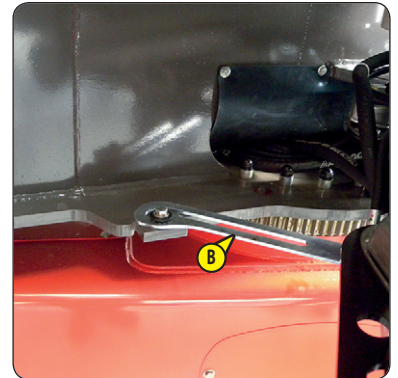
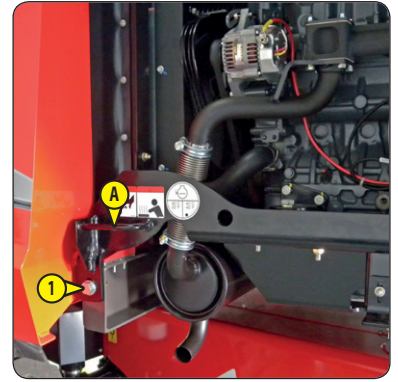

⚠ IMPORTANT ⚠

Before putting the platform into freewheel:

- *The platform must be on a level surface.*
- *The wheels must be chocked.*

The basket must be empty when the platform is being winched.

FREEWHEEL AND WINCH

- Attach the winch to the platform's lashing points,
 - ↳ 2 - DESCRIPTION: STICKERS: LASHING POINTS.
- Bypass the hydrostatic circuit:
 - Open the left-hand turntable cover.
 - Locate the hydrostatic pump and the 2 pressure relief valves **1**.
 - Loosen the nuts **1A**. Tighten the screws **1B** to the hard spot and then tighten them a half turn more.
 - Tighten the nuts **1A**: Tightening torque 22 Nm.
 - Close the left-hand turntable cover.
- Loosen the rear axle brakes:
 - Locate the 2 screws **3** and the 2 screws **4** to the left and right of the rear axle.
 - Loosen the 2 locknuts **2** by about 8 mm.
 - Tighten the screws **3** and **4** by hand to the hard spot.
 - Tighten the 2 screws alternately **3** by a quarter turn each time until you have gone all the way round.
 - Tighten the 2 screws alternately **4** by a quarter turn each time until you have gone all the way round.
- Disengage front axle brakes:
 - Do the same as for the rear axle.
- Make sure the route is free of any obstruction.
- Remove the chocks from the wheels.
- Winch the platform slowly.
- Chock the wheels when the platform is in the desired position.

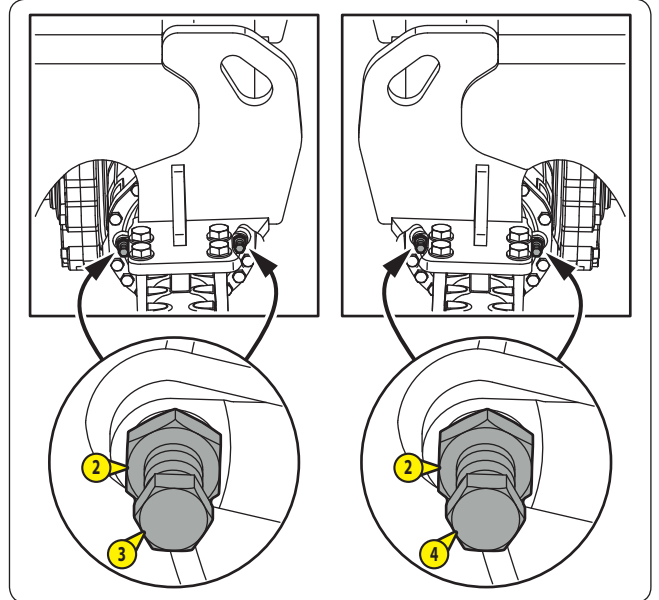
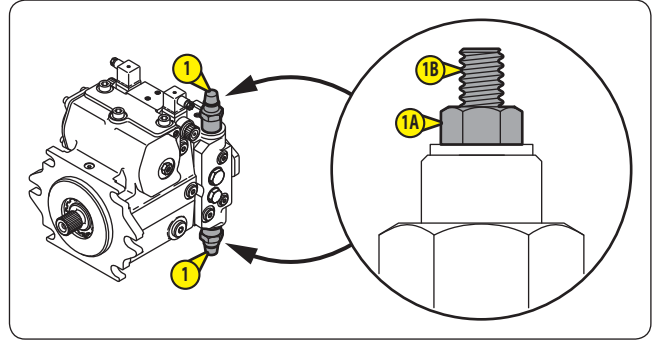

PUT THE BRAKES BACK INTO ACTION

- Put the rear axle brakes back into action:
 - Loosen the 2 screws alternately **3** by a quarter turn each time until you have gone all the way round.
 - Loosen the 2 screws alternately **4** by a quarter turn each time until you have gone all the way round.
 - Unscrew the 4 screws **3** and **4** completely.
 - Change the 4 seals **5**.
 - Lubricate the screws **3** and **4** with MANITOU BLACK MULTI-PURPOSE LUBRICANT (↖ LUBRICANTS AND FUEL) and put them back in place.
 - Adjust the distance between the body of the axles and the screw heads = 34 mm ±0.5 mm.
 - Tighten the 4 locknuts **2** and check the distances between the body of the axle and the screw heads.
- Put the front axle brakes back into action:
 - Do the same as for the rear axle.
- Put the hydrostatic circuit back into action:
 - Open the left-hand turntable cover.
 - Unscrew the nuts **1A**. Loosen the screws **1B** up to the mechanical stop.
 - Tighten the nuts **1A**: Tightening torque 22 Nm.
 - Close the left-hand turntable cover.
- Detach the winch and remove the wheel chocks.
- Test the brakes:
 - Remove the right-hand frame cover **6** to access the brake unit **7**.
 - Disconnect the coil EV100 of the brake unit (↖ 2 - DESCRIPTION: STICKERS: BRAKE UNIT COIL).
 - Start the engine and try to drive the platform forwards and backwards.

Result: The platform should remain stationary.
- Reconnect the EV100 coil of the brake unit **7**.
- Refit the right-hand frame cover **6**.
- Stop the engine. Power down the platform.

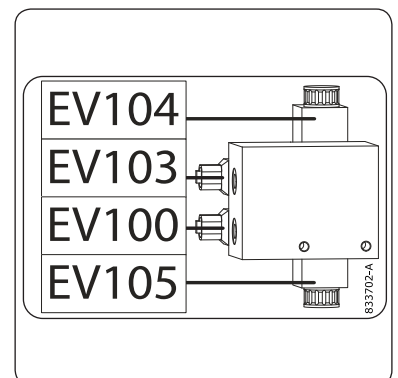
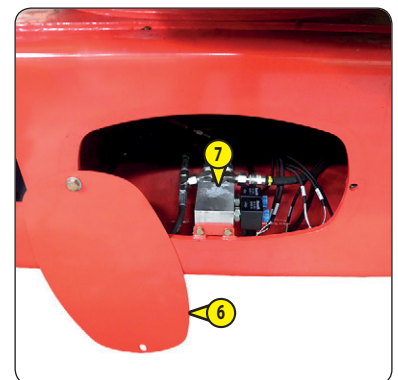
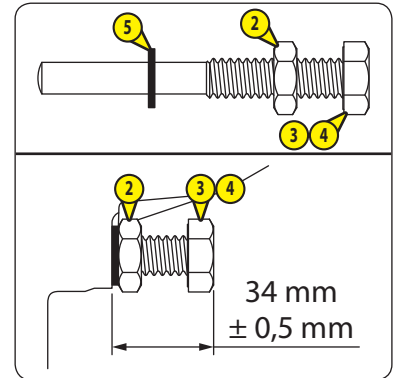
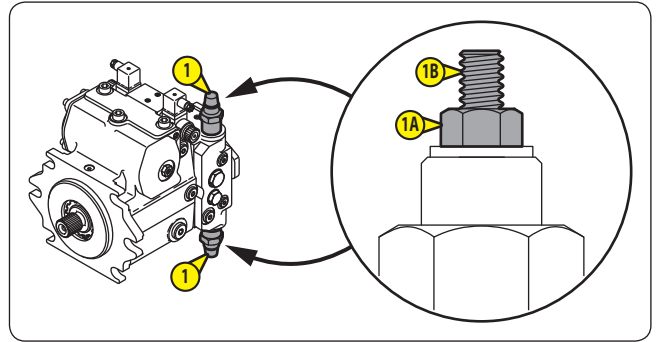

TRANSPORT

Platform

- ↖ 2 - DESCRIPTION: TRANSPORT OF THE PLATFORM.

4 - ACCESSORIES

4 - ACCESSORIES

INTRODUCTION		4-2
PIPE SUPPORT	Part no. 52571261OPT	4-4
PANEL SUPPORT	Part No. 52571261OPT	4-8

INTRODUCTION

⚠ IMPORTANT ⚠

The accessories, PIPE SUPPORT and PANEL SUPPORT cannot be installed at the same time on the same platform:

- It is essential to remove the PANEL SUPPORT if the PIPE SUPPORT is installed.*
- It is essential to remove the PIPE SUPPORT if the PANEL SUPPORT is installed.*

INSTALLATION

⚠ IMPORTANT ⚠

*It is essential to replace the nuts 5 each time an accessorie is installed.
 Inspect all the other accessorie components before each new installation and replace them if necessary.
 Clean the stickers to make them legible. It is essential to replace stickers which are illegible or damaged.
 Check that the stickers are present after replacing any spare parts.
 The supports 1 must be fitted inside the basket and must be resting on the floor of the basket.
 The supports 1 must be fitted symmetrically on each side of the basket and must be perpendicular to the basket floor.*

- Place the machine in the transport position.
- Place the basket in the down position.
- Switch off the machine by turning the ignition key to position .
- Place the first cradle 1 in the basket between the two pipes A1 and B1.

NOTE: position the safety sticker facing outwards.

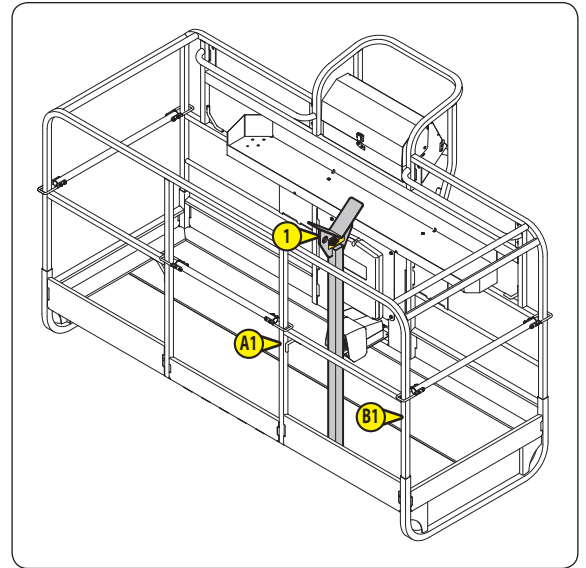

- Screw the first cradle 1 to the basket using two flanges 2 and the fasteners 3 to 5. Hand-tighten the nuts 5.

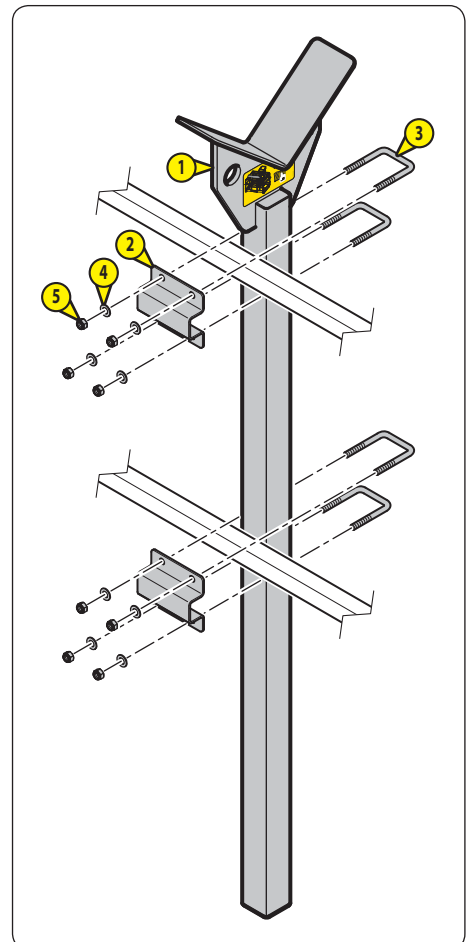

- Place the second cradle 1 in the basket between the two pipes A2 and B2 and screw it to the basket like the first cradle.

NOTE: position the safety sticker facing outwards.

- Adjust the distance between the two cradles 1.
- Tighten the nuts 5 crosswise:
 - Two threads of the callipers 3 must be visible.

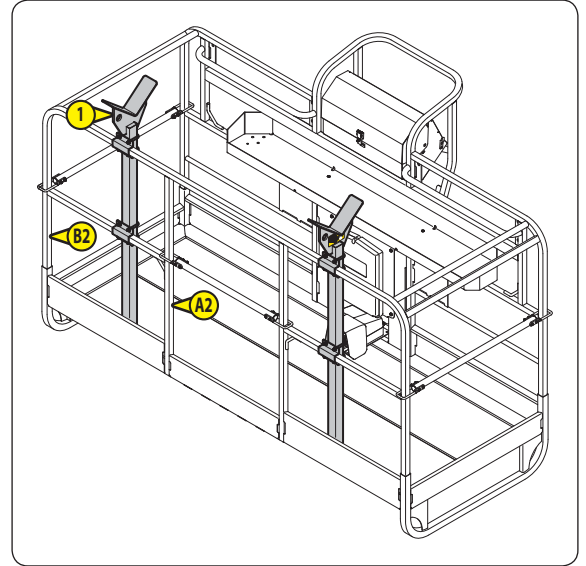

DISMANTLING

⚠ IMPORTANT ⚠

It is essential the nuts 5 are replaced for each new accessorie installation. It is recommended that they are discarded after each dismantling and replaced for the next installation.

*It is recommended that all the other components are inspected after each dismantling of the accessorie and replaced if necessary.
Store the accessorie in a clean, dry place.*

⚠ IMPORTANT ⚠

*Check that the pipe support is correctly adjusted, **⚠ ADJUSTMENT**.
 The machine and the basket should be level before fitting the pipe(s) on the pipe support.
 The length of the pipe(s) should not be greater than the width of the basket.
 The pipe(s) should be centred with the basket.*

- Place the machine in the transport position on level ground.
- Level the basket and place it in the down position.
- If necessary, adjust the distance between the cradles, **⚠ ADJUSTMENT**.
- Place one or more pipes on the pipe support.
- Attach the pipe(s) to the cradles using straps (not supplied).

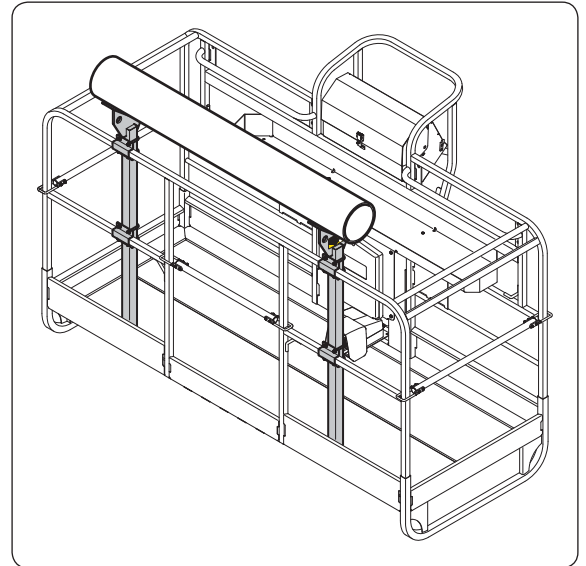

⚠ IMPORTANT ⚠

The weight of the pipe support and the pipe(s) reduces the basket's load capacity.

BASKET LOAD CAPACITY SPECIFICATIONS		260 TJ			280 TJ				
		1	2	3	ZONE A*			ZONE B*	
1	2				3	1	2		
Number of people in the basket									
Load capacity in the basket	kg (lbs)	255 (562)	175 (385)	95 (209)	205 (451)	125 (275)	45 (99)	95 (209)	15 (33)
Maximum permissible weight on the pipe support	kg (lbs)	50 (110)							

*: **⚠ 2 - DIMENSIONS AND DIAGRAM 280 TJ** for the definition of zones.

ADJUSTMENT

⚠ IMPORTANT ⚠

*The supports must be resting on the floor of the basket.
The supports must be fitted symmetrically on each side of the basket and must be perpendicular to the basket floor.*

- Loosen the nuts 2.
- Adjust the width between the cradles 1.
- Retighten the nuts 5 crosswise:
 - Two threads of the callipers 3 must be visible.

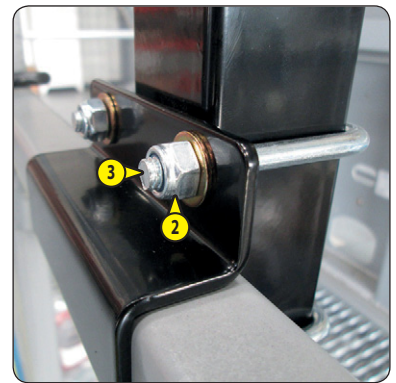
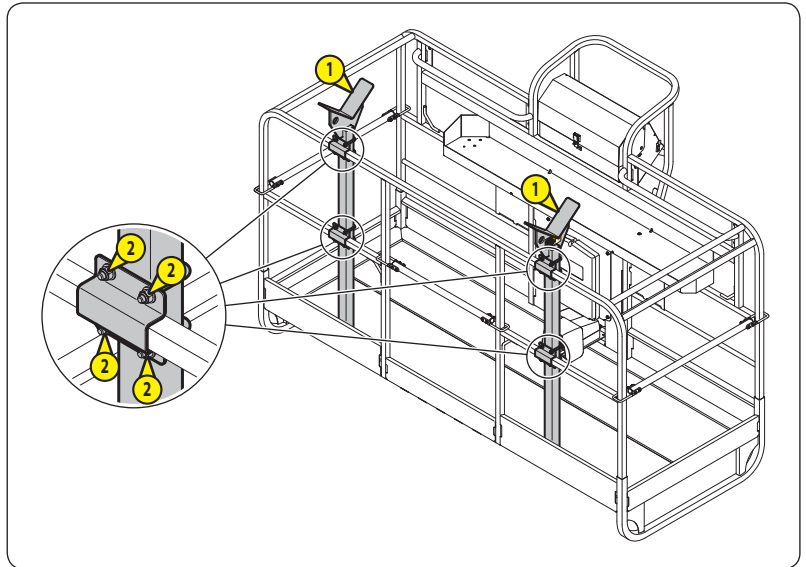

PIPE SUPPORT STICKER

Part No. 52557917

Indicates the maximum permissible weight on the pipe support.

Quantity = 2: one sticker on each support.

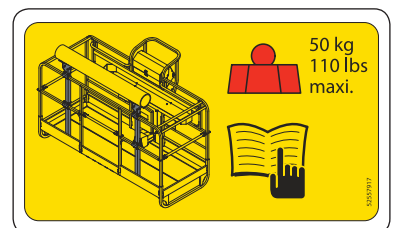

INSTALLATION

⚠ IMPORTANT ⚠

*It is essential to replace the nuts 6 and 13 each time an accessorie is installed.
 Inspect all the other accessorie components before each new installation and replace them if necessary.
 Clean the stickers to make them legible. It is essential to replace stickers which are illegible or damaged.
 Check that the stickers are present after replacing any spare parts.*

- Place the machine in the transport position.
- Place the basket floor about 1.2 m (4 ft) from the ground.
- Switch off the machine by turning the ignition key to position .
- Position the cradles 1 on the base boards on either side of the basket.

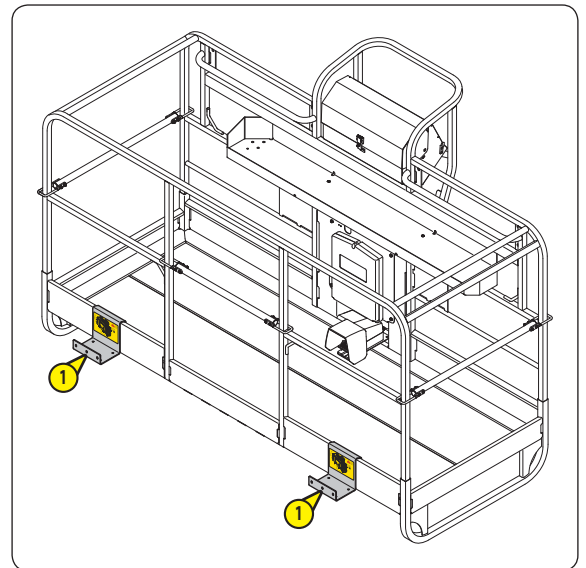

- Screw the cradles 1, the flanges 2 and the horizontal pads 3 using the screws 4, 5 and 6:
 - The screw heads 4 must penetrate approximately 2 mm into the horizontal pads (3).
 - Two threads of the screws (4) must be visible.

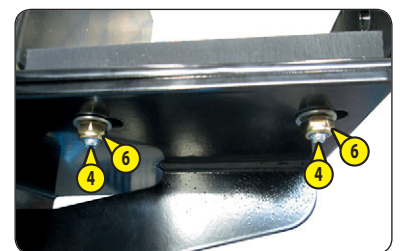
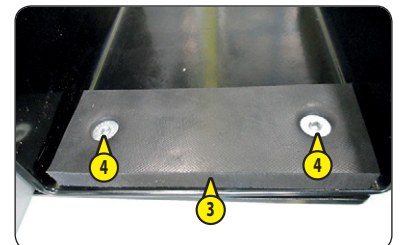
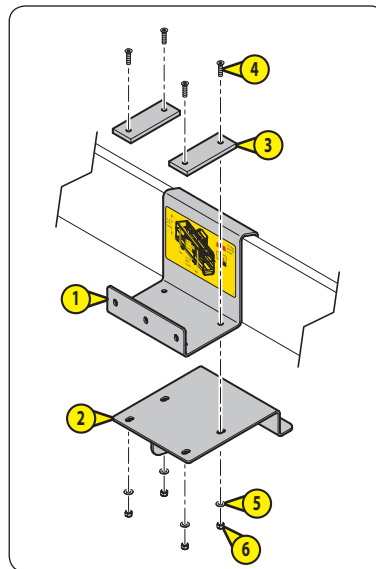

- Mount the vertical pads 7 using the screws 8, 9 and 10:
 - Tightening torque = $8.2 \text{ N.m} \pm 1.6 \text{ N.m}$

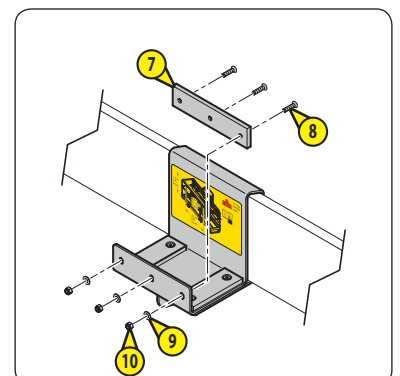

⚠ IMPORTANT ⚠

Only configurations I and II are authorised

- Choose one of the two configurations:

CONFIGURATION		I	II
Minimum panel width	m (ft)	1.2 (4)	2.2 (6.5)
Maximum panel width	m (ft)	2.5 (8)	
Maximum panel height	m (ft)	1.2 (4)	

- Remove the screws A or B (screw 11, washers 12 and nuts 13) depending on the configuration chosen.
- Scrap the nuts 13.
- Move and screw the cradles using the screws A or B with new nuts 13:
 - Tightening torque = 20 N.m ± 4 N.m

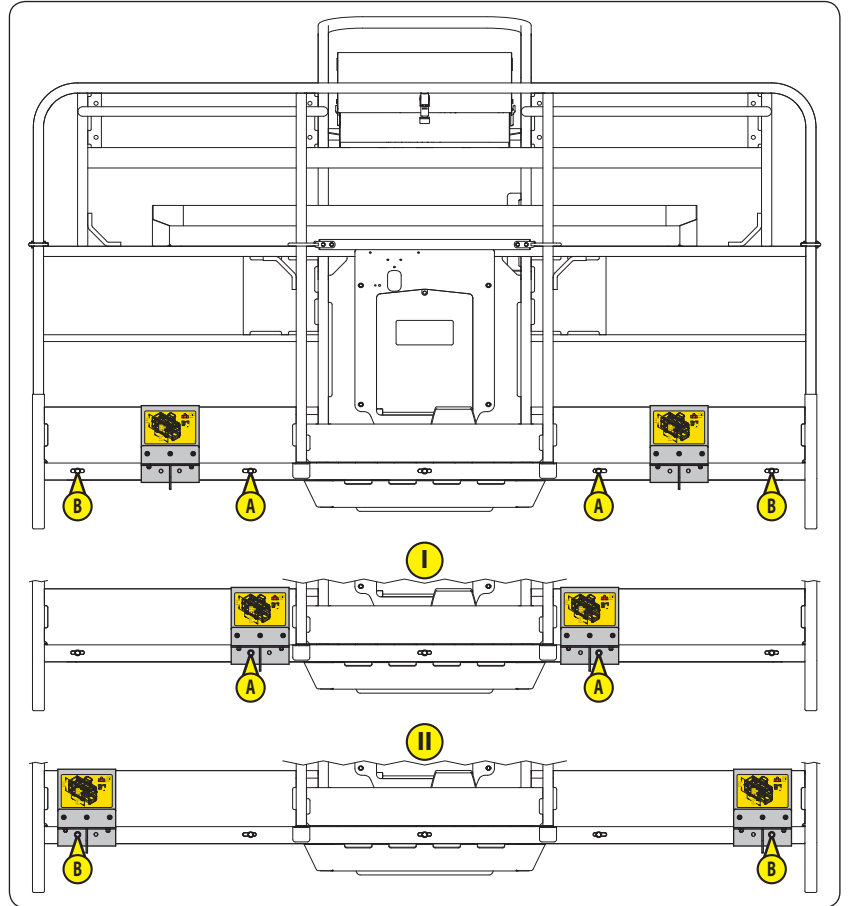
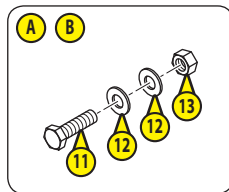

- Install the foam profiles 14 and the sleeves 15.
- Install strap 16 between the two pipes C1 and D1 and between the two pipes C2 and D2 of the basket.

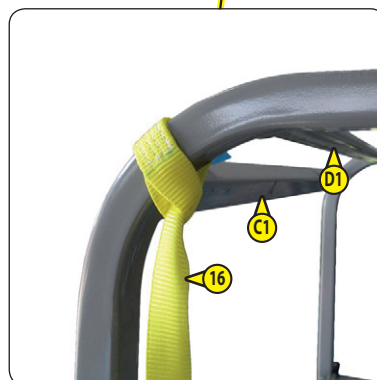
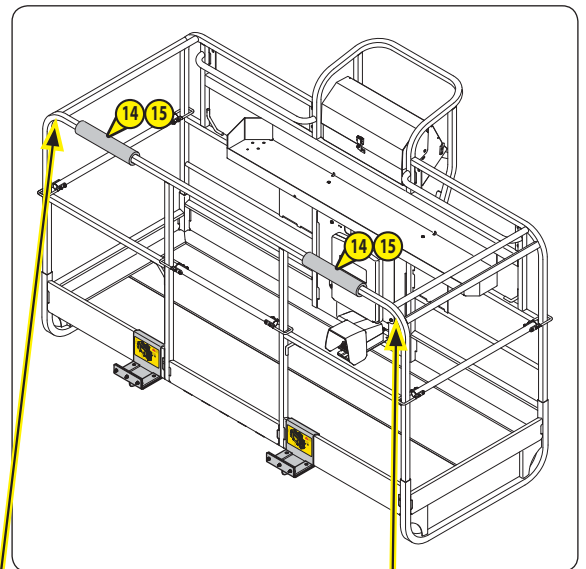

⚠ IMPORTANT ⚠

It is essential the nuts 6 are replaced for each new accessorie installation. It is recommended that they are discarded after each dismantling and replaced for the next installation.

*It is recommended that all the other components are inspected after each dismantling of the accessorie and replaced if necessary.
Store the accessorie in a clean, dry place.*

- Remove the panel support.
- Scrap the nuts 13.
- Replace the screws A or B with new nuts 13:
 - Tightening torque = $20 \text{ N.m} \pm 4 \text{ N.m}$

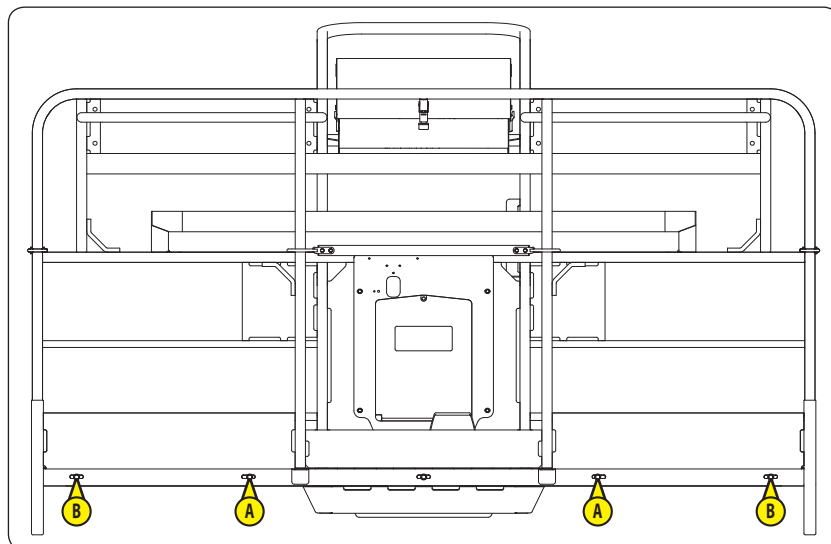
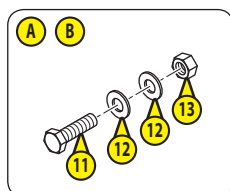

⚠ IMPORTANT ⚠

*The machine and the basket should be level before fitting the panel(s) on the panel support.
The panel(s) should be centred with the basket.*

- Place the machine in the transport position on level ground.
- If required, adjust the basket height.
- Level the basket.
- Place one or more panels on the panel support.
- Attach the panel(s) to the basket using the strap.

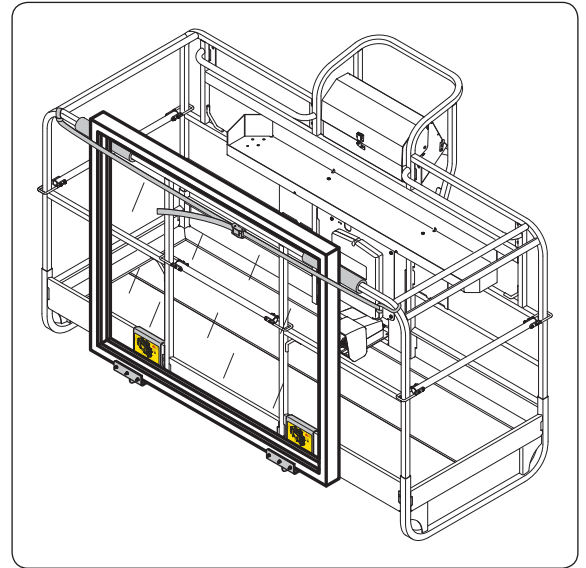

⚠ IMPORTANT ⚠

The weight of the panel support and the panel(s) reduces the basket's load capacity.

BASKET LOAD CAPACITY SPECIFICATIONS	260 TJ			280 TJ					
	1	2	3	ZONE A*			ZONE B*		
				1	2	3	1	2	
Number of people in the basket	1	2	3	1	2	3	1	2	
Load capacity in the basket	192 (423)	112 (246)	32 (70)	142 (313)	62 (136)	0 (0)	32 (70)	0 (0)	
Maximum permissible weight on the panel support	113 (250)			113 (250)	95 (209)	113 (250)	65 (143)		

*: 2 - DIMENSIONS AND DIAGRAM 280 TJ for the definition of zones.

⚠ IMPORTANT ⚠

Only configurations I and II are authorised, \neq INSTALLATION to modify the configuration.

CONFIGURATION		I	II
Minimum panel width	m (ft)	1.2 (4)	2.2 (6.5)
Maximum panel width	m (ft)	2.5 (8)	
Maximum panel height	m (ft)	1.2 (4)	

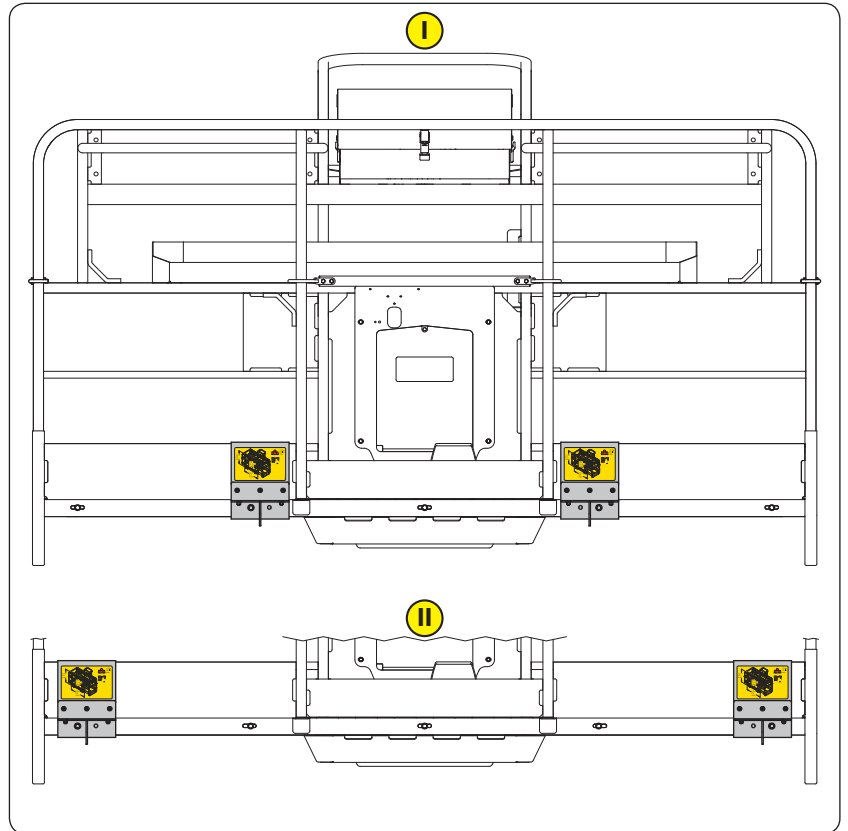

PIPE SUPPORT STICKER

Part No. 52557917

Indicates the maximum permissible weight on the panel support and the maximum dimensions of the panel(s).

Quantity = 2: one sticker on each support.

